



LONGITUDE
ONE TWENTY°
ENGINEERING & DESIGN

Structural Package for:
Granbois Residence

8440 SE 82nd St
Mercer Island, WA 98052

Project No: S230110-1

August 23, 2024



STRUCTURAL ENGINEER
L120 ENGINEERING & DESIGN
13150 91ST PL NE
KIRKLAND, WA 98034
CONTACT: MANS THURFJELL, PE
PHONE: 425-636-3313
MTHURFJELL@L120ENGINEERING.COM

 (425) 636 3313

 L120Engineering.com



LONGITUDE
ONE TWENTY°
ENGINEERING & DESIGN

Design Criteria

Project Number: S230110-1	Plan Name: Granbois	Sheet Number: DC
Engineer: HK	Specifics: Design Criteria	Date: 8/22/2024

Gravity Criteria:

Code: IBC 2021

ROOF SYSTEM			
Live Load:			
Snow	25.0	psf	
Dead Load:			
Composite Roofing	2.0	psf	
19/32" Plywood Sheathing	2.5	psf	
Trusses at 24" o.c.	3.0	psf	
Insulation	1.8	psf	
(2) Layers 5/8" GWB	4.4	psf	
Misc/Mech	1.3	psf	
Total	15.0	psf	

FLOOR SYSTEM			
Live Load:			
Residential	40.0	psf	
Dead Load:			
Flooring	3.0	psf	
3/4" T & G Plywood	2.5	psf	
Floor Joists at 16" o.c.	2.5	psf	
Insulation	0.5	psf	
(1) Layers 5/8" GWB	2.2	psf	
Miscellaneous	1.3	psf	
Total	12.0	psf	

EXTERIOR WALL SYSTEM			
2x6 at 16" o.c.	1.7	psf	
Insulation	1.0	psf	
1/2" Plywood Sheathing	1.5	psf	
(2) layers 5/8" GWB	4.4	psf	
Misc	3.4	psf	
Total	12.0	psf	

EXTERIOR WALL W/THINSET BRICK			
2x6 at 16" o.c.	1.7		
Insulation	1.0	psf	
1/2" Plywood Sheathing	1.5	psf	
(2) layers 5/8" GWB	4.5	psf	
Brick Cladding	15.0	psf	
Total	22.0	psf	

INTERIOR WALL SYSTEM			
2x4 at 16" o.c.	1.1	psf	
Insulation	0.5	psf	
(2) Layers 5/8" GWB	4.4	psf	
Misc	2.0	psf	
Total	8.0	psf	

SEISMIC PARAMETERS:

Code Reference: ASCE 7-16

R = **6.5** Bearing Wall System, Wood Structural Panel Walls

Mapped Spectral Acceleration, S_s = **1.64**

Mapped Spectral Acceleration, S₁ = **0.62**

Soil Site Class = **D**

WIND PARAMETERS:

Code Reference: ASCE 7-16

Basic Wind Speed (3 second Gust) = **100** mph

Exposure : **B**

K_{zt} = **1.90**

SOIL PARAMETERS:

Soil Bearing Pressure = **3,500** psf competent native soil or structural fill
1/3 increase for short-term wind or seismic loading is acceptable

Frost Depth = **18** in

Lateral Wall Pressures:

Unrestrained Active Pressure = **35** pcf Cantilevered walls

Restrained Active Pressure = **50** pcf Plate Wall Design/Tank Walls

Passive Pressure = **300** pcf

Soil Friction Coeff. = **0.5**

ASCE 7 Hazards Report

Address:
8440 SE 82nd St
Mercer Island, Washington
98040

Standard: ASCE/SEI 7-22
Risk Category: II
Soil Class: Default

Latitude: 47.530412
Longitude: -122.226341
Elevation: 329.5217954889228 ft
(NAVD 88)

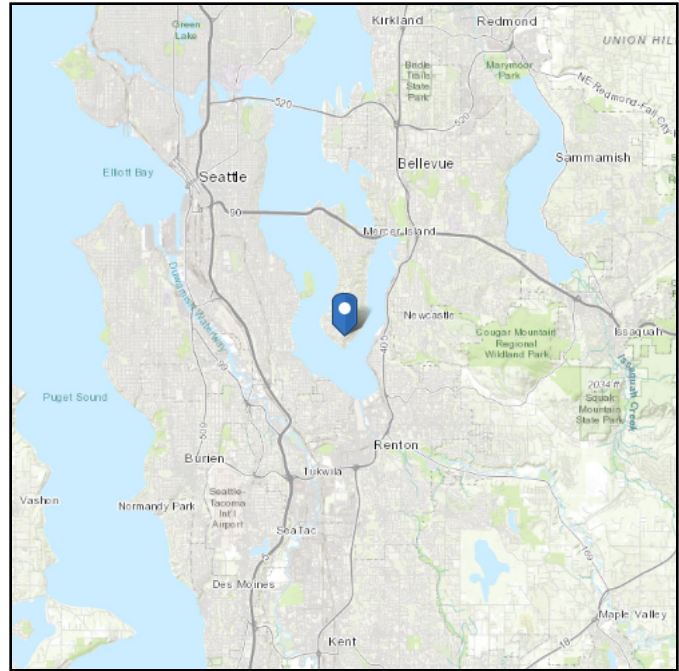
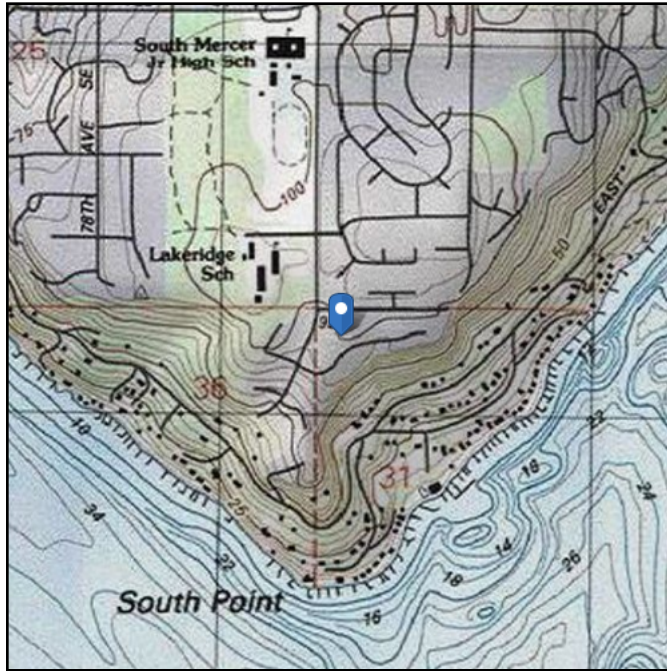

Wind

Results:

Wind Speed	98 Vmph
10-year MRI	67 Vmph
25-year MRI	74 Vmph
50-year MRI	78 Vmph
100-year MRI	83 Vmph
300-year MRI	92 Vmph
700-year MRI	98 Vmph
1,700-year MRI	104 Vmph
3,000-year MRI	109 Vmph
10,000-year MRI	118 Vmph
100,000-year MRI	136 Vmph
1,000,000-year MRI	154 Vmph

Data Source:

ASCE/SEI 7-22, Fig. 26.5-1B and Figs. CC.2-1–CC.2-4,
and Section 26.5.2

Date Accessed:

Wed Mar 15 2023

Mercer Island Wind Exposure and Wind Speed-Up (Topographic Effect)

by Development Services Group (DSG), City of Mercer Island
April 2009

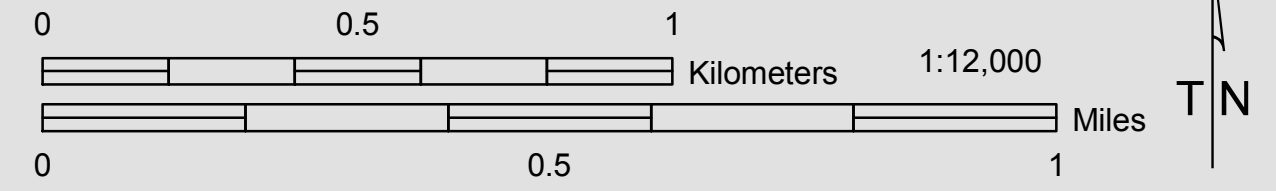

WIND EXPOSURE CATEGORIES & WIND SPEED-UP FACTORS (ICC Section 1609 & ASCE 7-05 Chapter 6)

It is the responsibility of the Owner (or their Design Professional) to review site conditions and determine the K_{zt} factor to be utilized for each specific project. The K_{zt} factors and wind exposure categories indicated on this map are the minimum values accepted by the City of Mercer Island without requiring the design professional to submit additional calculations and supporting topographic documentation (to verify the values utilized in their wind load determination).

Please note – The K_{zt} values indicated on this map are approximations based upon periodic calculations of representative samplings around Mercer Island. These values are intended for City of Mercer Island's plan review purposes only.

WIND EXPOSURE CATEGORIES:

Wind Exposure Category		Exposure 'C' (1500 feet from Lake)
		Exposure 'B' (all other areas)

WIND SPEED-UP (TOPOGRAPHIC EFFECT) - K_{zt} Factor :

K_{zt} Factor		$K_{zt} = 1.0$
		$K_{zt} = 1.3$
		$K_{zt} = 1.6$
		$K_{zt} = 1.9$

GENERAL NOTES FOR WIND EXPOSURE AND WIND SPEED-UP MAP

This map is the Wind Exposure Category and Wind Speed-up (Topographic Effects) Map for the City of Mercer Island. This map shows the minimum wind exposure category and the minimum wind speed-up, " K_{zt} " factor, which will be accepted without site specific documentation and calculation.

Other wind speed phenomena may occur on Mercer Island that is not specifically identified on this map. It is the responsibility of the Owner (or their Design Professional) to review site conditions and determine the appropriate design wind speed and exposure category for their specific project and location.

This map is for the sole use of the staff of the City of Mercer Island's Development Services Group (DSG) for the purposes of permit application evaluation. This map provides DSG staff a general assessment of Wind Exposure Category and Wind Speed-up (Topographic Effects). All areas have not been specifically evaluated and there may be locations that are not correctly represented on this map. It is the responsibility of individual property owners and map users to evaluate risk associated with their proposed development. No site-specific assessment of risk is implied or otherwise indicated by the City of Mercer Island with this map.

Information about data used for the map, references, and data limitation are all described the associated "Read Me" document. The digital version of this map is accompanied by a meta data file containing pertinent information about map construction. This data map is available on the City of Mercer Island website.

The City of Mercer Island is using guidance provided within ICC Section 1609 & ASCE 7-05 Chapter 6 regarding definitions used when creating this map.

DEFINITIONS:

K_{zt} factor: The topographic effect of wind speed-up at isolated hills, ridges, and escarpments constituting abrupt changes in the general topography, located in any exposure category, that meet all of the conditions noted in ASCE 7-05 Minimum Design Loads for Buildings and Other Structures, Section 6.5.7.

Exposure B: The wind exposure category that applies where the site in question is located a minimum of 1500 feet from the shoreline and the mean roof height is less than or equal to 30 feet per IBC 2006 section 1609.4.3.

Exposure C: The wind exposure category that applies where the site in question is located within 1500 feet from the shoreline per IBC 2006 section 1609.4.3.

Wind Speed: Minimum 85 mph 3-second gust per IRC Figure R301.2(4)

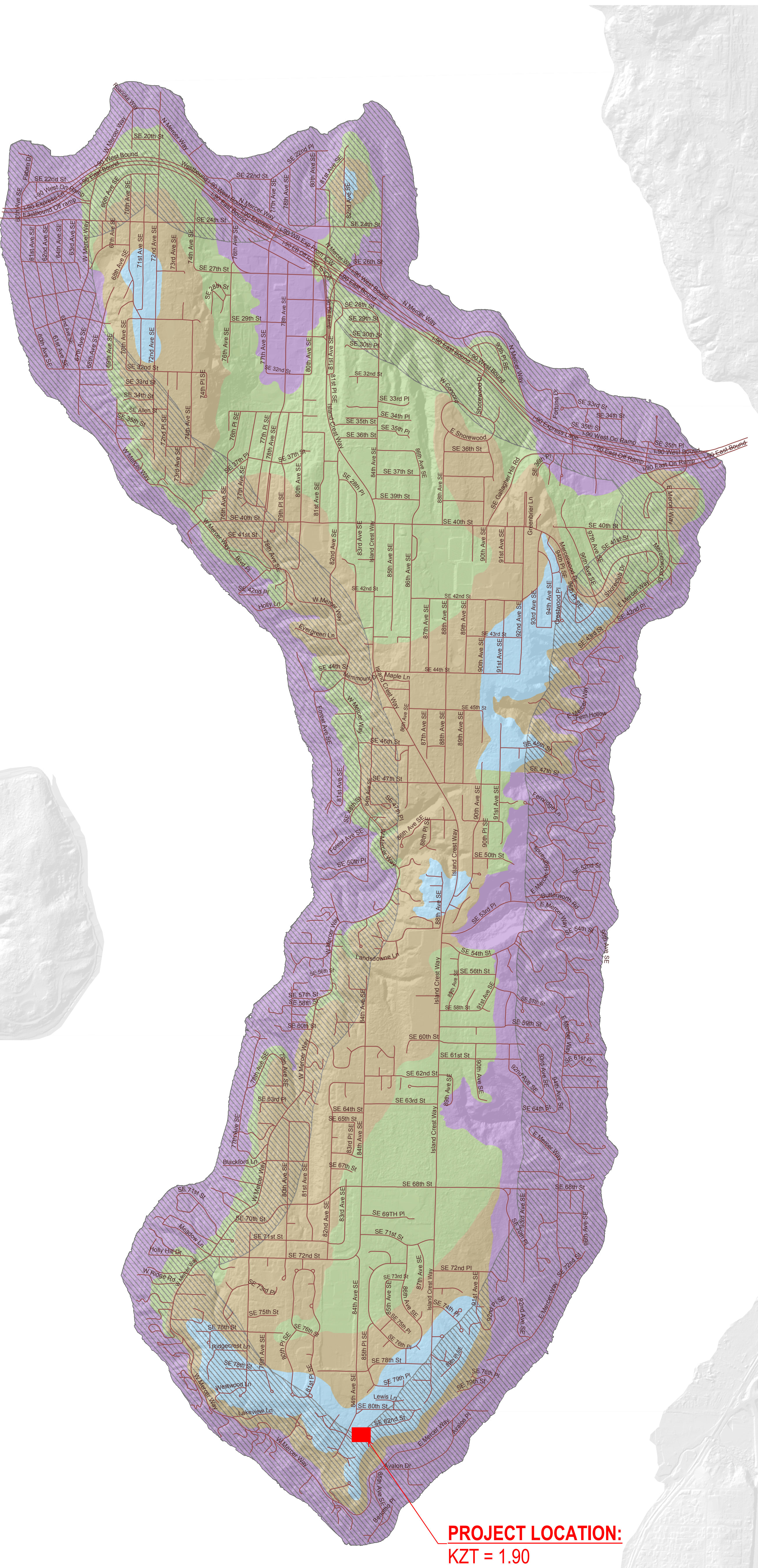

PROJECT LOCATION:
KZT = 1.90

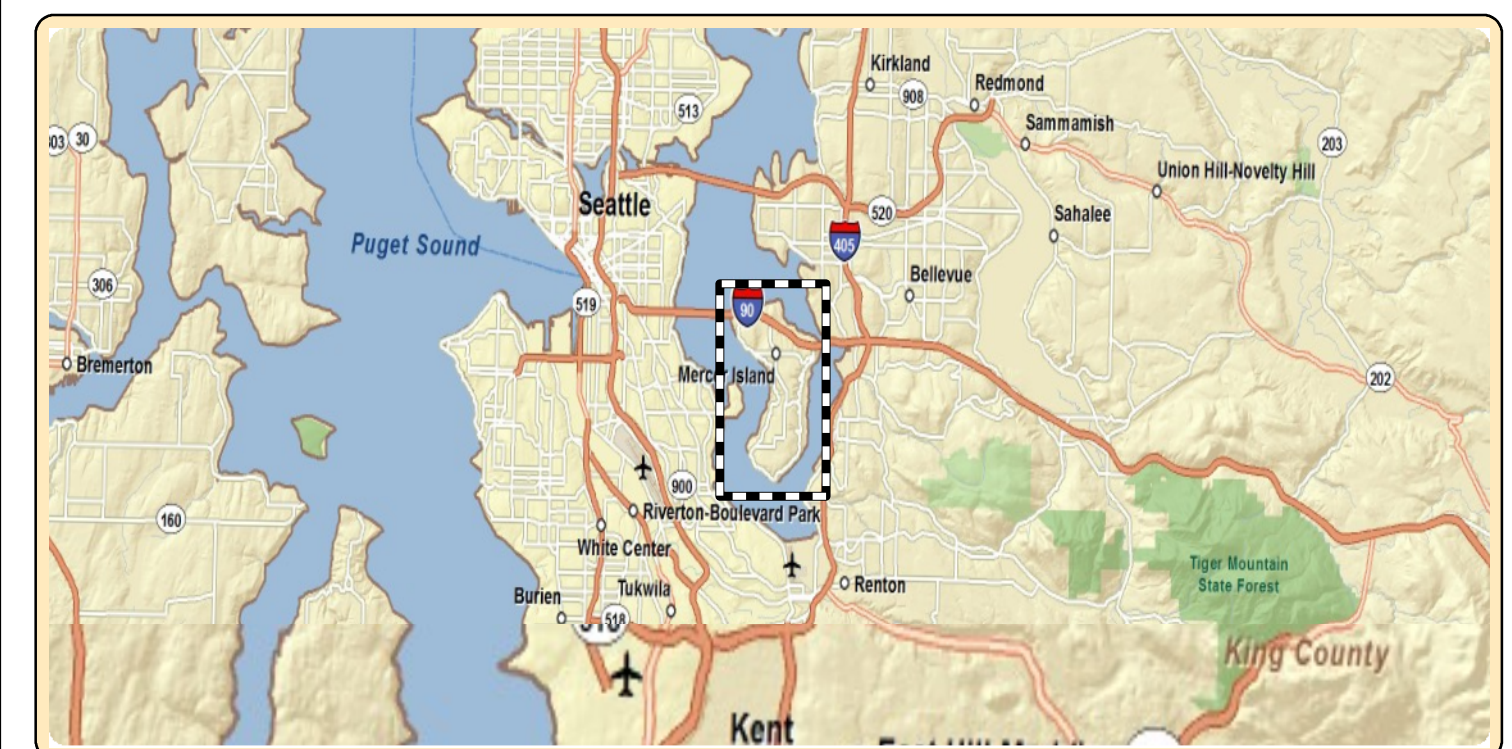



Value provided is 3-second gust wind speeds at 33 ft above ground for Exposure C Category, based on linear interpolation between contours. Wind speeds are interpolated in accordance with the 7-22 Standard. Wind speeds correspond to approximately a 7% probability of exceedance in 50 years (annual exceedance probability = 0.00143, MRI = 700 years). Values for 10-year MRI, 25-year MRI, 50-year MRI and 100-year MRI are Service Level wind speeds, all other wind speeds are Ultimate wind speeds.

Site is not in a hurricane-prone region as defined in ASCE/SEI 7-22 Section 26.2.

Site Soil Class:

Results:

PGA _M :	0.75	T _L :	6
S _{MS} :	1.8	S _S :	1.64
S _{M1} :	1.27	S ₁ :	0.62
S _{DS} :	1.2	V _{S30} :	260
S _{D1} :	0.85		

Seismic Design Category: D

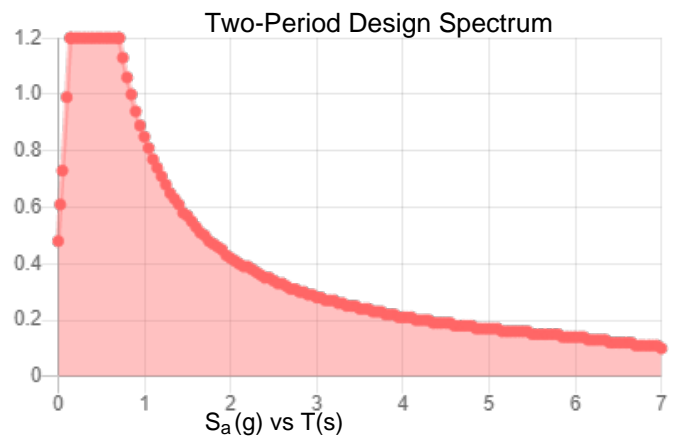
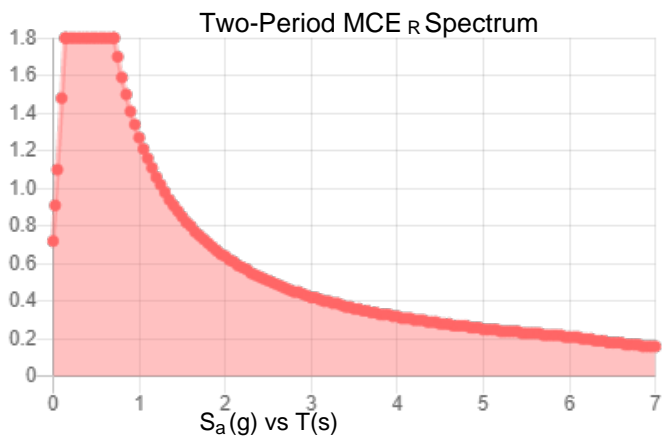
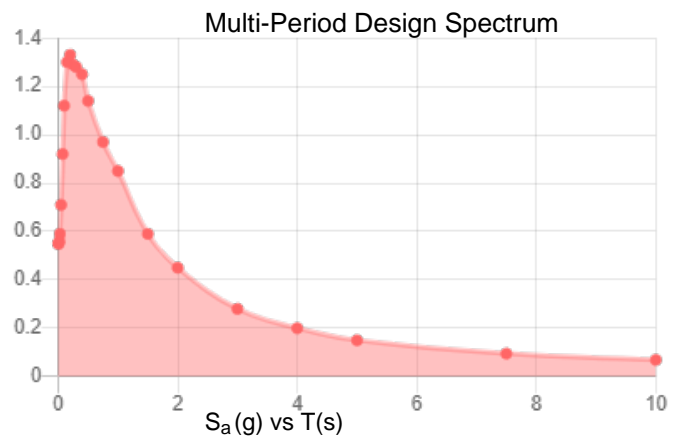
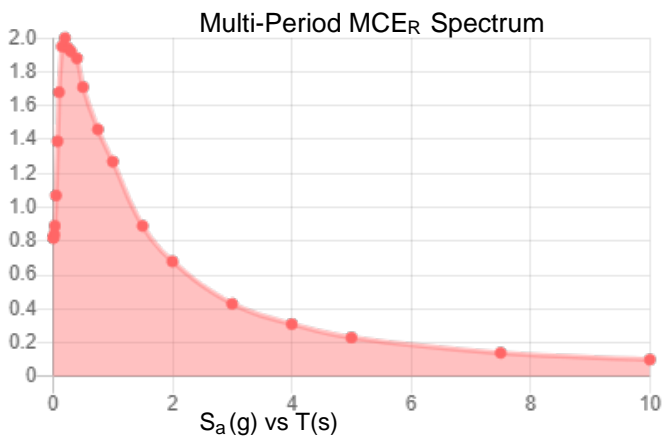

MCE_R Vertical Response Spectrum

Vertical ground motion data has not yet been made available by USGS.

Design Vertical Response Spectrum

Vertical ground motion data has not yet been made available by USGS.



Data Accessed:

Wed Mar 15 2023

Date Source:

USGS Seismic Design Maps based on ASCE/SEI 7-22 and ASCE/SEI 7-22 Table 1.5-2. Additional data for site-specific ground motion procedures in accordance with ASCE/SEI 7-22 Ch. 21 are available from USGS.



LONGITUDE
ONE TWENTY^o
ENGINEERING & DESIGN

Framing Calculations

Framing member calculation references are shown on
structural plans for ease of reference



(425) 636 3313



L120Engineering.com

Roof			
Member Name	Results (Max UTIL %)	Current Solution	Comments
RJ-1	Passed (52% M)	1 piece(s) 2 x 12 DF No.2 @ 16" OC	
2nd Floor			
Member Name	Results (Max UTIL %)	Current Solution	Comments
2H-1	Passed (68% M)	1 piece(s) 4 x 10 DF No.2	
2H-2	Passed (56% M)	1 piece(s) 4 x 8 DF No.2	
2H-3 (Beam Over 2nd floor Slider)	Passed (58% R)	1 piece(s) 5 1/2" x 15" 24F-V4 DF Glulam	
2H-3 (Inside Beam Over 2nd floor Slider)	Passed (45% ΔT)	1 piece(s) 5 1/2" x 9" 24F-V4 DF Glulam	
2J-1 (Long Span)	Passed (56% ΔL)	2 piece(s) 1 3/4" x 11 7/8" 2.0E Microllam® LVL @ 12" OC	
2J-1	Passed (56% M)	1 piece(s) 11 7/8" TJI@ 210 @ 16" OC	
2J-2	Passed (70% M)	1 piece(s) 11 7/8" TJI@ 210 @ 19.2" OC	
2J-3 (Deck Joist)	Passed (34% M)	1 piece(s) 2 x 6 DF No.2 @ 16" OC	
2J-4	Passed (75% M)	1 piece(s) 2 x 8 DF No.2 @ 16" OC	
2J-5	Passed (62% M)	1 piece(s) 11 7/8" TJI@ 210 @ 19.2" OC	
2J-6	Passed (25% R)	1 piece(s) 11 7/8" TJI@ 210 @ 16" OC	
2B-1 (Beam at the Master deck)	Passed (100% R)	1 piece(s) 7" x 14" 2.2E Parallam® PSL	
2B-2 (Beam under interior Master slider door wall)	Passed (95% ΔL)	1 piece(s) 7" x 11 7/8" 2.2E Parallam® PSL	
2B-2.1 (Beam directly under Master slider door)	Passed (32% R)	1 piece(s) 7" x 14" 2.2E Parallam® PSL	
2B-3	Passed (74% R)	1 piece(s) 5 1/4" x 11 7/8" 2.2E Parallam® PSL	
2B-4	Passed (85% ΔL)	1 piece(s) 7" x 16" 2.2E Parallam® PSL	
2B-4 (Steel Beam Opt)	Passed (86% ΔL)	1 piece(s) W10X33 (A992) ASTM Steel	
2B-5	Passed (91% ΔT)	1 piece(s) 7" x 11 1/4" 2.2E Parallam® PSL	
2B-6	Passed (87% R)	1 piece(s) 3 1/2" x 11 7/8" 2.2E Parallam® PSL	
2B-7	Passed (78% R)	1 piece(s) 1 3/4" x 11 7/8" 2.0E Microllam® LVL	
2B-8	Passed (67% ΔL)	2 piece(s) 1 3/4" x 11 7/8" 2.0E Microllam® LVL	
2B-9	Passed (95% ΔT)	1 piece(s) 5 1/2" x 9" 24F-V4 DF Glulam	
2B-10	Passed (86% M+)	1 piece(s) 5 1/2" x 10 1/2" 24F-V4 DF Glulam	
2B-11	Passed (38% ΔT)	1 piece(s) 5 1/2" x 10 1/2" 24F-V4 DF Glulam	
2B-12	Passed (69% R)	1 piece(s) 1 3/4" x 11 7/8" 2.0E Microllam® LVL	
2B-13	Passed (57% ΔL)	2 piece(s) 1 3/4" x 11 7/8" 2.0E Microllam® LVL	
2B-14	Passed (35% ΔL)	2 piece(s) 1 3/4" x 11 7/8" 2.0E Microllam® LVL	
2B-15	Passed (73% ΔL)	1 piece(s) 1 3/4" x 11 7/8" 2.0E Microllam® LVL	
2B-16	Passed (91% R)	1 piece(s) 1 3/4" x 11 7/8" 2.0E Microllam® LVL	
2B-17 (Beam over Living Room slider door)	Passed (53% M+)	1 piece(s) 3 1/2" x 15" 24F-V4 DF Glulam	

ForteWEB Software Operator	Job Notes
Harrison Kliegl L120 Engineering (425) 636-3313 hkliegl@l120engineering.com	



8/23/2024 3:55:53 AM UTC

ForteWEB v3.8

File Name: Granbois Residence

1st Floor			
Member Name	Results (Max UTIL %)	Current Solution	Comments
1H-1	Passed (69% M)	1 piece(s) 6 x 10 DF No.2	
1H-2	Passed (71% M)	1 piece(s) 4 x 10 DF No.2	
1H-3	Passed (47% M)	1 piece(s) 4 x 6 DF No.2	
1H-4	Passed (69% R)	1 piece(s) 3 1/2" x 7 1/2" 24F-V4 DF Glulam	
1J-1	Passed (67% M)	1 piece(s) 11 7/8" TJI@ 210 @ 12" OC	
1J-2	Passed (55% M)	1 piece(s) 11 7/8" TJI@ 210 @ 16" OC	
1B-1	Failed (100% R)	1 piece(s) 3 1/2" x 11 7/8" 2.2E Parallam® PSL	An excessive uplift of -2152 lbs at support located at 14' 8 1/2" failed this product.
1B-2	Failed (100% R)	1 piece(s) 5 1/4" x 11 7/8" 2.2E Parallam® PSL	Multiple Failures/Errors
1B-3	Failed (100% R)	1 piece(s) 5 1/4" x 11 7/8" 2.2E Parallam® PSL	Multiple Failures/Errors
1B-4	Failed (83% R)	1 piece(s) 5 1/4" x 11 7/8" 2.2E Parallam® PSL	An excessive uplift of -5500 lbs at support located at 3' 1" failed this product.
1B-5	Failed (100% R)	1 piece(s) 7" x 16" 2.2E Parallam® PSL	Multiple Failures/Errors
1B-6	Passed (100% R)	1 piece(s) 5 1/4" x 11 7/8" 2.2E Parallam® PSL	
1B-7	Passed (100% R)	1 piece(s) 7" x 16" 2.2E Parallam® PSL	
1B-8 (Beam over window well)	Failed (100% R)	1 piece(s) 5 1/4" x 11 7/8" 2.2E Parallam® PSL	An excessive uplift of -5771 lbs at support located at 9' 5 1/2" failed this product.
1B-9	Passed (72% ΔL)	2 piece(s) 1 3/4" x 11 7/8" 2.0E Microllam® LVL	
1B-10	Passed (84% M)	1 piece(s) 7" x 14" 2.2E Parallam® PSL	
1B-11	Passed (100% R)	1 piece(s) 3 1/2" x 11 7/8" 2.2E Parallam® PSL	
Basement			
Member Name	Results (Max UTIL %)	Current Solution	Comments
1C-1	Passed (58% f _{cp})	1 piece(s) 6 x 8 DF No.1	
1C-2	Passed (57% B/C)	1 piece(s) 6 x 8 DF No.1	
Garage			
Member Name	Results (Max UTIL %)	Current Solution	Comments
GH-1	Passed (85% R)	1 piece(s) 5 1/2" x 15" 24F-V4 DF Glulam	
GH-2	Passed (75% R)	1 piece(s) 3 1/2" x 9" 24F-V4 DF Glulam	

Uplift resolved via hardware provided per plan. Design OK!

ForteWEB Software Operator	Job Notes
Harrison Kliegl L120 Engineering (425) 636-3313 hkliegl@l120engineering.com	



8/23/2024 3:55:53 AM UTC
ForteWEB v3.8
File Name: Granbois Residence

Roof, RJ-1

1 piece(s) 2 x 12 DF No.2 @ 16" OC

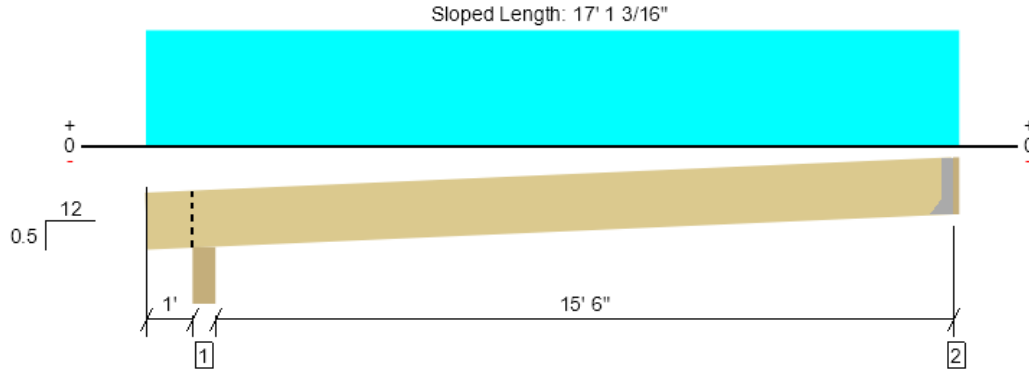

Drawing is Conceptual. All locations are measured from the outside face of left support (or left cantilever end). All dimensions are horizontal (typ.).

Design Results	Actual @ Location	Allowed	Result	LDF	Load: Combination (Pattern)
Member Reaction (lbs)	418 @ 16' 11 1/2"	1406 (1.50")	Passed (30%)	--	1.0 D + 1.0 S (Alt Spans)
Shear (lbs)	368 @ 16' 1/4"	2329	Passed (16%)	1.15	1.0 D + 1.0 S (Alt Spans)
Moment (Ft-lbs)	1636 @ 9' 1 1/2"	3138	Passed (52%)	1.15	1.0 D + 1.0 S (Alt Spans)
Live Load Defl. (in)	0.160 @ 9' 1 3/16"	0.787	Passed (L/999+)	--	1.0 D + 1.0 S (Alt Spans)
Total Load Defl. (in)	0.256 @ 9' 1 1/4"	1.050	Passed (L/738)	--	1.0 D + 1.0 S (Alt Spans)

Member Length : 17' 1/8"
 System : Roof
 Member Type : Joist
 Building Use : Residential
 Building Code : IBC 2021
 Design Methodology : ASD
 Member Pitch : 0.5/12

- Deflection criteria: LL (L/240) and TL (L/180).
- Overhang deflection criteria: LL (2L/240) and TL (2L/180).
- Allowed moment does not reflect the adjustment for the beam stability factor.
- A 15% increase in the moment capacity has been added to account for repetitive member usage.
- Applicable calculations are based on NDS.

Supports	Bearing Length			Loads to Supports (lbs)			Accessories
	Total	Available	Required	Dead	Snow	Factored	
1 - Beveled Plate - HF	5.50"	5.50"	1.50"	183	305	488	Blocking
2 - Hanger on 11 1/4" LSL Ledger	1.50"	Hanger ¹	1.50"	159	266	424	See note ¹

- Blocking Panels are assumed to carry no loads applied directly above them and the full load is applied to the member being designed.
- At hanger supports, the Total Bearing dimension is equal to the width of the material that is supporting the hanger
- ¹ See Connector grid below for additional information and/or requirements.

Lateral Bracing	Bracing Intervals	Comments
Top Edge (Lu)	9' 2" o/c	
Bottom Edge (Lu)	17' o/c	

- Maximum allowable bracing intervals based on applied load.
- Dimensions for lateral bracing intervals are measured along the length of the member for sloped conditions.

Connector: Simpson Strong-Tie							
Support	Model	Seat Length	Top Fasteners	Face Fasteners	Member Fasteners	Accessories	
2 - Face Mount Hanger	LRU28Z	1.94"	N/A	6-10dx1.5	5-10d		

- Refer to manufacturer notes and instructions for proper installation and use of all connectors.

Vertical Load	Location (Side)	Spacing	Dead (0.90)	Snow (1.15)	Comments
1 - Uniform (PSF)	0 to 17' 1"	16"	15.0	25.0	Roof Load

Weyerhaeuser Notes

Weyerhaeuser warrants that the sizing of its products will be in accordance with Weyerhaeuser product design criteria and published design values. Weyerhaeuser expressly disclaims any other warranties related to the software. Use of this software is not intended to circumvent the need for a design professional as determined by the authority having jurisdiction. The designer of record, builder or framer is responsible to assure that this calculation is compatible with the overall project. Accessories (Rim Board, Blocking Panels and Squash Blocks) are not designed by this software. Products manufactured at Weyerhaeuser facilities are third-party certified to sustainable forestry standards. Weyerhaeuser Engineered Lumber Products have been evaluated by ICC-ES under evaluation reports ESR-1153 and ESR-1387 and/or tested in accordance with applicable ASTM standards. For current code evaluation reports, Weyerhaeuser product literature and installation details refer to www.weyerhaeuser.com/woodproducts/document-library.

The product application, input design loads, dimensions and support information have been provided by ForteWEB Software Operator

ForteWEB Software Operator	Job Notes
Harrison Kliegl L120 Engineering (425) 636-3313 hkliegl@l120engineering.com	



8/23/2024 3:55:53 AM UTC
 ForteWEB v3.8, Engine: V8.4.1.24, Data: V8.1.6.3
 File Name: Granbois Residence

2nd Floor, 2H-1
1 piece(s) 4 x 10 DF No.2

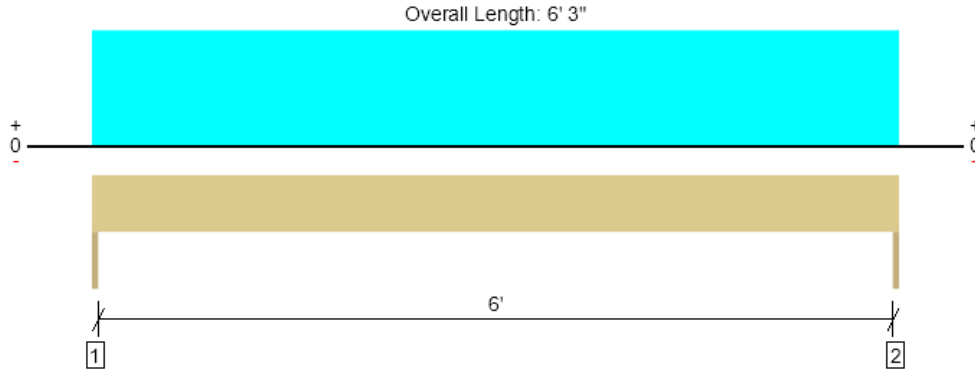

Drawing is Conceptual. All locations are measured from the outside face of left support (or left cantilever end). All dimensions are horizontal (typ.).

Design Results	Actual @ Location	Allowed	Result	LDF	Load: Combination (Pattern)
Member Reaction (lbs)	2217 @ 0	3281 (1.50")	Passed (68%)	--	1.0 D + 1.0 S (All Spans)
Shear (lbs)	1581 @ 10 3/4"	4468	Passed (35%)	1.15	1.0 D + 1.0 S (All Spans)
Moment (Ft-lbs)	3464 @ 3' 1 1/2"	5102	Passed (68%)	1.15	1.0 D + 1.0 S (All Spans)
Live Load Defl. (in)	0.040 @ 3' 1 1/2"	0.208	Passed (L/999+)	--	1.0 D + 1.0 S (All Spans)
Total Load Defl. (in)	0.066 @ 3' 1 1/2"	0.313	Passed (L/999+)	--	1.0 D + 1.0 S (All Spans)

Member Length : 6' 3"
 System : Wall
 Member Type : Header
 Building Use : Residential
 Building Code : IBC 2021
 Design Methodology : ASD

- Deflection criteria: LL (L/360) and TL (L/240).
- A 1.2% decrease in the moment capacity has been added to account for lateral stability.
- Applicable calculations are based on NDS.

Supports	Bearing Length			Loads to Supports (lbs)			Accessories
	Total	Available	Required	Dead	Snow	Factored	
1 - Trimmer - HF	1.50"	1.50"	1.50"	889	1328	2217	None
2 - Trimmer - HF	1.50"	1.50"	1.50"	889	1328	2217	None

Lateral Bracing	Bracing Intervals	Comments
Top Edge (Lu)	End Bearing Points	
Bottom Edge (Lu)	End Bearing Points	

Vertical Loads	Location	Tributary Width	Dead (0.90)	Snow (1.15)	Comments
0 - Self Weight (PLF)	0 to 6' 3"	N/A	8.2	--	
1 - Uniform (PSF)	0 to 6' 3"	17'	16.2	25.0	Roof Load

Weyerhaeuser Notes

Weyerhaeuser warrants that the sizing of its products will be in accordance with Weyerhaeuser product design criteria and published design values. Weyerhaeuser expressly disclaims any other warranties related to the software. Use of this software is not intended to circumvent the need for a design professional as determined by the authority having jurisdiction. The designer of record, builder or framer is responsible to assure that this calculation is compatible with the overall project. Accessories (Rim Board, Blocking Panels and Squash Blocks) are not designed by this software. Products manufactured at Weyerhaeuser facilities are third-party certified to sustainable forestry standards. Weyerhaeuser Engineered Lumber Products have been evaluated by ICC-ES under evaluation reports ESR-1153 and ESR-1387 and/or tested in accordance with applicable ASTM standards. For current code evaluation reports, Weyerhaeuser product literature and installation details refer to www.weyerhaeuser.com/woodproducts/document-library.

The product application, input design loads, dimensions and support information have been provided by ForteWEB Software Operator

ForteWEB Software Operator	Job Notes
Harrison Kliegl L120 Engineering (425) 636-3313 hkliegl@l120engineering.com	



2nd Floor, 2H-2
1 piece(s) 4 x 8 DF No.2

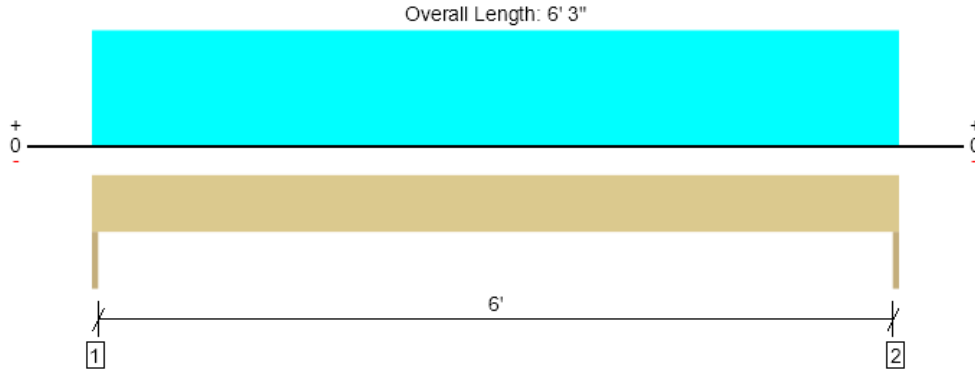

Drawing is Conceptual. All locations are measured from the outside face of left support (or left cantilever end). All dimensions are horizontal (typ.).

Design Results	Actual @ Location	Allowed	Result	LDF	Load: Combination (Pattern)
Member Reaction (lbs)	1230 @ 0	3281 (1.50")	Passed (37%)	--	1.0 D + 1.0 S (All Spans)
Shear (lbs)	943 @ 8 3/4"	3502	Passed (27%)	1.15	1.0 D + 1.0 S (All Spans)
Moment (Ft-lbs)	1922 @ 3' 1 1/2"	3405	Passed (56%)	1.15	1.0 D + 1.0 S (All Spans)
Live Load Defl. (in)	0.043 @ 3' 1 1/2"	0.208	Passed (L/999+)	--	1.0 D + 1.0 S (All Spans)
Total Load Defl. (in)	0.076 @ 3' 1 1/2"	0.313	Passed (L/987)	--	1.0 D + 1.0 S (All Spans)

Member Length : 6' 3"
 System : Wall
 Member Type : Header
 Building Use : Residential
 Building Code : IBC 2021
 Design Methodology : ASD

- Deflection criteria: LL (L/360) and TL (L/240).
- A 1% decrease in the moment capacity has been added to account for lateral stability.
- Applicable calculations are based on NDS.

Supports	Bearing Length			Loads to Supports (lbs)			Accessories
	Total	Available	Required	Dead	Snow	Factored	
1 - Trimmer - HF	1.50"	1.50"	1.50"	527	703	1230	None
2 - Trimmer - HF	1.50"	1.50"	1.50"	527	703	1230	None

Lateral Bracing	Bracing Intervals	Comments
Top Edge (Lu)	End Bearing Points	
Bottom Edge (Lu)	End Bearing Points	

Vertical Loads	Location	Tributary Width	Dead (0.90)	Snow (1.15)	Comments
0 - Self Weight (PLF)	0 to 6' 3"	N/A	6.4	--	
1 - Uniform (PSF)	0 to 6' 3"	9'	18.0	25.0	Roof Load

Weyerhaeuser Notes

Weyerhaeuser warrants that the sizing of its products will be in accordance with Weyerhaeuser product design criteria and published design values. Weyerhaeuser expressly disclaims any other warranties related to the software. Use of this software is not intended to circumvent the need for a design professional as determined by the authority having jurisdiction. The designer of record, builder or framer is responsible to assure that this calculation is compatible with the overall project. Accessories (Rim Board, Blocking Panels and Squash Blocks) are not designed by this software. Products manufactured at Weyerhaeuser facilities are third-party certified to sustainable forestry standards. Weyerhaeuser Engineered Lumber Products have been evaluated by ICC-ES under evaluation reports ESR-1153 and ESR-1387 and/or tested in accordance with applicable ASTM standards. For current code evaluation reports, Weyerhaeuser product literature and installation details refer to www.weyerhaeuser.com/woodproducts/document-library.

The product application, input design loads, dimensions and support information have been provided by ForteWEB Software Operator

ForteWEB Software Operator	Job Notes
Harrison Kliegl L120 Engineering (425) 636-3313 hkriegl@l120engineering.com	



2nd Floor, 2H-3 (Beam Over 2nd floor Slider)
1 piece(s) 5 1/2" x 15" 24F-V4 DF Glulam

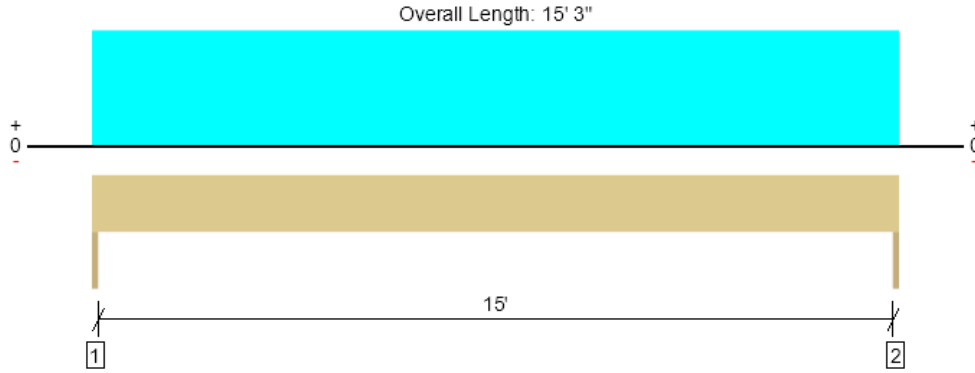

Drawing is Conceptual. All locations are measured from the outside face of left support (or left cantilever end). All dimensions are horizontal (typ.).

Design Results	Actual @ Location	Allowed	Result	LDF	Load: Combination (Pattern)
Member Reaction (lbs)	3089 @ 0	5363 (1.50")	Passed (58%)	--	1.0 D + 1.0 S (All Spans)
Shear (lbs)	2532 @ 1' 4 1/2"	16761	Passed (15%)	1.15	1.0 D + 1.0 S (All Spans)
Pos Moment (Ft-lbs)	11775 @ 7' 7 1/2"	45623	Passed (26%)	1.15	1.0 D + 1.0 S (All Spans)
Live Load Defl. (in)	0.082 @ 7' 7 1/2"	0.508	Passed (L/999+)	--	1.0 D + 1.0 S (All Spans)
Total Load Defl. (in)	0.177 @ 7' 7 1/2"	0.762	Passed (L/999+)	--	1.0 D + 1.0 S (All Spans)

Member Length : 15' 3"
 System : Wall
 Member Type : Header
 Building Use : Residential
 Building Code : IBC 2021
 Design Methodology : ASD

- Deflection criteria: LL (L/360) and TL (L/240).
- A 3.8% decrease in the moment capacity has been added to account for lateral stability.
- Critical positive moment adjusted by a volume/size factor of 1.00 that was calculated using length L = 15' 3".
- The effects of positive or negative camber have not been accounted for when calculating deflection.
- The specified glulam is assumed to have its strong laminations at the bottom of the beam. Install with proper side up as indicated by the manufacturer.
- Applicable calculations are based on NDS.

Supports	Bearing Length			Loads to Supports (lbs)			Accessories
	Total	Available	Required	Dead	Snow	Factored	
1 - Trimmer - HF	1.50"	1.50"	1.50"	1659	1430	3089	None
2 - Trimmer - HF	1.50"	1.50"	1.50"	1659	1430	3089	None

Lateral Bracing	Bracing Intervals	Comments
Top Edge (Lu)	End Bearing Points	
Bottom Edge (Lu)	End Bearing Points	

Vertical Loads	Location	Tributary Width	Dead (0.90)	Snow (1.15)	Comments
0 - Self Weight (PLF)	0 to 15' 3"	N/A	20.0	--	
1 - Uniform (PSF)	0 to 15' 3"	7' 6"	13.0	25.0	Roof Load
2 - Uniform (PLF)	0 to 15' 3"	N/A	100.0	-	Slider Door if Hanging

Weyerhaeuser Notes

Weyerhaeuser warrants that the sizing of its products will be in accordance with Weyerhaeuser product design criteria and published design values. Weyerhaeuser expressly disclaims any other warranties related to the software. Use of this software is not intended to circumvent the need for a design professional as determined by the authority having jurisdiction. The designer of record, builder or framer is responsible to assure that this calculation is compatible with the overall project. Accessories (Rim Board, Blocking Panels and Squash Blocks) are not designed by this software. Products manufactured at Weyerhaeuser facilities are third-party certified to sustainable forestry standards. Weyerhaeuser Engineered Lumber Products have been evaluated by ICC-ES under evaluation reports ESR-1153 and ESR-1387 and/or tested in accordance with applicable ASTM standards. For current code evaluation reports, Weyerhaeuser product literature and installation details refer to www.weyerhaeuser.com/woodproducts/document-library.

The product application, input design loads, dimensions and support information have been provided by ForteWEB Software Operator

ForteWEB Software Operator	Job Notes
Harrison Kliegl L120 Engineering (425) 636-3313 hkliegl@l120engineering.com	



2nd Floor, 2H-3 (Inside Beam Over 2nd floor Slider)
1 piece(s) 5 1/2" x 9" 24F-V4 DF Glulam

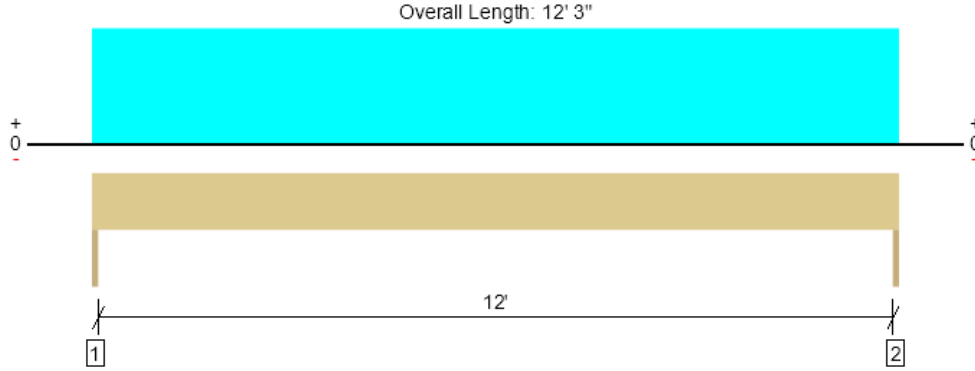

Drawing is Conceptual. All locations are measured from the outside face of left support (or left cantilever end). All dimensions are horizontal (typ.).

Design Results	Actual @ Location	Allowed	Result	LDF	Load: Combination (Pattern)
Member Reaction (lbs)	2009 @ 0	5363 (1.50")	Passed (37%)	--	1.0 D + 1.0 S (All Spans)
Shear (lbs)	1722 @ 10 1/2"	10057	Passed (17%)	1.15	1.0 D + 1.0 S (All Spans)
Pos Moment (Ft-lbs)	6153 @ 6' 1 1/2"	16847	Passed (37%)	1.15	1.0 D + 1.0 S (All Spans)
Live Load Defl. (in)	0.147 @ 6' 1 1/2"	0.408	Passed (L/997)	--	1.0 D + 1.0 S (All Spans)
Total Load Defl. (in)	0.276 @ 6' 1 1/2"	0.613	Passed (L/532)	--	1.0 D + 1.0 S (All Spans)

Member Length : 12' 3"
 System : Wall
 Member Type : Header
 Building Use : Residential
 Building Code : IBC 2021
 Design Methodology : ASD

- Deflection criteria: LL (L/360) and TL (L/240).
- A 1.3% decrease in the moment capacity has been added to account for lateral stability.
- Critical positive moment adjusted by a volume/size factor of 1.00 that was calculated using length L = 12' 3".
- The effects of positive or negative camber have not been accounted for when calculating deflection.
- The specified glulam is assumed to have its strong laminations at the bottom of the beam. Install with proper side up as indicated by the manufacturer.
- Applicable calculations are based on NDS.

Supports	Bearing Length			Loads to Supports (lbs)			Accessories
	Total	Available	Required	Dead	Snow	Factored	
1 - Trimmer - HF	1.50"	1.50"	1.50"	937	1072	2009	None
2 - Trimmer - HF	1.50"	1.50"	1.50"	937	1072	2009	None

Lateral Bracing	Bracing Intervals	Comments
Top Edge (Lu)	End Bearing Points	
Bottom Edge (Lu)	End Bearing Points	

Vertical Loads	Location	Tributary Width	Dead (0.90)	Snow (1.15)	Comments
0 - Self Weight (PLF)	0 to 12' 3"	N/A	12.0	--	
1 - Uniform (PSF)	0 to 12' 3"	7'	13.0	25.0	Roof Load
2 - Uniform (PLF)	0 to 12' 3"	N/A	50.0	-	Slider Door if Hanging

Weyerhaeuser Notes

Weyerhaeuser warrants that the sizing of its products will be in accordance with Weyerhaeuser product design criteria and published design values. Weyerhaeuser expressly disclaims any other warranties related to the software. Use of this software is not intended to circumvent the need for a design professional as determined by the authority having jurisdiction. The designer of record, builder or framer is responsible to assure that this calculation is compatible with the overall project. Accessories (Rim Board, Blocking Panels and Squash Blocks) are not designed by this software. Products manufactured at Weyerhaeuser facilities are third-party certified to sustainable forestry standards. Weyerhaeuser Engineered Lumber Products have been evaluated by ICC-ES under evaluation reports ESR-1153 and ESR-1387 and/or tested in accordance with applicable ASTM standards. For current code evaluation reports, Weyerhaeuser product literature and installation details refer to www.weyerhaeuser.com/woodproducts/document-library.

The product application, input design loads, dimensions and support information have been provided by ForteWEB Software Operator

ForteWEB Software Operator	Job Notes
Harrison Kliegl L120 Engineering (425) 636-3313 hkriegl@l120engineering.com	



2nd Floor, 2J-1 (Long Span)

2 piece(s) 1 3/4" x 11 7/8" 2.0E Microllam® LVL @ 12" OC

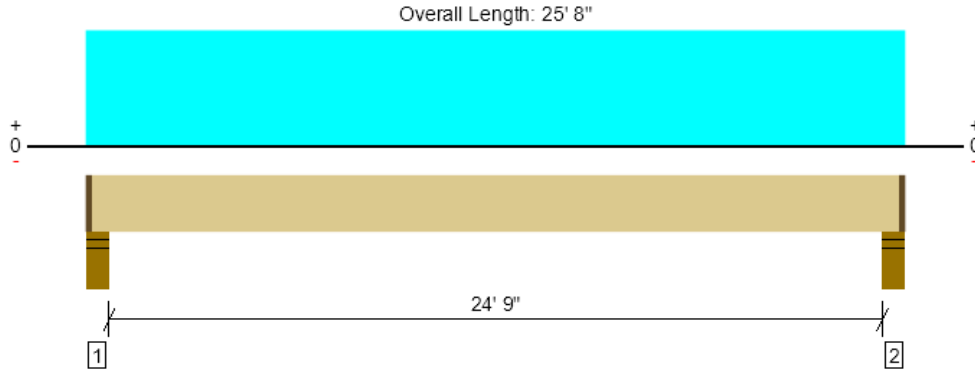

Drawing is Conceptual. All locations are measured from the outside face of left support (or left cantilever end). All dimensions are horizontal (typ.).

Design Results	Actual @ Location	Allowed	Result	LDF	Load: Combination (Pattern)
Member Reaction (lbs)	661 @ 4 1/2"	8750 (4.00")	Passed (8%)	--	1.0 D + 1.0 L (All Spans)
Shear (lbs)	592 @ 1' 5 3/8"	7897	Passed (7%)	1.00	1.0 D + 1.0 L (All Spans)
Moment (Ft-lbs)	4035 @ 12' 10"	18562	Passed (22%)	1.00	1.0 D + 1.0 L (All Spans)
Live Load Defl. (in)	0.349 @ 12' 10"	0.623	Passed (L/857)	--	1.0 D + 1.0 L (All Spans)
Total Load Defl. (in)	0.454 @ 12' 10"	1.246	Passed (L/659)	--	1.0 D + 1.0 L (All Spans)
TJ-Pro™ Rating	42	40	Passed	--	--

Member Length : 25' 5"
 System : Floor
 Member Type : Joist
 Building Use : Residential
 Building Code : IBC 2021
 Design Methodology : ASD

- Deflection criteria: LL (L/480) and TL (L/240).
- A 4% increase in the moment capacity has been added to account for repetitive member usage.
- A structural analysis of the deck has not been performed.
- Deflection analysis is based on composite action with a single layer of 23/32" Weyerhaeuser Edge™ Panel (24" Span Rating) that is glued and nailed down.
- Additional considerations for the TJ-Pro™ Rating include: None.

Supports	Bearing Length			Loads to Supports (lbs)			Accessories
	Total	Available	Required	Dead	Floor Live	Factored	
1 - Stud wall - DF	5.50"	4.00"	1.50"	154	513	667	1 1/2" Rim Board
2 - Stud wall - DF	5.50"	4.00"	1.50"	154	513	667	1 1/2" Rim Board

• Rim Board is assumed to carry all loads applied directly above it, bypassing the member being designed.

Lateral Bracing	Bracing Intervals	Comments
Top Edge (Lu)	Continuous	
Bottom Edge (Lu)	End Bearing Points	

Vertical Load	Location (Side)	Spacing	Dead (0.90)	Floor Live (1.00)	Comments
1 - Uniform (PSF)	0 to 25' 8"	12"	12.0	40.0	Floor Load

Weyerhaeuser Notes

Weyerhaeuser warrants that the sizing of its products will be in accordance with Weyerhaeuser product design criteria and published design values. Weyerhaeuser expressly disclaims any other warranties related to the software. Use of this software is not intended to circumvent the need for a design professional as determined by the authority having jurisdiction. The designer of record, builder or framer is responsible to assure that this calculation is compatible with the overall project. Accessories (Rim Board, Blocking Panels and Squash Blocks) are not designed by this software. Products manufactured at Weyerhaeuser facilities are third-party certified to sustainable forestry standards. Weyerhaeuser Engineered Lumber Products have been evaluated by ICC-ES under evaluation reports ESR-1153 and ESR-1387 and/or tested in accordance with applicable ASTM standards. For current code evaluation reports, Weyerhaeuser product literature and installation details refer to www.weyerhaeuser.com/woodproducts/document-library.

The product application, input design loads, dimensions and support information have been provided by ForteWEB Software Operator

ForteWEB Software Operator	Job Notes
Harrison Kliegl L120 Engineering (425) 636-3313 hkriegl@l120engineering.com	



2nd Floor, 2J-1

1 piece(s) 11 7/8" TJI@ 210 @ 16" OC

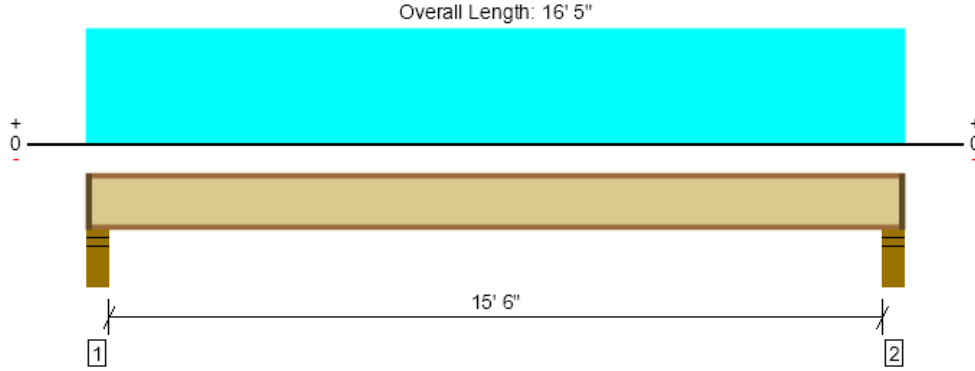

Drawing is Conceptual. All locations are measured from the outside face of left support (or left cantilever end). All dimensions are horizontal (typ.).

Design Results	Actual @ Location	Allowed	Result	LDF	Load: Combination (Pattern)
Member Reaction (lbs)	560 @ 4 1/2"	1460 (3.50")	Passed (38%)	1.00	1.0 D + 1.0 L (All Spans)
Shear (lbs)	537 @ 5 1/2"	1655	Passed (32%)	1.00	1.0 D + 1.0 L (All Spans)
Moment (Ft-lbs)	2127 @ 8' 2 1/2"	3795	Passed (56%)	1.00	1.0 D + 1.0 L (All Spans)
Live Load Defl. (in)	0.216 @ 8' 2 1/2"	0.392	Passed (L/870)	--	1.0 D + 1.0 L (All Spans)
Total Load Defl. (in)	0.281 @ 8' 2 1/2"	0.783	Passed (L/669)	--	1.0 D + 1.0 L (All Spans)
TJ-Pro™ Rating	47	40	Passed	--	--

Member Length : 16' 2"
 System : Floor
 Member Type : Joist
 Building Use : Residential
 Building Code : IBC 2021
 Design Methodology : ASD

- Deflection criteria: LL (L/480) and TL (L/240).
- Allowed moment does not reflect the adjustment for the beam stability factor.
- A structural analysis of the deck has not been performed.
- Deflection analysis is based on composite action with a single layer of 23/32" Weyerhaeuser Edge™ Panel (24" Span Rating) that is glued and nailed down.
- Additional considerations for the TJ-Pro™ Rating include: None.

Supports	Bearing Length			Loads to Supports (lbs)			Accessories
	Total	Available	Required	Dead	Floor Live	Factored	
1 - Stud wall - HF	5.50"	4.00"	1.75"	131	438	569	1 1/2" Rim Board
2 - Stud wall - HF	5.50"	4.00"	1.75"	131	438	569	1 1/2" Rim Board

• Rim Board is assumed to carry all loads applied directly above it, bypassing the member being designed.

Lateral Bracing	Bracing Intervals	Comments
Top Edge (Lu)	5' o/c	
Bottom Edge (Lu)	16' 2" o/c	

- TJI joists are only analyzed using Maximum Allowable bracing solutions.
- Maximum allowable bracing intervals based on applied load.

Vertical Load	Location	Spacing	Dead (0.90)	Floor Live (1.00)	Comments
1 - Uniform (PSF)	0 to 16' 5"	16"	12.0	40.0	Floor Load

Weyerhaeuser Notes

Weyerhaeuser warrants that the sizing of its products will be in accordance with Weyerhaeuser product design criteria and published design values. Weyerhaeuser expressly disclaims any other warranties related to the software. Use of this software is not intended to circumvent the need for a design professional as determined by the authority having jurisdiction. The designer of record, builder or framer is responsible to assure that this calculation is compatible with the overall project. Accessories (Rim Board, Blocking Panels and Squash Blocks) are not designed by this software. Products manufactured at Weyerhaeuser facilities are third-party certified to sustainable forestry standards. Weyerhaeuser Engineered Lumber Products have been evaluated by ICC-ES under evaluation reports ESR-1153 and ESR-1387 and/or tested in accordance with applicable ASTM standards. For current code evaluation reports, Weyerhaeuser product literature and installation details refer to www.weyerhaeuser.com/woodproducts/document-library.

The product application, input design loads, dimensions and support information have been provided by ForteWEB Software Operator

ForteWEB Software Operator	Job Notes
Harrison Kliegl L120 Engineering (425) 636-3313 hkliegl@l120engineering.com	



2nd Floor, 2J-2

1 piece(s) 11 7/8" TJI® 210 @ 19.2" OC

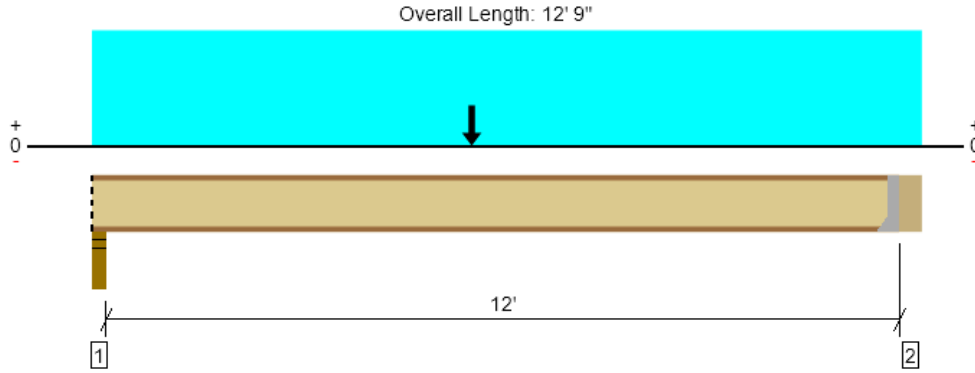

Drawing is Conceptual. All locations are measured from the outside face of left support (or left cantilever end). All dimensions are horizontal (typ.).

Design Results	Actual @ Location	Allowed	Result	LDF	Load: Combination (Pattern)
Member Reaction (lbs)	662 @ 12' 3 1/2"	1005 (1.75")	Passed (66%)	1.00	1.0 D + 1.0 L (All Spans)
Shear (lbs)	669 @ 3 1/2"	1655	Passed (40%)	1.00	1.0 D + 1.0 L (All Spans)
Moment (Ft-lbs)	3042 @ 6'	4364	Passed (70%)	1.15	1.0 D + 0.75 L + 0.75 S (All Spans)
Live Load Defl. (in)	0.131 @ 6'	0.302	Passed (L/999+)	--	1.0 D + 0.75 L + 0.75 S (All Spans)
Total Load Defl. (in)	0.232 @ 6'	0.604	Passed (L/625)	--	1.0 D + 0.75 L + 0.75 S (All Spans)
TJ-Pro™ Rating	52	40	Passed	--	--

Member Length : 12' 3 1/2"
 System : Floor
 Member Type : Joist
 Building Use : Residential
 Building Code : IBC 2021
 Design Methodology : ASD

- Deflection criteria: LL (L/480) and TL (L/240).
- Allowed moment does not reflect the adjustment for the beam stability factor.
- A structural analysis of the deck has not been performed.
- Deflection analysis is based on composite action with a single layer of 23/32" Weyerhaeuser Edge™ Panel (24" Span Rating) that is glued and nailed down.
- Additional considerations for the TJ-Pro™ Rating include: None.

Supports	Bearing Length			Loads to Supports (lbs)				Accessories
	Total	Available	Required	Dead	Floor Live	Snow	Factored	
1 - Stud wall - HF	3.50"	3.50"	1.75"	293	400	187	734	Blocking
2 - Hanger on 11 7/8" PSL beam	5.50"	Hanger ¹	1.75" / - ²	284	416	173	726	See note ¹

- Blocking Panels are assumed to carry no loads applied directly above them and the full load is applied to the member being designed.
- At hanger supports, the Total Bearing dimension is equal to the width of the material that is supporting the hanger
- ¹ See Connector grid below for additional information and/or requirements.
- ² Required Bearing Length / Required Bearing Length with Web Stiffeners

Lateral Bracing	Bracing Intervals	Comments
Top Edge (Lu)	4' 2" o/c	
Bottom Edge (Lu)	12' 4" o/c	

- TJI joists are only analyzed using Maximum Allowable bracing solutions.
- Maximum allowable bracing intervals based on applied load.

Connector: Simpson Strong-Tie

Support	Model	Seat Length	Top Fasteners	Face Fasteners	Member Fasteners	Accessories
2 - Face Mount Hanger	IUS2.06/11.88	2.00"	N/A	10-10dx1.5	2-Strong-Grip	

- Refer to manufacturer notes and instructions for proper installation and use of all connectors.

Vertical Loads	Location	Spacing	Dead (0.90)	Floor Live (1.00)	Snow (1.15)	Comments
1 - Uniform (PSF)	0 to 12' 9"	19.2"	12.0	40.0	-	Floor Load
2 - Point (PLF)	6'	19.2"	208.0	-	225.0	DL = 12 psf * 9ft + 100 plf LL = 25 psf * 9 ft

ForteWEB Software Operator	Job Notes
Harrison Kliegl L120 Engineering (425) 636-3313 hkliegl@l120engineering.com	



8/23/2024 3:55:53 AM UTC
 ForteWEB v3.8, Engine: V8.4.1.24, Data: V8.1.6.3
 File Name: Granbois Residence

Weyerhaeuser Notes

Weyerhaeuser warrants that the sizing of its products will be in accordance with Weyerhaeuser product design criteria and published design values. Weyerhaeuser expressly disclaims any other warranties related to the software. Use of this software is not intended to circumvent the need for a design professional as determined by the authority having jurisdiction. The designer of record, builder or framer is responsible to assure that this calculation is compatible with the overall project. Accessories (Rim Board, Blocking Panels and Squash Blocks) are not designed by this software. Products manufactured at Weyerhaeuser facilities are third-party certified to sustainable forestry standards. Weyerhaeuser Engineered Lumber Products have been evaluated by ICC-ES under evaluation reports ESR-1153 and ESR-1387 and/or tested in accordance with applicable ASTM standards. For current code evaluation reports, Weyerhaeuser product literature and installation details refer to www.weyerhaeuser.com/woodproducts/document-library.

The product application, input design loads, dimensions and support information have been provided by ForteWEB Software Operator

ForteWEB Software Operator	Job Notes
Harrison Kliegl L120 Engineering (425) 636-3313 hkliegl@l120engineering.com	



2nd Floor, 2J-3 (Deck Joist)
1 piece(s) 2 x 6 DF No.2 @ 16" OC

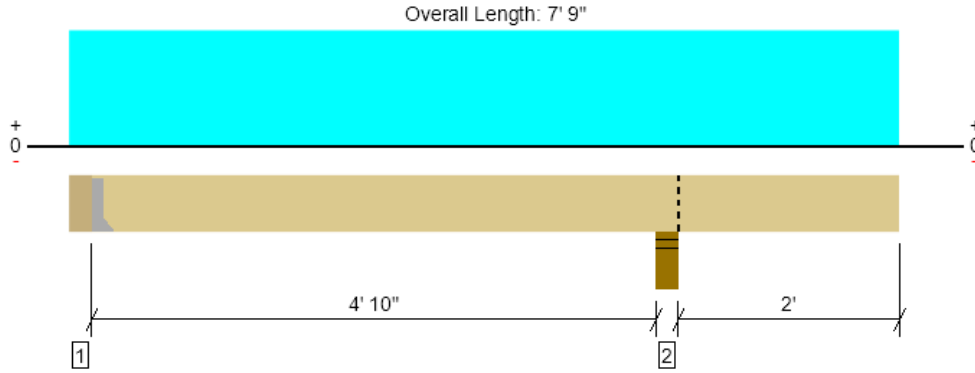

Drawing is Conceptual. All locations are measured from the outside face of left support (or left cantilever end). All dimensions are horizontal (typ.).

Design Results	Actual @ Location	Allowed	Result	LDF	Load: Combination (Pattern)
Member Reaction (lbs)	242 @ 5' 1/2"	1406 (1.50")	Passed (17%)	--	1.0 D + 0.75 L + 0.75 S (Alt Spans)
Shear (lbs)	224 @ 4' 10"	990	Passed (23%)	1.00	1.0 D + 1.0 L (All Spans)
Moment (Ft-lbs)	288 @ 2' 10 7/8"	848	Passed (34%)	1.00	1.0 D + 1.0 L (Alt Spans)
Live Load Defl. (in)	0.036 @ 2' 11 7/8"	0.127	Passed (L/999+)	--	1.0 D + 1.0 L (Alt Spans)
Total Load Defl. (in)	0.052 @ 7' 9"	0.223	Passed (2L/999+)	--	1.0 D + 1.0 L (Alt Spans)
TJ-Pro™ Rating	N/A	N/A	N/A	--	N/A

Member Length : 7' 3 1/2"
 System : Floor
 Member Type : Joist
 Building Use : Residential
 Building Code : IBC 2021
 Design Methodology : ASD

- Deflection criteria: LL (L/480) and TL (L/240).
- Overhang deflection criteria: LL (2L/480) and TL (2L/240).
- A 15% increase in the moment capacity has been added to account for repetitive member usage.
- Applicable calculations are based on NDS.
- No composite action between deck and joist was considered in analysis.

Supports	Bearing Length			Loads to Supports (lbs)				Accessories
	Total	Available	Required	Dead	Floor Live	Snow	Factored	
1 - Hanger on 5 1/2" DF beam	5.50"	Hanger ¹	1.50"	40	239/-3	91	288	See note ¹
2 - Stud wall - DF	5.50"	5.50"	1.50"	84	420	175	530	Blocking

- Blocking Panels are assumed to carry no loads applied directly above them and the full load is applied to the member being designed.
- At hanger supports, the Total Bearing dimension is equal to the width of the material that is supporting the hanger
- ¹ See Connector grid below for additional information and/or requirements.

Lateral Bracing	Bracing Intervals	Comments
Top Edge (Lu)	Continuous	
Bottom Edge (Lu)	End Bearing Points	

Connector: Simpson Strong-Tie							
Support	Model	Seat Length	Top Fasteners	Face Fasteners	Member Fasteners	Accessories	
1 - Face Mount Hanger	LU26	1.50"	N/A	6-10dx1.5	4-10dx1.5		

- Refer to manufacturer notes and instructions for proper installation and use of all connectors.

Vertical Load	Location (Side)	Spacing	Dead (0.90)	Floor Live (1.00)	Snow (1.15)	Comments
1 - Uniform (PSF)	0 to 7' 9"	16"	12.0	60.0	25.0	Deck Load

Weyerhaeuser Notes
 Weyerhaeuser warrants that the sizing of its products will be in accordance with Weyerhaeuser product design criteria and published design values. Weyerhaeuser expressly disclaims any other warranties related to the software. Use of this software is not intended to circumvent the need for a design professional as determined by the authority having jurisdiction. The designer of record, builder or framer is responsible to assure that this calculation is compatible with the overall project. Accessories (Rim Board, Blocking Panels and Squash Blocks) are not designed by this software. Products manufactured at Weyerhaeuser facilities are third-party certified to sustainable forestry standards. Weyerhaeuser Engineered Lumber Products have been evaluated by ICC-ES under evaluation reports ESR-1153 and ESR-1387 and/or tested in accordance with applicable ASTM standards. For current code evaluation reports, Weyerhaeuser product literature and installation details refer to www.weyerhaeuser.com/woodproducts/document-library.
 The product application, input design loads, dimensions and support information have been provided by ForteWEB Software Operator

ForteWEB Software Operator	Job Notes
Harrison Kliegl L120 Engineering (425) 636-3313 hkliegl@l120engineering.com	



2nd Floor, 2J-4

1 piece(s) 2 x 8 DF No.2 @ 16" OC

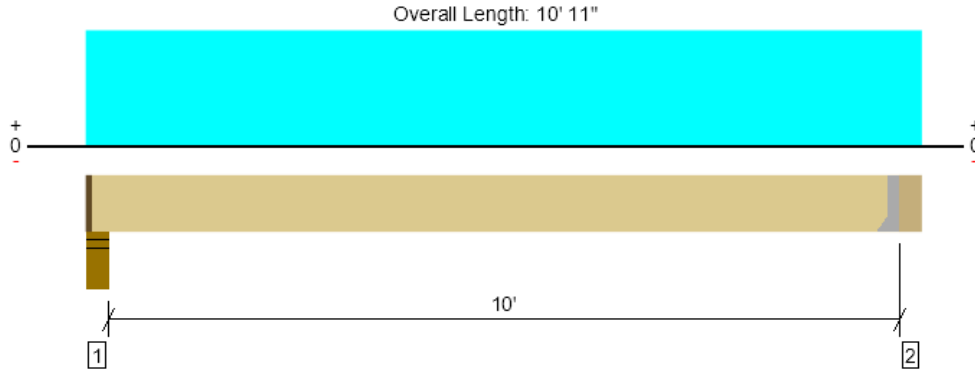

Drawing is Conceptual. All locations are measured from the outside face of left support (or left cantilever end). All dimensions are horizontal (typ.).

Design Results	Actual @ Location	Allowed	Result	LDF	Load: Combination (Pattern)
Member Reaction (lbs)	403 @ 10' 5 1/2"	1406 (1.50")	Passed (29%)	--	1.0 D + 1.0 L (All Spans)
Shear (lbs)	355 @ 9' 10 1/4"	1305	Passed (27%)	1.00	1.0 D + 1.0 L (All Spans)
Moment (Ft-lbs)	1017 @ 5' 5"	1360	Passed (75%)	1.00	1.0 D + 1.0 L (All Spans)
Live Load Defl. (in)	0.163 @ 5' 5"	0.252	Passed (L/743)	--	1.0 D + 1.0 L (All Spans)
Total Load Defl. (in)	0.244 @ 5' 5"	0.504	Passed (L/496)	--	1.0 D + 1.0 L (All Spans)
TJ-Pro™ Rating	N/A	N/A	N/A	--	N/A

Member Length : 10' 4"
 System : Floor
 Member Type : Joist
 Building Use : Residential
 Building Code : IBC 2021
 Design Methodology : ASD

- Deflection criteria: LL (L/480) and TL (L/240).
- A 15% increase in the moment capacity has been added to account for repetitive member usage.
- Applicable calculations are based on NDS.
- No composite action between deck and joist was considered in analysis.

Supports	Bearing Length			Loads to Supports (lbs)			Accessories
	Total	Available	Required	Dead	Floor Live	Factored	
1 - Stud wall - DF	5.50"	4.00"	1.50"	144	289	433	1 1/2" Rim Board
2 - Hanger on 7 1/4" DF beam	5.50"	Hanger ¹	1.50"	147	293	440	See note ¹

- Rim Board is assumed to carry all loads applied directly above it, bypassing the member being designed.
- At hanger supports, the Total Bearing dimension is equal to the width of the material that is supporting the hanger
- ¹ See Connector grid below for additional information and/or requirements.

Lateral Bracing	Bracing Intervals	Comments
Top Edge (Lu)	Continuous	
Bottom Edge (Lu)	End Bearing Points	

Connector: Simpson Strong-Tie

Support	Model	Seat Length	Top Fasteners	Face Fasteners	Member Fasteners	Accessories
2 - Face Mount Hanger	LU26	1.50"	N/A	6-10dx1.5	4-10dx1.5	

- Refer to manufacturer notes and instructions for proper installation and use of all connectors.

Vertical Load	Location (Side)	Spacing	Dead (0.90)	Floor Live (1.00)	Comments
1 - Uniform (PSF)	0 to 10' 11"	16"	20.0	40.0	Walk-in Shower Load

Weyerhaeuser Notes

Weyerhaeuser warrants that the sizing of its products will be in accordance with Weyerhaeuser product design criteria and published design values. Weyerhaeuser expressly disclaims any other warranties related to the software. Use of this software is not intended to circumvent the need for a design professional as determined by the authority having jurisdiction. The designer of record, builder or framer is responsible to assure that this calculation is compatible with the overall project. Accessories (Rim Board, Blocking Panels and Squash Blocks) are not designed by this software. Products manufactured at Weyerhaeuser facilities are third-party certified to sustainable forestry standards. Weyerhaeuser Engineered Lumber Products have been evaluated by ICC-ES under evaluation reports ESR-1153 and ESR-1387 and/or tested in accordance with applicable ASTM standards. For current code evaluation reports, Weyerhaeuser product literature and installation details refer to www.weyerhaeuser.com/woodproducts/document-library.

The product application, input design loads, dimensions and support information have been provided by ForteWEB Software Operator

ForteWEB Software Operator	Job Notes
Harrison Kliegl L120 Engineering (425) 636-3313 hkliegl@l120engineering.com	



8/23/2024 3:55:53 AM UTC
 ForteWEB v3.8, Engine: V8.4.1.24, Data: V8.1.6.3
 File Name: Granbois Residence

2nd Floor, 2J-5

1 piece(s) 11 7/8" TJI® 210 @ 19.2" OC

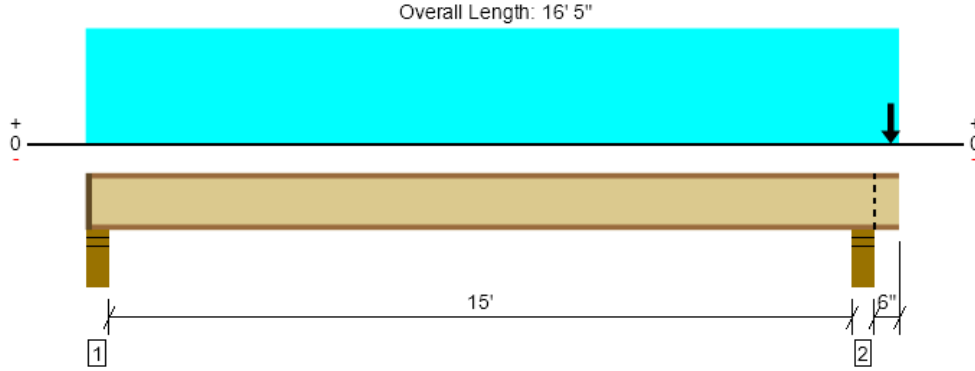

Drawing is Conceptual. All locations are measured from the outside face of left support (or left cantilever end). All dimensions are horizontal (typ.).

Design Results	Actual @ Location	Allowed	Result	LDF	Load: Combination (Pattern)
Member Reaction (lbs)	646 @ 4 1/2"	1460 (3.50")	Passed (44%)	1.00	1.0 D + 1.0 L (Alt Spans)
Shear (lbs)	619 @ 5 1/2"	1655	Passed (37%)	1.00	1.0 D + 1.0 L (Alt Spans)
Moment (Ft-lbs)	2351 @ 7' 10 11/16"	3795	Passed (62%)	1.00	1.0 D + 1.0 L (Alt Spans)
Live Load Defl. (in)	0.233 @ 8' 3/8"	0.383	Passed (L/787)	--	1.0 D + 1.0 L (Alt Spans)
Total Load Defl. (in)	0.292 @ 7' 11 13/16"	0.766	Passed (L/629)	--	1.0 D + 1.0 L (Alt Spans)
TJ-Pro™ Rating	43	40	Passed	--	--

Member Length : 16' 3 1/2"
 System : Floor
 Member Type : Joist
 Building Use : Residential
 Building Code : IBC 2021
 Design Methodology : ASD

- Deflection criteria: LL (L/480) and TL (L/240).
- Overhang deflection criteria: LL (2L/480) and TL (2L/240).
- Allowed moment does not reflect the adjustment for the beam stability factor.
- A structural analysis of the deck has not been performed.
- Deflection analysis is based on composite action with a single layer of 23/32" Weyerhaeuser Edge™ Panel (24" Span Rating) that is glued and nailed down.
- Additional considerations for the TJ-Pro™ Rating include: None.

Supports	Bearing Length			Loads to Supports (lbs)				Accessories
	Total	Available	Required	Dead	Floor Live	Snow	Factored	
1 - Stud wall - DF	5.50"	4.00"	1.75"	143	514	-11	657	1 1/2" Rim Board
2 - Stud wall - DF	5.50"	5.50"	3.50"	477	538	312	1114	Blocking

- Rim Board is assumed to carry all loads applied directly above it, bypassing the member being designed.
- Blocking Panels are assumed to carry no loads applied directly above them and the full load is applied to the member being designed.

Lateral Bracing	Bracing Intervals	Comments
Top Edge (Lu)	4' 9" o/c	
Bottom Edge (Lu)	8' 8" o/c	

- TJI joists are only analyzed using Maximum Allowable bracing solutions.
- Maximum allowable bracing intervals based on applied load.

Vertical Loads	Location	Spacing	Dead (0.90)	Floor Live (1.00)	Snow (1.15)	Comments
1 - Uniform (PSF)	0 to 16' 5"	19.2"	12.0	40.0	-	Floor Load
2 - Point (PLF)	16' 3"	19.2"	100.0	-	-	Wall Load Above
3 - Point (PLF)	16' 3"	19.2"	90.0	-	188.0	DL = 12 psf * 7.5 SL = 25 psf * 7.5

Weyerhaeuser Notes

Weyerhaeuser warrants that the sizing of its products will be in accordance with Weyerhaeuser product design criteria and published design values. Weyerhaeuser expressly disclaims any other warranties related to the software. Use of this software is not intended to circumvent the need for a design professional as determined by the authority having jurisdiction. The designer of record, builder or framer is responsible to assure that this calculation is compatible with the overall project. Accessories (Rim Board, Blocking Panels and Squash Blocks) are not designed by this software. Products manufactured at Weyerhaeuser facilities are third-party certified to sustainable forestry standards. Weyerhaeuser Engineered Lumber Products have been evaluated by ICC-ES under evaluation reports ESR-1153 and ESR-1387 and/or tested in accordance with applicable ASTM standards. For current code evaluation reports, Weyerhaeuser product literature and installation details refer to www.weyerhaeuser.com/woodproducts/document-library.

The product application, input design loads, dimensions and support information have been provided by ForteWEB Software Operator

ForteWEB Software Operator	Job Notes
Harrison Kliegl L120 Engineering (425) 636-3313 hkliegl@l120engineering.com	



8/23/2024 3:55:53 AM UTC
 ForteWEB v3.8, Engine: V8.4.1.24, Data: V8.1.6.3
 File Name: Granbois Residence

2nd Floor, 2J-6

1 piece(s) 11 7/8" TJI@ 210 @ 16" OC

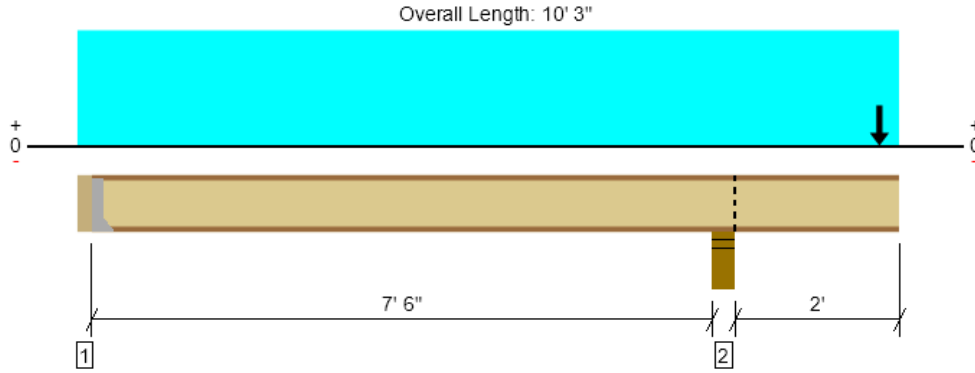

Drawing is Conceptual. All locations are measured from the outside face of left support (or left cantilever end). All dimensions are horizontal (typ.).

Design Results	Actual @ Location	Allowed	Result	LDF	Load: Combination (Pattern)
Member Reaction (lbs)	632 @ 8' 1/4"	2565 (5.25")	Passed (25%)	1.00	1.0 D + 1.0 L (All Spans)
Shear (lbs)	288 @ 8' 3"	1655	Passed (17%)	1.00	1.0 D + 1.0 L (All Spans)
Moment (Ft-lbs)	-468 @ 8' 1/4"	3795	Passed (12%)	1.00	1.0 D + 1.0 L (All Spans)
Live Load Defl. (in)	0.018 @ 4' 1 7/8"	0.193	Passed (L/999+)	--	1.0 D + 1.0 L (Alt Spans)
Total Load Defl. (in)	0.021 @ 10' 3"	0.223	Passed (2L/999+)	--	1.0 D + 0.75 L + 0.75 S (Alt Spans)
TJ-Pro™ Rating	65	40	Passed	--	--

Member Length : 9' 11 1/2"
 System : Floor
 Member Type : Joist
 Building Use : Residential
 Building Code : IBC 2021
 Design Methodology : ASD

- Deflection criteria: LL (L/480) and TL (L/240).
- Overhang deflection criteria: LL (2L/480) and TL (2L/240).
- Allowed moment does not reflect the adjustment for the beam stability factor.
- A structural analysis of the deck has not been performed.
- Deflection analysis is based on composite action with a single layer of 23/32" Weyerhaeuser Edge™ Panel (24" Span Rating) that is glued and nailed down.
- Additional considerations for the TJ-Pro™ Rating include: None.

Supports	Bearing Length			Loads to Supports (lbs)				Accessories
	Total	Available	Required	Dead	Floor Live	Snow	Factored	
1 - Hanger on 11 7/8" LVL beam	3.50"	Hanger ¹	1.75" / - ²	23	222/-2	-9	245	See note ¹
2 - Stud wall - DF	5.50"	5.50"	3.50"	290	342	42	632	Blocking

- Blocking Panels are assumed to carry no loads applied directly above them and the full load is applied to the member being designed.
- At hanger supports, the Total Bearing dimension is equal to the width of the material that is supporting the hanger
- ¹ See Connector grid below for additional information and/or requirements.
- ² Required Bearing Length / Required Bearing Length with Web Stiffeners

Lateral Bracing	Bracing Intervals	Comments
Top Edge (Lu)	8' 8" o/c	
Bottom Edge (Lu)	8' 8" o/c	

- TJI joists are only analyzed using Maximum Allowable bracing solutions.
- Maximum allowable bracing intervals based on applied load.

Connector: Simpson Strong-Tie						
Support	Model	Seat Length	Top Fasteners	Face Fasteners	Member Fasteners	Accessories
1 - Face Mount Hanger	IUS2.06/11.88	2.00"	N/A	10-10dx1.5	2-Strong-Grip	

- Refer to manufacturer notes and instructions for proper installation and use of all connectors.

Vertical Loads	Location	Spacing	Dead (0.90)	Floor Live (1.00)	Snow (1.15)	Comments
1 - Uniform (PSF)	0 to 10' 3"	16"	12.0	40.0	-	Floor Load
2 - Point (PLF)	10'	16"	100.0	-	-	Wall Load Above
3 - Point (PLF)	10'	16"	12.0	-	25.0	DL = 12 psf * 1 ft SL = 25 psf * 1 ft

Forteweb Software Operator	Job Notes
Harrison Kliegl L120 Engineering (425) 636-3313 hkliegl@l120engineering.com	



8/23/2024 3:55:53 AM UTC
 Forteweb v3.8, Engine: V8.4.1.24, Data: V8.1.6.3
 File Name: Granbois Residence

Weyerhaeuser Notes

Weyerhaeuser warrants that the sizing of its products will be in accordance with Weyerhaeuser product design criteria and published design values. Weyerhaeuser expressly disclaims any other warranties related to the software. Use of this software is not intended to circumvent the need for a design professional as determined by the authority having jurisdiction. The designer of record, builder or framer is responsible to assure that this calculation is compatible with the overall project. Accessories (Rim Board, Blocking Panels and Squash Blocks) are not designed by this software. Products manufactured at Weyerhaeuser facilities are third-party certified to sustainable forestry standards. Weyerhaeuser Engineered Lumber Products have been evaluated by ICC-ES under evaluation reports ESR-1153 and ESR-1387 and/or tested in accordance with applicable ASTM standards. For current code evaluation reports, Weyerhaeuser product literature and installation details refer to www.weyerhaeuser.com/woodproducts/document-library.

The product application, input design loads, dimensions and support information have been provided by ForteWEB Software Operator

ForteWEB Software Operator	Job Notes
Harrison Kliegl L120 Engineering (425) 636-3313 hkliegl@l120engineering.com	



2nd Floor, 2B-1 (Beam at the Master deck)
1 piece(s) 7" x 14" 2.2E Parallam® PSL

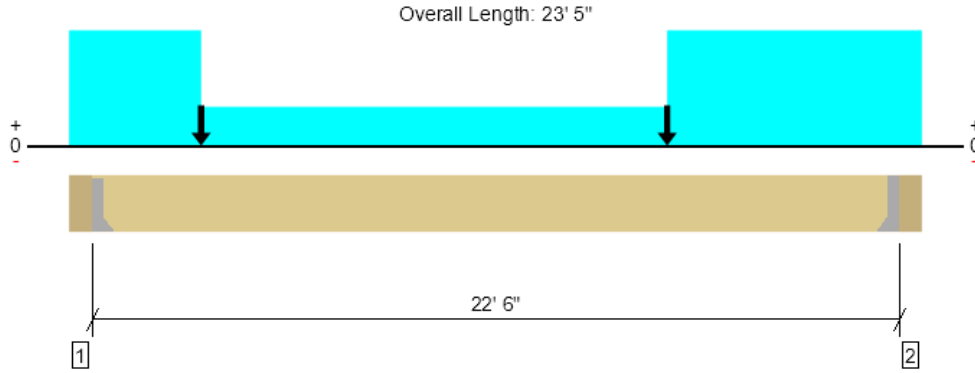

Drawing is Conceptual. All locations are measured from the outside face of left support (or left cantilever end). All dimensions are horizontal (typ.).

Design Results	Actual @ Location	Allowed	Result	LDF	Load: Combination (Pattern)
Member Reaction (lbs)	8496 @ 22' 11 1/2"	8496 (1.94")	Passed (100%)	--	1.0 D + 0.75 L + 0.75 S (All Spans)
Shear (lbs)	7539 @ 21' 9 1/2"	21789	Passed (35%)	1.15	1.0 D + 0.75 L + 0.75 S (All Spans)
Moment (Ft-lbs)	38160 @ 14' 9 1/8"	62472	Passed (61%)	1.15	1.0 D + 0.75 L + 0.75 S (All Spans)
Live Load Defl. (in)	0.513 @ 11' 10 1/4"	0.563	Passed (L/526)	--	1.0 D + 0.75 L + 0.75 S (All Spans)
Total Load Defl. (in)	1.056 @ 11' 11 7/8"	1.125	Passed (L/256)	--	1.0 D + 0.75 L + 0.75 S (All Spans)

Member Length : 22' 6"
 System : Floor
 Member Type : Flush Beam
 Building Use : Residential
 Building Code : IBC 2021
 Design Methodology : ASD

- Deflection criteria: LL (L/480) and TL (L/240).
- Allowed moment does not reflect the adjustment for the beam stability factor.
- Member should be side-loaded from both sides of the member or braced to prevent rotation.

Supports	Bearing Length			Loads to Supports (lbs)				Accessories
	Total	Available	Required	Dead	Floor Live	Snow	Factored	
1 - Hanger on 14" PSL beam	5.50"	Hanger ¹	1.88"	4724	2108	3053	8594	See note ¹
2 - Hanger on 14" PSL beam	5.50"	Hanger ¹	1.94"	5128	2108	2865	8858	See note ¹

- At hanger supports, the Total Bearing dimension is equal to the width of the material that is supporting the hanger
- ¹ See Connector grid below for additional information and/or requirements.

Lateral Bracing	Bracing Intervals	Comments
Top Edge (Lu)	22' 6" o/c	
Bottom Edge (Lu)	22' 6" o/c	

•Maximum allowable bracing intervals based on applied load.

Connector: Simpson Strong-Tie						
Support	Model	Seat Length	Top Fasteners	Face Fasteners	Member Fasteners	Accessories
1 - Face Mount Hanger	HGUS7.25/10	4.00"	N/A	46-16d	16-16d	
2 - Face Mount Hanger	HGUS7.25/10	4.00"	N/A	46-16d	16-16d	

• Refer to manufacturer notes and instructions for proper installation and use of all connectors.

Forteweb Software Operator	Job Notes
Harrison Kliegl L120 Engineering (425) 636-3313 hkliegl@l120engineering.com	



Vertical Loads	Location (Side)	Tributary Width	Dead (0.90)	Floor Live (1.00)	Snow (1.15)	Comments
0 - Self Weight (PLF)	5 1/2" to 22' 11 1/2"	N/A	30.6	--	--	
1 - Uniform (PSF)	0 to 23' 5" (Back)	3'	15.0	60.0	25.0	Deck Load
2 - Uniform (PLF)	0 to 3' 6" (Top)	N/A	460.0	-	125.0	DL = 12 psf * 5ft + 400 plf SL = 25 psf * 5
3 - Uniform (PLF)	16' 6" to 23' 5" (Top)	N/A	460.0	-	125.0	DL = 12 psf * 5ft + 400 plf SL = 25 psf * 5
4 - Point (lb)	3' 6" (Top)	N/A	1659	-	1430	Linked from: 2H-3 (Beam Over 2nd floor Slider), Support 1
5 - Point (lb)	16' 6" (Top)	N/A	1659	-	1430	Linked from: 2H-3 (Beam Over 2nd floor Slider), Support 2

• Side loads are assumed to not induce cross-grain tension.

Weyerhaeuser Notes

Weyerhaeuser warrants that the sizing of its products will be in accordance with Weyerhaeuser product design criteria and published design values. Weyerhaeuser expressly disclaims any other warranties related to the software. Use of this software is not intended to circumvent the need for a design professional as determined by the authority having jurisdiction. The designer of record, builder or framer is responsible to assure that this calculation is compatible with the overall project. Accessories (Rim Board, Blocking Panels and Squash Blocks) are not designed by this software. Products manufactured at Weyerhaeuser facilities are third-party certified to sustainable forestry standards. Weyerhaeuser Engineered Lumber Products have been evaluated by ICC-ES under evaluation reports ESR-1153 and ESR-1387 and/or tested in accordance with applicable ASTM standards. For current code evaluation reports, Weyerhaeuser product literature and installation details refer to www.weyerhaeuser.com/woodproducts/document-library.

The product application, input design loads, dimensions and support information have been provided by ForteWEB Software Operator

ForteWEB Software Operator	Job Notes
Harrison Kliegl L120 Engineering (425) 636-3313 hkliegl@l120engineering.com	



8/23/2024 3:55:53 AM UTC
ForteWEB v3.8, Engine: V8.4.1.24, Data: V8.1.6.3
File Name: Granbois Residence

2nd Floor, 2B-2 (Beam under interior Master slider door wall)
1 piece(s) 7" x 11 7/8" 2.2E Parallam® PSL

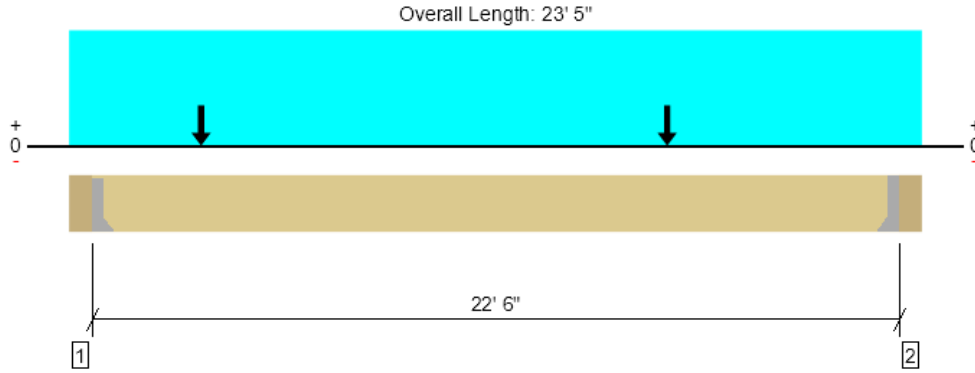

Drawing is Conceptual. All locations are measured from the outside face of left support (or left cantilever end). All dimensions are horizontal (typ.).

Design Results	Actual @ Location	Allowed	Result	LDF	Load: Combination (Pattern)
Member Reaction (lbs)	4306 @ 5 1/2"	6563 (1.50")	Passed (66%)	--	1.0 D + 0.75 L + 0.75 S (All Spans)
Shear (lbs)	3613 @ 1' 5 3/8"	16071	Passed (22%)	1.00	1.0 D + 1.0 L (All Spans)
Moment (Ft-lbs)	20121 @ 12' 3 7/16"	39805	Passed (51%)	1.00	1.0 D + 1.0 L (All Spans)
Live Load Defl. (in)	0.535 @ 11' 9 5/8"	0.563	Passed (L/504)	--	1.0 D + 0.75 L + 0.75 S (All Spans)
Total Load Defl. (in)	0.962 @ 11' 9 7/8"	1.125	Passed (L/281)	--	1.0 D + 0.75 L + 0.75 S (All Spans)

Member Length : 22' 6"
 System : Floor
 Member Type : Flush Beam
 Building Use : Residential
 Building Code : IBC 2021
 Design Methodology : ASD

- Deflection criteria: LL (L/480) and TL (L/240).
- Allowed moment does not reflect the adjustment for the beam stability factor.
- Member should be side-loaded from both sides of the member or braced to prevent rotation.

Supports	Bearing Length			Loads to Supports (lbs)				Accessories
	Total	Available	Required	Dead	Floor Live	Snow	Factored	
1 - Hanger on 11 7/8" PSL beam	5.50"	Hanger ¹	1.50"	1969	1990	1235	4388	See note ¹
2 - Hanger on 11 7/8" PSL beam	5.50"	Hanger ¹	1.50"	1684	1990	909	3859	See note ¹

- At hanger supports, the Total Bearing dimension is equal to the width of the material that is supporting the hanger
- ¹ See Connector grid below for additional information and/or requirements.

Lateral Bracing	Bracing Intervals	Comments
Top Edge (Lu)	22' 6" o/c	
Bottom Edge (Lu)	22' 6" o/c	

•Maximum allowable bracing intervals based on applied load.

Connector: Simpson Strong-Tie						
Support	Model	Seat Length	Top Fasteners	Face Fasteners	Member Fasteners	Accessories
1 - Face Mount Hanger	HHUS7.25/10	3.31"	N/A	30-10d	10-10d	
2 - Face Mount Hanger	HHUS7.25/10	3.31"	N/A	30-10d	10-10d	

• Refer to manufacturer notes and instructions for proper installation and use of all connectors.

Vertical Loads	Location (Side)	Tributary Width	Dead (0.90)	Floor Live (1.00)	Snow (1.15)	Comments
0 - Self Weight (PLF)	5 1/2" to 22' 11 1/2"	N/A	26.0	--	--	
1 - Uniform (PSF)	0 to 23' 5" (Front)	4' 3"	12.0	40.0	-	Floor Load
2 - Point (lb)	3' 6" (Top)	N/A	937	-	1072	Linked from: 2H-3 (Inside Beam Over 2nd floor Slider), Support 1
3 - Point (lb)	16' 6" (Top)	N/A	937	-	1072	Linked from: 2H-3 (Inside Beam Over 2nd floor Slider), Support 2

• Side loads are assumed to not induce cross-grain tension.

Forteweb Software Operator	Job Notes
Harrison Kliegl L120 Engineering (425) 636-3313 hkliegl@l120engineering.com	



Weyerhaeuser Notes

Weyerhaeuser warrants that the sizing of its products will be in accordance with Weyerhaeuser product design criteria and published design values. Weyerhaeuser expressly disclaims any other warranties related to the software. Use of this software is not intended to circumvent the need for a design professional as determined by the authority having jurisdiction. The designer of record, builder or framer is responsible to assure that this calculation is compatible with the overall project. Accessories (Rim Board, Blocking Panels and Squash Blocks) are not designed by this software. Products manufactured at Weyerhaeuser facilities are third-party certified to sustainable forestry standards. Weyerhaeuser Engineered Lumber Products have been evaluated by ICC-ES under evaluation reports ESR-1153 and ESR-1387 and/or tested in accordance with applicable ASTM standards. For current code evaluation reports, Weyerhaeuser product literature and installation details refer to www.weyerhaeuser.com/woodproducts/document-library.

The product application, input design loads, dimensions and support information have been provided by ForteWEB Software Operator

ForteWEB Software Operator	Job Notes
Harrison Kliegl L120 Engineering (425) 636-3313 hkliegl@l120engineering.com	



2nd Floor, 2B-2.1 (Beam directly under Master slider door)
1 piece(s) 7" x 14" 2.2E Parallam® PSL

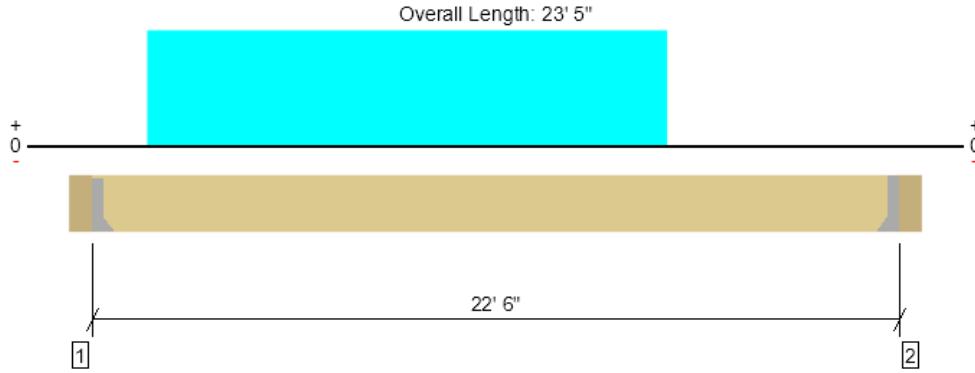

Drawing is Conceptual. All locations are measured from the outside face of left support (or left cantilever end). All dimensions are horizontal (typ.).

Design Results	Actual @ Location	Allowed	Result	LDF	Load: Combination (Pattern)
Member Reaction (lbs)	2111 @ 5 1/2"	6563 (1.50")	Passed (32%)	--	1.0 D (All Spans)
Shear (lbs)	2076 @ 1' 7 1/2"	17052	Passed (12%)	0.90	1.0 D (All Spans)
Moment (Ft-lbs)	12456 @ 10' 11 3/8"	48891	Passed (25%)	0.90	1.0 D (All Spans)
Live Load Defl. (in)	0.000 @ 5 1/2"	0.563	Passed (L/999+)	--	1.0 D (All Spans)
Total Load Defl. (in)	0.326 @ 11' 5 5/8"	1.125	Passed (L/828)	--	1.0 D (All Spans)

Member Length : 22' 6"
 System : Floor
 Member Type : Flush Beam
 Building Use : Residential
 Building Code : IBC 2021
 Design Methodology : ASD

- Deflection criteria: LL (L/480) and TL (L/240).
- Allowed moment does not reflect the adjustment for the beam stability factor.
- Member should be side-loaded from both sides of the member or braced to prevent rotation.

Supports	Bearing Length			Loads to Supports (lbs)		Accessories
	Total	Available	Required	Dead	Factored	
1 - Hanger on 14" PSL beam	5.50"	Hanger ¹	1.50"	2111	2111	See note ¹
2 - Hanger on 14" PSL beam	5.50"	Hanger ¹	1.50"	1478	1478	See note ¹

- At hanger supports, the Total Bearing dimension is equal to the width of the material that is supporting the hanger
- ¹ See Connector grid below for additional information and/or requirements.

Lateral Bracing	Bracing Intervals	Comments
Top Edge (Lu)	22' 6" o/c	
Bottom Edge (Lu)	22' 6" o/c	

- Maximum allowable bracing intervals based on applied load.

Connector: Simpson Strong-Tie							
Support	Model	Seat Length	Top Fasteners	Face Fasteners	Member Fasteners	Accessories	
1 - Face Mount Hanger	HU410-2	2.50"	N/A	18-16d	8-16d		
2 - Face Mount Hanger	HU410-2	2.50"	N/A	18-10dx1.5	8-10d		

- Refer to manufacturer notes and instructions for proper installation and use of all connectors.

Vertical Loads	Location (Side)	Tributary Width	Dead (0.90)	Comments
0 - Self Weight (PLF)	5 1/2" to 22' 11 1/2"	N/A	30.6	
1 - Uniform (PLF)	2' to 16' 6" (Top)	N/A	200.0	Slider Door above

- Side loads are assumed to not induce cross-grain tension.

Weyerhaeuser Notes
Weyerhaeuser warrants that the sizing of its products will be in accordance with Weyerhaeuser product design criteria and published design values. Weyerhaeuser expressly disclaims any other warranties related to the software. Use of this software is not intended to circumvent the need for a design professional as determined by the authority having jurisdiction. The designer of record, builder or framer is responsible to assure that this calculation is compatible with the overall project. Accessories (Rim Board, Blocking Panels and Squash Blocks) are not designed by this software. Products manufactured at Weyerhaeuser facilities are third-party certified to sustainable forestry standards. Weyerhaeuser Engineered Lumber Products have been evaluated by ICC-ES under evaluation reports ESR-1153 and ESR-1387 and/or tested in accordance with applicable ASTM standards. For current code evaluation reports, Weyerhaeuser product literature and installation details refer to www.weyerhaeuser.com/woodproducts/document-library .
The product application, input design loads, dimensions and support information have been provided by ForteWEB Software Operator

ForteWEB Software Operator	Job Notes
Harrison Kliegl L120 Engineering (425) 636-3313 hkliegl@l120engineering.com	



2nd Floor, 2B-3

1 piece(s) 5 1/4" x 11 7/8" 2.2E Parallam® PSL

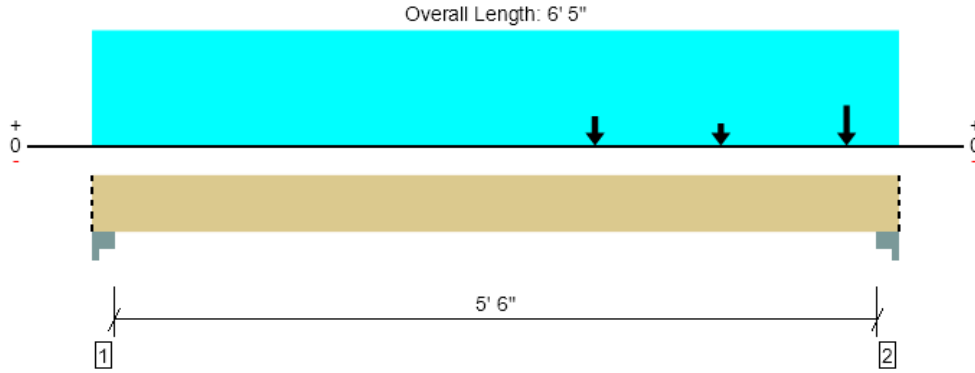

Drawing is Conceptual. All locations are measured from the outside face of left support (or left cantilever end). All dimensions are horizontal (typ.).

Design Results	Actual @ Location	Allowed	Result	LDF	Load: Combination (Pattern)
Member Reaction (lbs)	13348 @ 6' 1"	18047 (5.50")	Passed (74%)	--	1.0 D + 0.75 L + 0.75 S (All Spans)
Shear (lbs)	4340 @ 4' 11 5/8"	12053	Passed (36%)	1.00	1.0 D + 1.0 L (All Spans)
Moment (Ft-lbs)	7057 @ 4'	29854	Passed (24%)	1.00	1.0 D + 1.0 L (All Spans)
Live Load Defl. (in)	0.015 @ 4'	0.144	Passed (L/999+)	--	1.0 D + 0.75 L + 0.75 S (All Spans)
Total Load Defl. (in)	0.034 @ 4'	0.287	Passed (L/999+)	--	1.0 D + 0.75 L + 0.75 S (All Spans)

Member Length : 6' 5"
 System : Floor
 Member Type : Flush Beam
 Building Use : Residential
 Building Code : IBC 2021
 Design Methodology : ASD

- Deflection criteria: LL (L/480) and TL (L/240).
- Allowed moment does not reflect the adjustment for the beam stability factor.

Supports	Bearing Length			Loads to Supports (lbs)				Accessories
	Total	Available	Required	Dead	Floor Live	Snow	Factored	
1 - Column Cap - steel	5.50"	5.50"	1.50"	1225	892	447	2230	Blocking
2 - Column Cap - steel	5.50"	5.50"	4.07"	7807	3548	3841	13348	Blocking

• Blocking Panels are assumed to carry no loads applied directly above them and the full load is applied to the member being designed.

Lateral Bracing	Bracing Intervals	Comments
Top Edge (Lu)	6' 5" o/c	
Bottom Edge (Lu)	6' 5" o/c	

•Maximum allowable bracing intervals based on applied load.

Vertical Loads	Location (Side)	Tributary Width	Dead (0.90)	Floor Live (1.00)	Snow (1.15)	Comments
0 - Self Weight (PLF)	0 to 6' 5"	N/A	19.5	--	--	
1 - Uniform (PSF)	0 to 6' 5" (Front)	1' 4"	12.0	40.0	-	Floor Load
2 - Point (lb)	6' (Front)	N/A	4724	2108	3053	Linked from: 2B-1 (Beam at the Master deck), Support 1
3 - Point (lb)	4' (Front)	N/A	1969	1990	1235	Linked from: 2B-2 (Beam under the Master slider door), Support 1
4 - Point (lb)	5' (Front)	N/A	2111	-	-	Linked from: 2B-2.1 (Beam directly under Master slider door), Support 1

• Side loads are assumed to not induce cross-grain tension.

Weyerhaeuser Notes

Weyerhaeuser warrants that the sizing of its products will be in accordance with Weyerhaeuser product design criteria and published design values. Weyerhaeuser expressly disclaims any other warranties related to the software. Use of this software is not intended to circumvent the need for a design professional as determined by the authority having jurisdiction. The designer of record, builder or framer is responsible to assure that this calculation is compatible with the overall project. Accessories (Rim Board, Blocking Panels and Squash Blocks) are not designed by this software. Products manufactured at Weyerhaeuser facilities are third-party certified to sustainable forestry standards. Weyerhaeuser Engineered Lumber Products have been evaluated by ICC-ES under evaluation reports ESR-1153 and ESR-1387 and/or tested in accordance with applicable ASTM standards. For current code evaluation reports, Weyerhaeuser product literature and installation details refer to www.weyerhaeuser.com/woodproducts/document-library.

The product application, input design loads, dimensions and support information have been provided by ForteWEB Software Operator

ForteWEB Software Operator	Job Notes
Harrison Kliegl L120 Engineering (425) 636-3313 hkliegl@l120engineering.com	



8/23/2024 3:55:53 AM UTC
 ForteWEB v3.8, Engine: V8.4.1.24, Data: V8.1.6.3
 File Name: Granbois Residence

2nd Floor, 2B-4

1 piece(s) 7" x 16" 2.2E Parallam® PSL

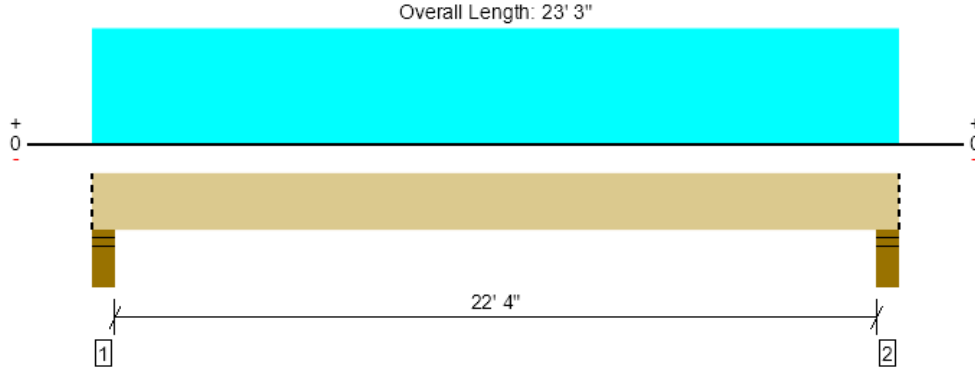

Drawing is Conceptual. All locations are measured from the outside face of left support (or left cantilever end). All dimensions are horizontal (typ.).

Design Results	Actual @ Location	Allowed	Result	LDF	Load: Combination (Pattern)
Member Reaction (lbs)	6603 @ 4"	15593 (5.50")	Passed (42%)	--	1.0 D + 1.0 L (All Spans)
Shear (lbs)	5585 @ 1' 9 1/2"	21653	Passed (26%)	1.00	1.0 D + 1.0 L (All Spans)
Moment (Ft-lbs)	36210 @ 11' 7 1/2"	69909	Passed (52%)	1.00	1.0 D + 1.0 L (All Spans)
Live Load Defl. (in)	0.481 @ 11' 7 1/2"	0.565	Passed (L/564)	--	1.0 D + 1.0 L (All Spans)
Total Load Defl. (in)	0.666 @ 11' 7 1/2"	1.129	Passed (L/407)	--	1.0 D + 1.0 L (All Spans)

Member Length : 23' 3"
 System : Floor
 Member Type : Flush Beam
 Building Use : Residential
 Building Code : IBC 2021
 Design Methodology : ASD

- Deflection criteria: LL (L/480) and TL (L/240).
- Allowed moment does not reflect the adjustment for the beam stability factor.
- Member should be side-loaded from both sides of the member or braced to prevent rotation.

Supports	Bearing Length			Loads to Supports (lbs)			Accessories
	Total	Available	Required	Dead	Floor Live	Factored	
1 - Stud wall - HF	5.50"	5.50"	2.33"	1837	4766	6603	Blocking
2 - Stud wall - HF	5.50"	5.50"	2.33"	1837	4766	6603	Blocking

• Blocking Panels are assumed to carry no loads applied directly above them and the full load is applied to the member being designed.

Lateral Bracing	Bracing Intervals	Comments
Top Edge (Lu)	23' 3" o/c	
Bottom Edge (Lu)	23' 3" o/c	

•Maximum allowable bracing intervals based on applied load.

Vertical Loads	Location (Side)	Tributary Width	Dead (0.90)	Floor Live (1.00)	Comments
0 - Self Weight (PLF)	0 to 23' 3"	N/A	35.0	--	
1 - Uniform (PSF)	0 to 23' 3" (Front)	10' 3"	12.0	40.0	Floor Load

• Side loads are assumed to not induce cross-grain tension.

Weyerhaeuser Notes

Weyerhaeuser warrants that the sizing of its products will be in accordance with Weyerhaeuser product design criteria and published design values. Weyerhaeuser expressly disclaims any other warranties related to the software. Use of this software is not intended to circumvent the need for a design professional as determined by the authority having jurisdiction. The designer of record, builder or framer is responsible to assure that this calculation is compatible with the overall project. Accessories (Rim Board, Blocking Panels and Squash Blocks) are not designed by this software. Products manufactured at Weyerhaeuser facilities are third-party certified to sustainable forestry standards. Weyerhaeuser Engineered Lumber Products have been evaluated by ICC-ES under evaluation reports ESR-1153 and ESR-1387 and/or tested in accordance with applicable ASTM standards. For current code evaluation reports, Weyerhaeuser product literature and installation details refer to www.weyerhaeuser.com/woodproducts/document-library.

The product application, input design loads, dimensions and support information have been provided by ForteWEB Software Operator

ForteWEB Software Operator	Job Notes
Harrison Kliegl L120 Engineering (425) 636-3313 hkliegl@l120engineering.com	



8/23/2024 3:55:53 AM UTC
 ForteWEB v3.8, Engine: V8.4.1.24, Data: V8.1.6.3
 File Name: Granbois Residence

2nd Floor, 2B-4 (Steel Beam Opt)
1 piece(s) W10X33 (A992) ASTM Steel

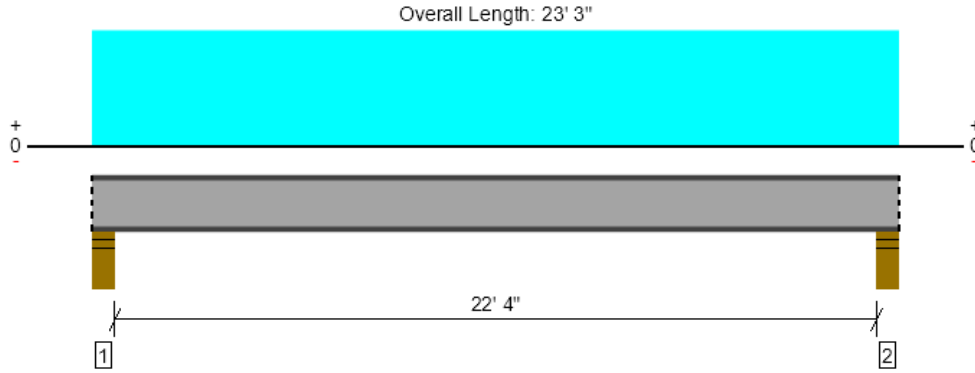

Drawing is Conceptual. All locations are measured from the outside face of left support (or left cantilever end). All dimensions are horizontal (typ.).

Design Results	Actual @ Location	Allowed	Result	LDF	Load: Combination (Pattern)
Member Reaction (lbs)	6580 @ 4"	17731 (5.50")	Passed (37%)	--	1.0 D + 1.0 L (All Spans)
Shear (lbs)	6320 @ 5 1/2"	56434	Passed (11%)	--	1.0 D + 1.0 L (All Spans)
Moment (Ft-lbs)	36083 @ 11' 7 1/2"	58189	Passed (62%)	--	1.0 D + 1.0 L (All Spans)
Live Load Defl. (in)	0.484 @ 11' 7 1/2"	0.565	Passed (L/560)	--	1.0 D + 1.0 L (All Spans)
Total Load Defl. (in)	0.668 @ 11' 7 1/2"	1.129	Passed (L/406)	--	1.0 D + 1.0 L (All Spans)

Member Length : 23' 3"
 System : Floor
 Member Type : Flush Beam
 Building Use : Residential
 Building Code : IBC 2021
 Design Methodology : ASD

- Deflection criteria: LL (L/480) and TL (L/240).
- Applicable calculations are based on ANSI/AISC 360-16.
- A lateral-torsional buckling factor (C_b) of 1.0 has been assumed.

Supports	Bearing Length			Loads to Supports (lbs)			Accessories
	Total	Available	Required	Dead	Floor Live	Factored	
1 - Stud wall - HF	5.50"	5.50"	5.50"	1814	4766	6580	Blocking
2 - Stud wall - HF	5.50"	5.50"	5.50"	1814	4766	6580	Blocking

• Blocking Panels are assumed to carry no loads applied directly above them and the full load is applied to the member being designed.

Lateral Bracing	Bracing Intervals	Comments
Top Edge (Lu)	End Bearing Points	
Bottom Edge (Lu)	End Bearing Points	

Vertical Loads	Location (Side)	Tributary Width	Dead (0.90)	Floor Live (1.00)	Comments
0 - Self Weight (PLF)	0 to 23' 3"	N/A	33.0	--	
1 - Uniform (PSF)	0 to 23' 3" (Front)	10' 3"	12.0	40.0	Floor Load

• Side loads are assumed to not induce cross-grain tension.

Weyerhaeuser Notes

Weyerhaeuser warrants that the sizing of its products will be in accordance with Weyerhaeuser product design criteria and published design values. Weyerhaeuser expressly disclaims any other warranties related to the software. Use of this software is not intended to circumvent the need for a design professional as determined by the authority having jurisdiction. The designer of record, builder or framer is responsible to assure that this calculation is compatible with the overall project. Accessories (Rim Board, Blocking Panels and Squash Blocks) are not designed by this software. Products manufactured at Weyerhaeuser facilities are third-party certified to sustainable forestry standards. Weyerhaeuser Engineered Lumber Products have been evaluated by ICC-ES under evaluation reports ESR-1153 and ESR-1387 and/or tested in accordance with applicable ASTM standards. For current code evaluation reports, Weyerhaeuser product literature and installation details refer to www.weyerhaeuser.com/woodproducts/document-library.

The product application, input design loads, dimensions and support information have been provided by ForteWEB Software Operator

ForteWEB Software Operator	Job Notes
Harrison Kliegl L120 Engineering (425) 636-3313 hkliegl@l120engineering.com	



8/23/2024 3:55:53 AM UTC
 ForteWEB v3.8, Engine: V8.4.1.24, Data: V8.1.6.3
 File Name: Granbois Residence

2nd Floor, 2B-5

1 piece(s) 7" x 11 1/4" 2.2E Parallam® PSL

Overall Length: 14' 5"

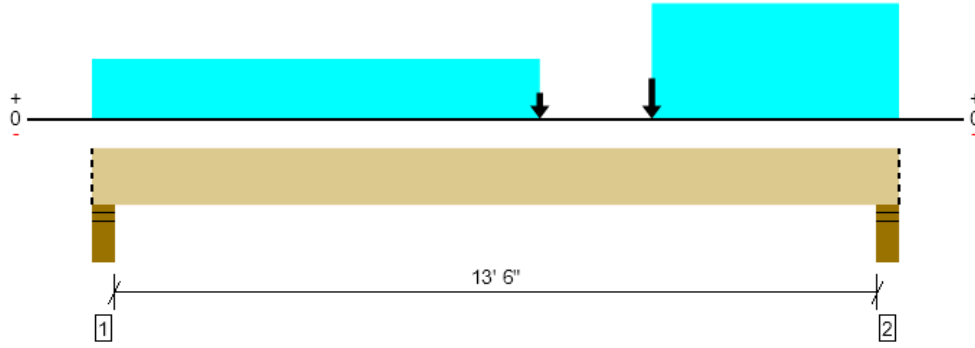

Drawing is Conceptual. All locations are measured from the outside face of left support (or left cantilever end). All dimensions are horizontal (typ.).

Design Results	Actual @ Location	Allowed	Result	LDF	Load: Combination (Pattern)
Member Reaction (lbs)	8946 @ 14' 1"	15593 (5.50")	Passed (57%)	--	1.0 D + 0.75 L + 0.75 S (All Spans)
Shear (lbs)	8801 @ 13' 1/4"	17509	Passed (50%)	1.15	1.0 D + 0.75 L + 0.75 S (All Spans)
Moment (Ft-lbs)	35526 @ 10'	41331	Passed (86%)	1.15	1.0 D + 0.75 L + 0.75 S (All Spans)
Live Load Defl. (in)	0.296 @ 8'	0.344	Passed (L/558)	--	1.0 D + 0.75 L + 0.75 S (All Spans)
Total Load Defl. (in)	0.628 @ 8'	0.688	Passed (L/263)	--	1.0 D + 0.75 L + 0.75 S (All Spans)

Member Length : 14' 5"
 System : Floor
 Member Type : Flush Beam
 Building Use : Residential
 Building Code : IBC 2021
 Design Methodology : ASD

- Deflection criteria: LL (L/480) and TL (L/240).
- Allowed moment does not reflect the adjustment for the beam stability factor.
- Member should be side-loaded from both sides of the member or braced to prevent rotation.

Supports	Bearing Length			Loads to Supports (lbs)				Accessories
	Total	Available	Required	Dead	Floor Live	Snow	Factored	
1 - Stud wall - HF	5.50"	5.50"	1.70"	2525	1777	1268	4809	Blocking
2 - Stud wall - HF	5.50"	5.50"	3.16"	4804	2906	2616	8946	Blocking

• Blocking Panels are assumed to carry no loads applied directly above them and the full load is applied to the member being designed.

Lateral Bracing	Bracing Intervals	Comments
Top Edge (Lu)	14' 5" o/c	
Bottom Edge (Lu)	14' 5" o/c	

•Maximum allowable bracing intervals based on applied load.

Vertical Loads	Location (Side)	Tributary Width	Dead (0.90)	Floor Live (1.00)	Snow (1.15)	Comments
0 - Self Weight (PLF)	0 to 14' 5"	N/A	24.6	--	--	
1 - Uniform (PSF)	0 to 8' (Front)	1'	12.0	40.0	-	Floor Load
2 - Uniform (PSF)	10' to 14' 5" (Front)	1'	15.0	60.0	25.0	Deck Load
3 - Point (lb)	10' (Front)	N/A	5128	2108	2865	Linked from: 2B-1 (Beam at the Master deck), Support 2
4 - Point (lb)	8' (Front)	N/A	1684	1990	909	Linked from: 2B-2 (Beam under the Master slider door), Support 2

• Side loads are assumed to not induce cross-grain tension.

Weyerhaeuser Notes

Weyerhaeuser warrants that the sizing of its products will be in accordance with Weyerhaeuser product design criteria and published design values. Weyerhaeuser expressly disclaims any other warranties related to the software. Use of this software is not intended to circumvent the need for a design professional as determined by the authority having jurisdiction. The designer of record, builder or framer is responsible to assure that this calculation is compatible with the overall project. Accessories (Rim Board, Blocking Panels and Squash Blocks) are not designed by this software. Products manufactured at Weyerhaeuser facilities are third-party certified to sustainable forestry standards. Weyerhaeuser Engineered Lumber Products have been evaluated by ICC-ES under evaluation reports ESR-1153 and ESR-1387 and/or tested in accordance with applicable ASTM standards. For current code evaluation reports, Weyerhaeuser product literature and installation details refer to www.weyerhaeuser.com/woodproducts/document-library.

The product application, input design loads, dimensions and support information have been provided by ForteWEB Software Operator

ForteWEB Software Operator	Job Notes
Harrison Kliegl L120 Engineering (425) 636-3313 hkliegl@l120engineering.com	



8/23/2024 3:55:53 AM UTC
 ForteWEB v3.8, Engine: V8.4.1.24, Data: V8.1.6.3
 File Name: Granbois Residence

2nd Floor, 2B-6

1 piece(s) 3 1/2" x 11 7/8" 2.2E Parallam® PSL

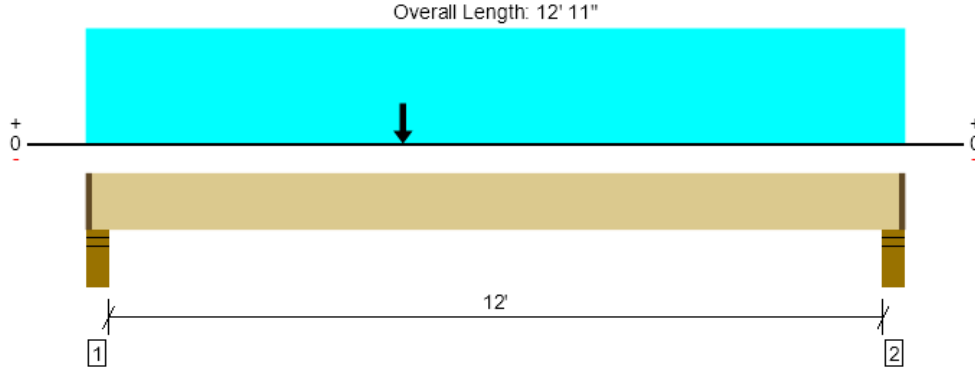

Drawing is Conceptual. All locations are measured from the outside face of left support (or left cantilever end). All dimensions are horizontal (typ.).

Design Results	Actual @ Location	Allowed	Result	LDF	Load: Combination (Pattern)
Member Reaction (lbs)	4913 @ 4"	5670 (4.00")	Passed (87%)	--	1.0 D + 0.525 E + 0.75 L + 0.75 S (All Spans)
Shear (lbs)	2973 @ 1' 5 3/8"	8035	Passed (37%)	1.00	1.0 D + 1.0 L (All Spans)
Moment (Ft-lbs)	11129 @ 6' 5 1/2"	19902	Passed (56%)	1.00	1.0 D + 1.0 L (All Spans)
Live Load Defl. (in)	0.190 @ 6' 5 1/2"	0.306	Passed (L/775)	--	1.0 D + 0.75 L + 0.75 S (All Spans)
Total Load Defl. (in)	0.342 @ 6' 5 1/2"	0.613	Passed (L/430)	--	1.0 D + 0.75 L + 0.75 S (All Spans)

Member Length : 12' 8"
 System : Floor
 Member Type : Flush Beam
 Building Use : Residential
 Building Code : IBC 2021
 Design Methodology : ASD

- Deflection criteria: LL (L/480) and TL (L/240).
- Allowed moment does not reflect the adjustment for the beam stability factor.

Supports	Bearing Length			Loads to Supports (lbs)					Accessories
	Total	Available	Required	Dead	Floor Live	Snow	Seismic	Factored	
1 - Stud wall - HF	5.50"	4.00"	3.47"	1893	1938	1211	1408/-1408	4993	1 1/2" Rim Board
2 - Stud wall - HF	5.50"	4.00"	3.27"	1893	1938	1211	867/-867	4709	1 1/2" Rim Board

• Rim Board is assumed to carry all loads applied directly above it, bypassing the member being designed.

Lateral Bracing	Bracing Intervals	Comments
Top Edge (Lu)	12' 8" o/c	
Bottom Edge (Lu)	12' 8" o/c	

•Maximum allowable bracing intervals based on applied load.

Vertical Loads	Location (Side)	Tributary Width	Dead (0.90)	Floor Live (1.00)	Snow (1.15)	Seismic (1.60)	Comments
0 - Self Weight (PLF)	1 1/2" to 12' 9 1/2"	N/A	13.0	--	--	--	
1 - Uniform (PSF)	0 to 12' 11" (Front)	7' 6"	12.0	40.0	-	-	Floor Load
2 - Uniform (PLF)	0 to 12' 11" (Top)	N/A	100.0	-	-	-	Wall Load Above
3 - Uniform (PSF)	0 to 12' 11" (Top)	7' 6"	12.0	-	25.0	-	Roof Load Above
4 - Point (lb)	5' (Top)	N/A	-	-	-	2275	EQ = 910lb * 2.5

• Side loads are assumed to not induce cross-grain tension.

Weyerhaeuser Notes
 Weyerhaeuser warrants that the sizing of its products will be in accordance with Weyerhaeuser product design criteria and published design values. Weyerhaeuser expressly disclaims any other warranties related to the software. Use of this software is not intended to circumvent the need for a design professional as determined by the authority having jurisdiction. The designer of record, builder or framer is responsible to assure that this calculation is compatible with the overall project. Accessories (Rim Board, Blocking Panels and Squash Blocks) are not designed by this software. Products manufactured at Weyerhaeuser facilities are third-party certified to sustainable forestry standards. Weyerhaeuser Engineered Lumber Products have been evaluated by ICC-ES under evaluation reports ESR-1153 and ESR-1387 and/or tested in accordance with applicable ASTM standards. For current code evaluation reports, Weyerhaeuser product literature and installation details refer to www.weyerhaeuser.com/woodproducts/document-library.
 The product application, input design loads, dimensions and support information have been provided by ForteWEB Software Operator

ForteWEB Software Operator	Job Notes
Harrison Kliegl L120 Engineering (425) 636-3313 hkliegl@l120engineering.com	



2nd Floor, 2B-7

1 piece(s) 1 3/4" x 11 7/8" 2.0E Microllam® LVL

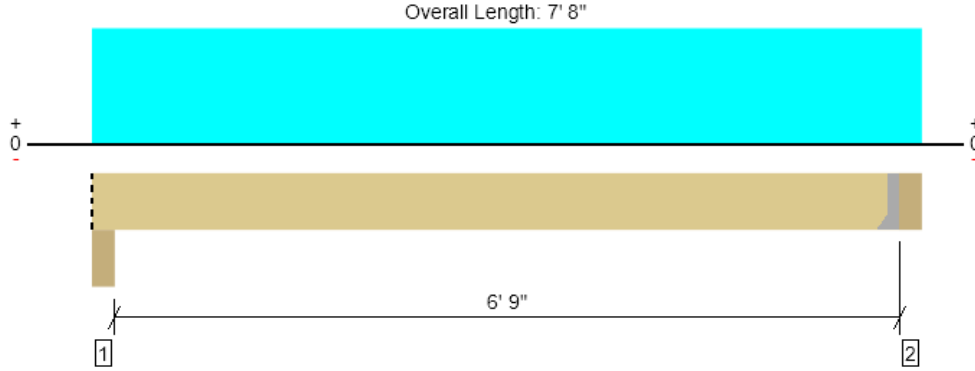

Drawing is Conceptual. All locations are measured from the outside face of left support (or left cantilever end). All dimensions are horizontal (typ.).

Design Results	Actual @ Location	Allowed	Result	LDF	Load: Combination (Pattern)
Member Reaction (lbs)	1533 @ 7' 2 1/2"	1969 (1.50")	Passed (78%)	--	1.0 D + 1.0 L (All Spans)
Shear (lbs)	1092 @ 6' 2 5/8"	3948	Passed (28%)	1.00	1.0 D + 1.0 L (All Spans)
Moment (Ft-lbs)	2635 @ 3' 9 1/4"	8924	Passed (30%)	1.00	1.0 D + 1.0 L (All Spans)
Live Load Defl. (in)	0.043 @ 3' 9 1/4"	0.172	Passed (L/999+)	--	1.0 D + 1.0 L (All Spans)
Total Load Defl. (in)	0.061 @ 3' 9 1/4"	0.344	Passed (L/999+)	--	1.0 D + 1.0 L (All Spans)

Member Length : 7' 2 1/2"
 System : Floor
 Member Type : Flush Beam
 Building Use : Residential
 Building Code : IBC 2021
 Design Methodology : ASD

- Deflection criteria: LL (L/480) and TL (L/240).
- Allowed moment does not reflect the adjustment for the beam stability factor.

Supports	Bearing Length			Loads to Supports (lbs)			Accessories
	Total	Available	Required	Dead	Floor Live	Factored	
1 - Beam - GLB	5.50"	5.50"	1.50"	475	1207	1682	Blocking
2 - Hanger on 11 7/8" PSL beam	5.50"	Hanger ¹	1.50"	488	1247	1735	See note ¹

- Blocking Panels are assumed to carry no loads applied directly above them and the full load is applied to the member being designed.
- At hanger supports, the Total Bearing dimension is equal to the width of the material that is supporting the hanger
- ¹ See Connector grid below for additional information and/or requirements.

Lateral Bracing	Bracing Intervals	Comments
Top Edge (Lu)	7' 3" o/c	
Bottom Edge (Lu)	7' 3" o/c	

- Maximum allowable bracing intervals based on applied load.

Connector: Simpson Strong-Tie

Support	Model	Seat Length	Top Fasteners	Face Fasteners	Member Fasteners	Accessories
2 - Face Mount Hanger	U14	2.00"	N/A	14-10d	6-10dx1.5	

- Refer to manufacturer notes and instructions for proper installation and use of all connectors.

Vertical Loads	Location (Side)	Tributary Width	Dead (0.90)	Floor Live (1.00)	Comments
0 - Self Weight (PLF)	0 to 7' 2 1/2"	N/A	6.1	--	
1 - Uniform (PSF)	0 to 7' 8" (Front)	8'	15.0	40.0	Floor Load

- Side loads are assumed to not induce cross-grain tension.

Weyerhaeuser Notes

Weyerhaeuser warrants that the sizing of its products will be in accordance with Weyerhaeuser product design criteria and published design values. Weyerhaeuser expressly disclaims any other warranties related to the software. Use of this software is not intended to circumvent the need for a design professional as determined by the authority having jurisdiction. The designer of record, builder or framer is responsible to assure that this calculation is compatible with the overall project. Accessories (Rim Board, Blocking Panels and Squash Blocks) are not designed by this software. Products manufactured at Weyerhaeuser facilities are third-party certified to sustainable forestry standards. Weyerhaeuser Engineered Lumber Products have been evaluated by ICC-ES under evaluation reports ESR-1153 and ESR-1387 and/or tested in accordance with applicable ASTM standards. For current code evaluation reports, Weyerhaeuser product literature and installation details refer to www.woyherhaeuser.com/woodproducts/document-library.

The product application, input design loads, dimensions and support information have been provided by ForteWEB Software Operator

ForteWEB Software Operator	Job Notes
Harrison Kliegl L120 Engineering (425) 636-3313 hkliegl@l120engineering.com	



8/23/2024 3:55:53 AM UTC
 ForteWEB v3.8, Engine: V8.4.1.24, Data: V8.1.6.3
 File Name: Granbois Residence

2nd Floor, 2B-8

2 piece(s) 1 3/4" x 11 7/8" 2.0E Microllam® LVL

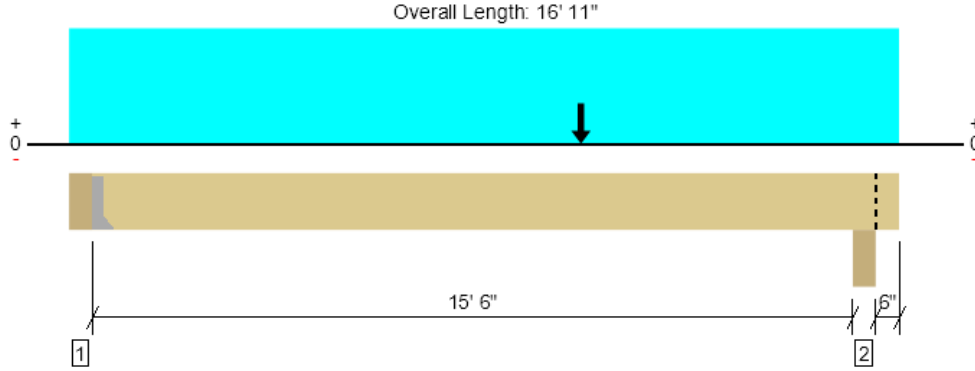

Drawing is Conceptual. All locations are measured from the outside face of left support (or left cantilever end). All dimensions are horizontal (typ.).

Design Results	Actual @ Location	Allowed	Result	LDF	Load: Combination (Pattern)
Member Reaction (lbs)	1399 @ 5 1/2"	3938 (1.50")	Passed (36%)	--	1.0 D + 1.0 L (Alt Spans)
Shear (lbs)	1711 @ 14' 11 5/8"	7897	Passed (22%)	1.00	1.0 D + 1.0 L (All Spans)
Moment (Ft-lbs)	9158 @ 10' 3"	17848	Passed (51%)	1.00	1.0 D + 1.0 L (Alt Spans)
Live Load Defl. (in)	0.265 @ 8' 8 1/4"	0.393	Passed (L/712)	--	1.0 D + 1.0 L (Alt Spans)
Total Load Defl. (in)	0.385 @ 8' 8 1/16"	0.786	Passed (L/490)	--	1.0 D + 1.0 L (Alt Spans)

Member Length : 16' 5 1/2"
 System : Floor
 Member Type : Flush Beam
 Building Use : Residential
 Building Code : IBC 2021
 Design Methodology : ASD

- Deflection criteria: LL (L/480) and TL (L/240).
- Overhang deflection criteria: LL (2L/480) and TL (2L/240).
- Allowed moment does not reflect the adjustment for the beam stability factor.

Supports	Bearing Length			Loads to Supports (lbs)			Accessories
	Total	Available	Required	Dead	Floor Live	Factored	
1 - Hanger on 11 7/8" PSL beam	5.50"	Hanger ¹	1.50"	466	970	1436	See note ¹
2 - Beam - HF	5.50"	5.50"	1.50"	602	1293	1895	Blocking

- Blocking Panels are assumed to carry no loads applied directly above them and the full load is applied to the member being designed.
- At hanger supports, the Total Bearing dimension is equal to the width of the material that is supporting the hanger
- ¹ See Connector grid below for additional information and/or requirements.

Lateral Bracing	Bracing Intervals	Comments
Top Edge (Lu)	16' 1" o/c	
Bottom Edge (Lu)	16' 6" o/c	

- Maximum allowable bracing intervals based on applied load.

Connector: Simpson Strong-Tie

Support	Model	Seat Length	Top Fasteners	Face Fasteners	Member Fasteners	Accessories
1 - Face Mount Hanger	LUS410	2.00"	N/A	8-10d	6-10d	

- Refer to manufacturer notes and instructions for proper installation and use of all connectors.

Vertical Loads	Location (Side)	Tributary Width	Dead (0.90)	Floor Live (1.00)	Comments
0 - Self Weight (PLF)	5 1/2" to 16' 11"	N/A	12.1	--	
1 - Uniform (PSF)	0 to 16' 11" (Front)	1' 6"	15.0	40.0	Floor Load
2 - Point (lb)	10' 3" (Front)	N/A	488	1247	Linked from: 2B-7, Support 2

- Side loads are assumed to not induce cross-grain tension.

Weyerhaeuser Notes

Weyerhaeuser warrants that the sizing of its products will be in accordance with Weyerhaeuser product design criteria and published design values. Weyerhaeuser expressly disclaims any other warranties related to the software. Use of this software is not intended to circumvent the need for a design professional as determined by the authority having jurisdiction. The designer of record, builder or framer is responsible to assure that this calculation is compatible with the overall project. Accessories (Rim Board, Blocking Panels and Squash Blocks) are not designed by this software. Products manufactured at Weyerhaeuser facilities are third-party certified to sustainable forestry standards. Weyerhaeuser Engineered Lumber Products have been evaluated by ICC-ES under evaluation reports ESR-1153 and ESR-1387 and/or tested in accordance with applicable ASTM standards. For current code evaluation reports, Weyerhaeuser product literature and installation details refer to www.woyherhaeuser.com/woodproducts/document-library.

The product application, input design loads, dimensions and support information have been provided by ForteWEB Software Operator

ForteWEB Software Operator	Job Notes
Harrison Kliegl L120 Engineering (425) 636-3313 hkliegl@l120engineering.com	



8/23/2024 3:55:53 AM UTC
 ForteWEB v3.8, Engine: V8.4.1.24, Data: V8.1.6.3
 File Name: Granbois Residence

2nd Floor, 2B-9

1 piece(s) 5 1/2" x 9" 24F-V4 DF Glulam

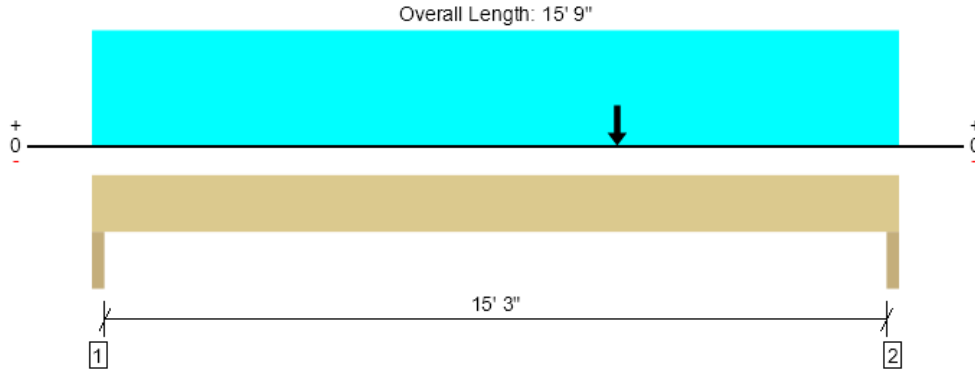

Drawing is Conceptual. All locations are measured from the outside face of left support (or left cantilever end). All dimensions are horizontal (typ.).

Design Results	Actual @ Location	Allowed	Result	LDF	Load: Combination (Pattern)
Member Reaction (lbs)	2600 @ 15' 7 1/2"	10725 (3.00")	Passed (24%)	--	1.0 D + 0.75 L + 0.75 S (All Spans)
Shear (lbs)	2392 @ 14' 9"	8745	Passed (27%)	1.00	1.0 D + 1.0 L (All Spans)
Pos Moment (Ft-lbs)	11024 @ 10' 3"	14624	Passed (75%)	1.00	1.0 D + 1.0 L (All Spans)
Live Load Defl. (in)	0.323 @ 8' 4 1/16"	0.517	Passed (L/576)	--	1.0 D + 1.0 L (All Spans)
Total Load Defl. (in)	0.735 @ 8' 1 1/4"	0.775	Passed (L/253)	--	1.0 D + 0.75 L + 0.75 S (All Spans)

Member Length : 15' 9"
 System : Floor
 Member Type : Drop Beam
 Building Use : Residential
 Building Code : IBC 2021
 Design Methodology : ASD

- Deflection criteria: LL (L/360) and TL (L/240).
- A 1.5% decrease in the moment capacity has been added to account for lateral stability.
- Critical positive moment adjusted by a volume/size factor of 1.00 that was calculated using length L = 15' 6".
- The effects of positive or negative camber have not been accounted for when calculating deflection.
- The specified glulam is assumed to have its strong laminations at the bottom of the beam. Install with proper side up as indicated by the manufacturer.
- Applicable calculations are based on NDS.

Supports	Bearing Length			Loads to Supports (lbs)				Accessories
	Total	Available	Required	Dead	Floor Live	Snow	Factored	
1 - Trimmer - HF	3.00"	3.00"	1.50"	1331	734	394	2177	None
2 - Trimmer - HF	3.00"	3.00"	1.50"	1477	1103	394	2600	None

Lateral Bracing	Bracing Intervals	Comments
Top Edge (Lu)	End Bearing Points	
Bottom Edge (Lu)	End Bearing Points	

Vertical Loads	Location (Side)	Tributary Width	Dead (0.90)	Floor Live (1.00)	Snow (1.15)	Comments
0 - Self Weight (PLF)	0 to 15' 9"	N/A	12.0	--	--	
1 - Uniform (PSF)	0 to 15' 9" (Front)	1'	12.0	40.0	-	Default Load
2 - Uniform (PLF)	0 to 15' 9" (Top)	N/A	100.0	-	-	Wall Load Above
3 - Uniform (PSF)	0 to 15' 9" (Top)	2'	12.0	-	25.0	Rood Load Above
4 - Point (lb)	10' 3" (Front)	N/A	475	1207	-	Linked from: 2B-7, Support 1

- Side loads are assumed to not induce cross-grain tension.

Weyerhaeuser Notes

Weyerhaeuser warrants that the sizing of its products will be in accordance with Weyerhaeuser product design criteria and published design values. Weyerhaeuser expressly disclaims any other warranties related to the software. Use of this software is not intended to circumvent the need for a design professional as determined by the authority having jurisdiction. The designer of record, builder or framer is responsible to assure that this calculation is compatible with the overall project. Accessories (Rim Board, Blocking Panels and Squash Blocks) are not designed by this software. Products manufactured at Weyerhaeuser facilities are third-party certified to sustainable forestry standards. Weyerhaeuser Engineered Lumber Products have been evaluated by ICC-ES under evaluation reports ESR-1153 and ESR-1387 and/or tested in accordance with applicable ASTM standards. For current code evaluation reports, Weyerhaeuser product literature and installation details refer to www.weyerhaeuser.com/woodproducts/document-library.

The product application, input design loads, dimensions and support information have been provided by ForteWEB Software Operator

ForteWEB Software Operator	Job Notes
Harrison Kliegl L120 Engineering (425) 636-3313 hkliegl@l120engineering.com	



8/23/2024 3:55:53 AM UTC
 ForteWEB v3.8, Engine: V8.4.1.24, Data: V8.1.6.3
 File Name: Granbois Residence

2nd Floor, 2B-10

1 piece(s) 5 1/2" x 10 1/2" 24F-V4 DF Glulam

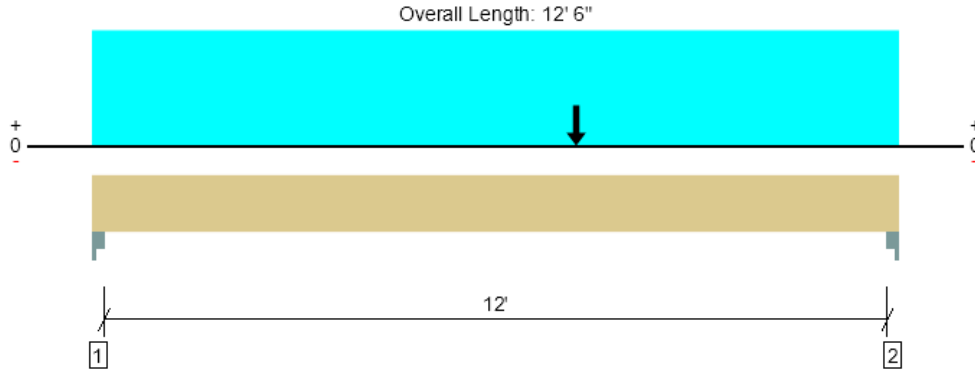

Drawing is Conceptual. All locations are measured from the outside face of left support (or left cantilever end). All dimensions are horizontal (typ.).

Design Results	Actual @ Location	Allowed	Result	LDF	Load: Combination (Pattern)
Member Reaction (lbs)	5388 @ 12' 4 1/2"	10725 (3.00")	Passed (50%)	--	1.0 D + 0.75 L + 0.75 S (All Spans)
Shear (lbs)	4464 @ 11' 4 1/2"	10203	Passed (44%)	1.00	1.0 D + 1.0 L (All Spans)
Pos Moment (Ft-lbs)	17220 @ 7' 4 15/16"	19934	Passed (86%)	1.00	1.0 D + 1.0 L (All Spans)
Live Load Defl. (in)	0.275 @ 6' 4"	0.408	Passed (L/535)	--	1.0 D + 0.75 L + 0.75 S (All Spans)
Total Load Defl. (in)	0.480 @ 6' 3 15/16"	0.613	Passed (L/306)	--	1.0 D + 0.75 L + 0.75 S (All Spans)

Member Length : 12' 6"
 System : Floor
 Member Type : Drop Beam
 Building Use : Residential
 Building Code : IBC 2021
 Design Methodology : ASD

- Deflection criteria: LL (L/360) and TL (L/240).
- A 1.4% decrease in the moment capacity has been added to account for lateral stability.
- Critical positive moment adjusted by a volume/size factor of 1.00 that was calculated using length L = 12' 3".
- The effects of positive or negative camber have not been accounted for when calculating deflection.
- The specified glulam is assumed to have its strong laminations at the bottom of the beam. Install with proper side up as indicated by the manufacturer.
- Applicable calculations are based on NDS.

Supports	Bearing Length			Loads to Supports (lbs)				Accessories
	Total	Available	Required	Dead	Floor Live	Snow	Factored	
1 - Column Cap - steel	3.00"	3.00"	1.50"	2191	2616	1219	5067	None
2 - Column Cap - steel	3.00"	3.00"	1.51"	2313	2880	1219	5388	None

Lateral Bracing	Bracing Intervals	Comments
Top Edge (Lu)	End Bearing Points	
Bottom Edge (Lu)	End Bearing Points	

Vertical Loads	Location (Side)	Tributary Width	Dead (0.90)	Floor Live (1.00)	Snow (1.15)	Comments
0 - Self Weight (PLF)	0 to 12' 6"	N/A	14.0	--	--	
1 - Uniform (PLF)	0 to 12' 6" (Top)	N/A	298.1	336.3	195.0	Linked from: 2J-5, Support 2
2 - Point (lb)	7' 6" (Top)	N/A	602	1293	-	Linked from: 2B-8, Support 2

• Side loads are assumed to not induce cross-grain tension.

Weyerhaeuser Notes

Weyerhaeuser warrants that the sizing of its products will be in accordance with Weyerhaeuser product design criteria and published design values. Weyerhaeuser expressly disclaims any other warranties related to the software. Use of this software is not intended to circumvent the need for a design professional as determined by the authority having jurisdiction. The designer of record, builder or framer is responsible to assure that this calculation is compatible with the overall project. Accessories (Rim Board, Blocking Panels and Squash Blocks) are not designed by this software. Products manufactured at Weyerhaeuser facilities are third-party certified to sustainable forestry standards. Weyerhaeuser Engineered Lumber Products have been evaluated by ICC-ES under evaluation reports ESR-1153 and ESR-1387 and/or tested in accordance with applicable ASTM standards. For current code evaluation reports, Weyerhaeuser product literature and installation details refer to www.weyerhaeuser.com/woodproducts/document-library.

The product application, input design loads, dimensions and support information have been provided by ForteWEB Software Operator

ForteWEB Software Operator	Job Notes
Harrison Kliegl L120 Engineering (425) 636-3313 hkliegl@l120engineering.com	



2nd Floor, 2B-11

1 piece(s) 5 1/2" x 10 1/2" 24F-V4 DF Glulam

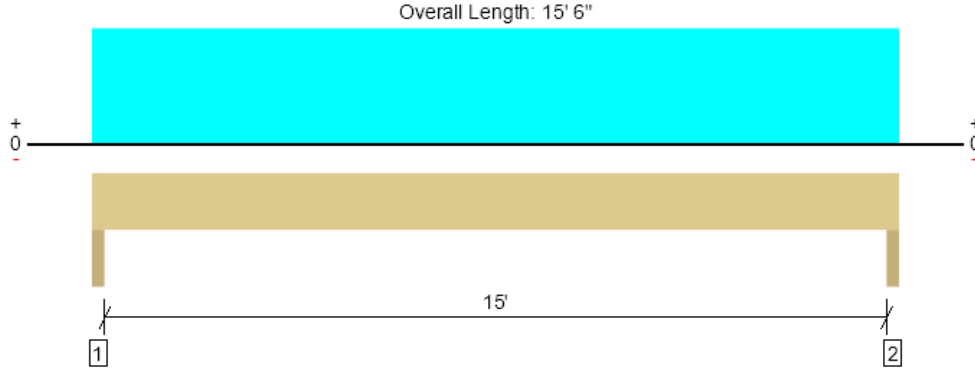

Drawing is Conceptual. All locations are measured from the outside face of left support (or left cantilever end). All dimensions are horizontal (typ.).

Design Results	Actual @ Location	Allowed	Result	LDF	Load: Combination (Pattern)
Member Reaction (lbs)	1768 @ 1 1/2"	10725 (3.00")	Passed (16%)	--	1.0 D + 0.75 L + 0.75 S (All Spans)
Shear (lbs)	1346 @ 1' 1 1/2"	10203	Passed (13%)	1.00	1.0 D + 1.0 L (All Spans)
Pos Moment (Ft-lbs)	5905 @ 7' 9"	19845	Passed (30%)	1.00	1.0 D + 1.0 L (All Spans)
Live Load Defl. (in)	0.096 @ 7' 9"	0.508	Passed (L/999+)	--	1.0 D + 0.75 L + 0.75 S (All Spans)
Total Load Defl. (in)	0.291 @ 7' 9"	0.762	Passed (L/630)	--	1.0 D + 0.75 L + 0.75 S (All Spans)

Member Length : 15' 6"
 System : Floor
 Member Type : Drop Beam
 Building Use : Residential
 Building Code : IBC 2021
 Design Methodology : ASD

- Deflection criteria: LL (L/360) and TL (L/240).
- A 1.8% decrease in the moment capacity has been added to account for lateral stability.
- Critical positive moment adjusted by a volume/size factor of 1.00 that was calculated using length L = 15' 3".
- The effects of positive or negative camber have not been accounted for when calculating deflection.
- The specified glulam is assumed to have its strong laminations at the bottom of the beam. Install with proper side up as indicated by the manufacturer.
- Applicable calculations are based on NDS.

Supports	Bearing Length			Loads to Supports (lbs)				Accessories
	Total	Available	Required	Dead	Floor Live	Snow	Factored	
1 - Trimmer - HF	3.00"	3.00"	1.50"	1187	388	388	1768	None
2 - Trimmer - HF	3.00"	3.00"	1.50"	1187	388	388	1768	None

Lateral Bracing	Bracing Intervals	Comments
Top Edge (Lu)	End Bearing Points	
Bottom Edge (Lu)	End Bearing Points	

Vertical Loads	Location (Side)	Tributary Width	Dead (0.90)	Floor Live (1.00)	Snow (1.15)	Comments
0 - Self Weight (PLF)	0 to 15' 6"	N/A	14.0	--	--	
1 - Uniform (PSF)	0 to 15' 6" (Top)	1' 3"	12.0	40.0	-	Floor Load
2 - Uniform (PLF)	0 to 15' 6" (Top)	N/A	100.0	-	-	Wall Load Above
3 - Uniform (PSF)	0 to 15' 6" (Top)	2'	12.0	-	25.0	Roof Load

• Side loads are assumed to not induce cross-grain tension.

Weyerhaeuser Notes

Weyerhaeuser warrants that the sizing of its products will be in accordance with Weyerhaeuser product design criteria and published design values. Weyerhaeuser expressly disclaims any other warranties related to the software. Use of this software is not intended to circumvent the need for a design professional as determined by the authority having jurisdiction. The designer of record, builder or framer is responsible to assure that this calculation is compatible with the overall project. Accessories (Rim Board, Blocking Panels and Squash Blocks) are not designed by this software. Products manufactured at Weyerhaeuser facilities are third-party certified to sustainable forestry standards. Weyerhaeuser Engineered Lumber Products have been evaluated by ICC-ES under evaluation reports ESR-1153 and ESR-1387 and/or tested in accordance with applicable ASTM standards. For current code evaluation reports, Weyerhaeuser product literature and installation details refer to www.weyerhaeuser.com/woodproducts/document-library.

The product application, input design loads, dimensions and support information have been provided by ForteWEB Software Operator

ForteWEB Software Operator	Job Notes
Harrison Kliegl L120 Engineering (425) 636-3313 hkliegl@l120engineering.com	



8/23/2024 3:55:53 AM UTC
 ForteWEB v3.8, Engine: V8.4.1.24, Data: V8.1.6.3
 File Name: Granbois Residence

2nd Floor, 2B-12

1 piece(s) 1 3/4" x 11 7/8" 2.0E Microllam® LVL

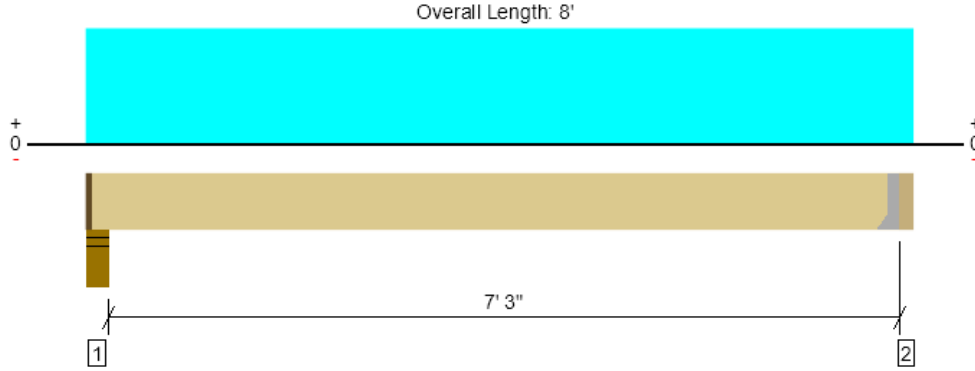

Drawing is Conceptual. All locations are measured from the outside face of left support (or left cantilever end). All dimensions are horizontal (typ.).

Design Results	Actual @ Location	Allowed	Result	LDF	Load: Combination (Pattern)
Member Reaction (lbs)	1365 @ 7' 8 1/2"	1969 (1.50")	Passed (69%)	--	1.0 D + 1.0 L (All Spans)
Shear (lbs)	998 @ 6' 8 5/8"	3948	Passed (25%)	1.00	1.0 D + 1.0 L (All Spans)
Moment (Ft-lbs)	2516 @ 4' 1/4"	8924	Passed (28%)	1.00	1.0 D + 1.0 L (All Spans)
Live Load Defl. (in)	0.049 @ 4' 1/4"	0.184	Passed (L/999+)	--	1.0 D + 1.0 L (All Spans)
Total Load Defl. (in)	0.064 @ 4' 1/4"	0.369	Passed (L/999+)	--	1.0 D + 1.0 L (All Spans)

Member Length : 7' 7"
 System : Floor
 Member Type : Flush Beam
 Building Use : Residential
 Building Code : IBC 2021
 Design Methodology : ASD

- Deflection criteria: LL (L/480) and TL (L/240).
- Allowed moment does not reflect the adjustment for the beam stability factor.

Supports	Bearing Length			Loads to Supports (lbs)			Accessories
	Total	Available	Required	Dead	Floor Live	Factored	
1 - Stud wall - HF	5.50"	4.00"	2.03"	361	1126	1487	1 1/2" Rim Board
2 - Hanger on 11 7/8" LVL beam	3.50"	Hanger ¹	1.50"	357	1114	1471	See note ¹

- Rim Board is assumed to carry all loads applied directly above it, bypassing the member being designed.
- At hanger supports, the Total Bearing dimension is equal to the width of the material that is supporting the hanger
- ¹ See Connector grid below for additional information and/or requirements.

Lateral Bracing	Bracing Intervals	Comments
Top Edge (Lu)	7' 7" o/c	
Bottom Edge (Lu)	7' 7" o/c	

•Maximum allowable bracing intervals based on applied load.

Connector: Simpson Strong-Tie

Support	Model	Seat Length	Top Fasteners	Face Fasteners	Member Fasteners	Accessories
2 - Face Mount Hanger	HUS1.81/10	3.00"	N/A	30-10dx1.5	10-10d	

- Refer to manufacturer notes and instructions for proper installation and use of all connectors.

Vertical Loads	Location (Side)	Tributary Width	Dead (0.90)	Floor Live (1.00)	Comments
0 - Self Weight (PLF)	1 1/2" to 7' 8 1/2"	N/A	6.1	--	
1 - Uniform (PSF)	0 to 8' (Front)	7'	12.0	40.0	Floor Load

- Side loads are assumed to not induce cross-grain tension.

Weyerhaeuser Notes

Weyerhaeuser warrants that the sizing of its products will be in accordance with Weyerhaeuser product design criteria and published design values. Weyerhaeuser expressly disclaims any other warranties related to the software. Use of this software is not intended to circumvent the need for a design professional as determined by the authority having jurisdiction. The designer of record, builder or framer is responsible to assure that this calculation is compatible with the overall project. Accessories (Rim Board, Blocking Panels and Squash Blocks) are not designed by this software. Products manufactured at Weyerhaeuser facilities are third-party certified to sustainable forestry standards. Weyerhaeuser Engineered Lumber Products have been evaluated by ICC-ES under evaluation reports ESR-1153 and ESR-1387 and/or tested in accordance with applicable ASTM standards. For current code evaluation reports, Weyerhaeuser product literature and installation details refer to www.weyerhaeuser.com/woodproducts/document-library.

The product application, input design loads, dimensions and support information have been provided by ForteWEB Software Operator

ForteWEB Software Operator	Job Notes
Harrison Kliegl L120 Engineering (425) 636-3313 hkliegl@l120engineering.com	



8/23/2024 3:55:53 AM UTC
 ForteWEB v3.8, Engine: V8.4.1.24, Data: V8.1.6.3
 File Name: Granbois Residence

2nd Floor, 2B-13

2 piece(s) 1 3/4" x 11 7/8" 2.0E Microllam® LVL

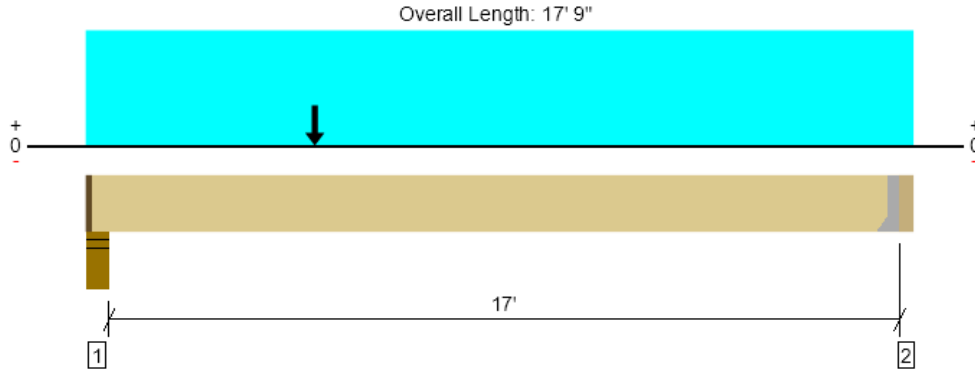

Drawing is Conceptual. All locations are measured from the outside face of left support (or left cantilever end). All dimensions are horizontal (typ.).

Design Results	Actual @ Location	Allowed	Result	LDF	Load: Combination (Pattern)
Member Reaction (lbs)	1633 @ 4"	5670 (4.00")	Passed (29%)	--	1.0 D + 1.0 L (All Spans)
Shear (lbs)	1548 @ 1' 5 3/8"	7897	Passed (20%)	1.00	1.0 D + 1.0 L (All Spans)
Moment (Ft-lbs)	6858 @ 5'	17848	Passed (38%)	1.00	1.0 D + 1.0 L (All Spans)
Live Load Defl. (in)	0.244 @ 8' 3 3/8"	0.428	Passed (L/841)	--	1.0 D + 1.0 L (All Spans)
Total Load Defl. (in)	0.346 @ 8' 3 7/8"	0.856	Passed (L/594)	--	1.0 D + 1.0 L (All Spans)

Member Length : 17' 4"
 System : Floor
 Member Type : Flush Beam
 Building Use : Residential
 Building Code : IBC 2021
 Design Methodology : ASD

- Deflection criteria: LL (L/480) and TL (L/240).
- Allowed moment does not reflect the adjustment for the beam stability factor.

Supports	Bearing Length			Loads to Supports (lbs)			Accessories
	Total	Available	Required	Dead	Floor Live	Factored	
1 - Stud wall - HF	5.50"	4.00"	1.50"	473	1166	1639	1 1/2" Rim Board
2 - Hanger on 11 7/8" LVL beam	3.50"	Hanger ¹	1.50"	307	658	965	See note ¹

- Rim Board is assumed to carry all loads applied directly above it, bypassing the member being designed.
- At hanger supports, the Total Bearing dimension is equal to the width of the material that is supporting the hanger
- ¹ See Connector grid below for additional information and/or requirements.

Lateral Bracing	Bracing Intervals	Comments
Top Edge (Lu)	17' 4" o/c	
Bottom Edge (Lu)	17' 4" o/c	

•Maximum allowable bracing intervals based on applied load.

Connector: Simpson Strong-Tie

Support	Model	Seat Length	Top Fasteners	Face Fasteners	Member Fasteners	Accessories
2 - Face Mount Hanger	LUS410	2.00"	N/A	8-10dx1.5	6-10d	

- Refer to manufacturer notes and instructions for proper installation and use of all connectors.

Vertical Loads	Location (Side)	Tributary Width	Dead (0.90)	Floor Live (1.00)	Comments
0 - Self Weight (PLF)	1 1/2" to 17' 5 1/2"	N/A	12.1	--	
1 - Uniform (PSF)	0 to 17' 9" (Front)	1'	12.0	40.0	Floor Load
2 - Point (lb)	5' (Front)	N/A	357	1114	Linked from: 2B-12, Support 2

• Side loads are assumed to not induce cross-grain tension.

Weyerhaeuser Notes

Weyerhaeuser warrants that the sizing of its products will be in accordance with Weyerhaeuser product design criteria and published design values. Weyerhaeuser expressly disclaims any other warranties related to the software. Use of this software is not intended to circumvent the need for a design professional as determined by the authority having jurisdiction. The designer of record, builder or framer is responsible to assure that this calculation is compatible with the overall project. Accessories (Rim Board, Blocking Panels and Squash Blocks) are not designed by this software. Products manufactured at Weyerhaeuser facilities are third-party certified to sustainable forestry standards. Weyerhaeuser Engineered Lumber Products have been evaluated by ICC-ES under evaluation reports ESR-1153 and ESR-1387 and/or tested in accordance with applicable ASTM standards. For current code evaluation reports, Weyerhaeuser product literature and installation details refer to www.weyerhaeuser.com/woodproducts/document-library.

The product application, input design loads, dimensions and support information have been provided by ForteWEB Software Operator

ForteWEB Software Operator	Job Notes
Harrison Kliegl L120 Engineering (425) 636-3313 hkliegl@l120engineering.com	



8/23/2024 3:55:53 AM UTC
 ForteWEB v3.8, Engine: V8.4.1.24, Data: V8.1.6.3
 File Name: Granbois Residence

2nd Floor, 2B-14

2 piece(s) 1 3/4" x 11 7/8" 2.0E Microllam® LVL

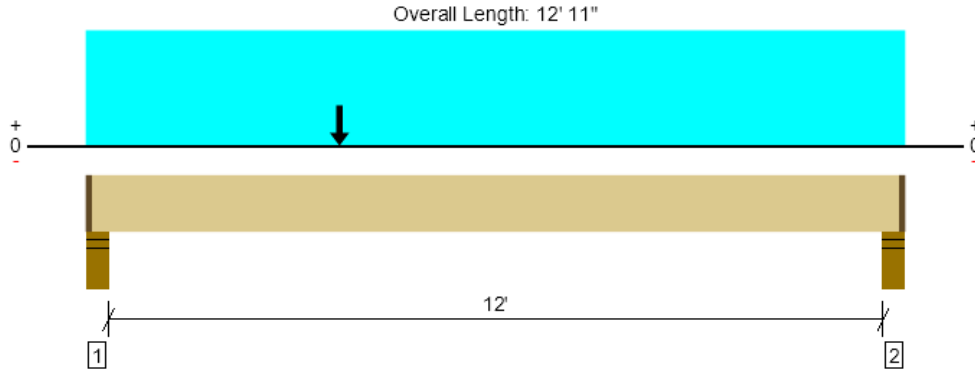

Drawing is Conceptual. All locations are measured from the outside face of left support (or left cantilever end). All dimensions are horizontal (typ.).

Design Results	Actual @ Location	Allowed	Result	LDF	Load: Combination (Pattern)
Member Reaction (lbs)	1741 @ 4"	5670 (4.00")	Passed (31%)	--	1.0 D + 1.0 L (All Spans)
Shear (lbs)	1519 @ 1' 5 3/8"	7897	Passed (19%)	1.00	1.0 D + 1.0 L (All Spans)
Moment (Ft-lbs)	5171 @ 4' 8 7/8"	17848	Passed (29%)	1.00	1.0 D + 1.0 L (All Spans)
Live Load Defl. (in)	0.107 @ 6' 3"	0.306	Passed (L/999+)	--	1.0 D + 1.0 L (All Spans)
Total Load Defl. (in)	0.153 @ 6' 2 15/16"	0.613	Passed (L/961)	--	1.0 D + 1.0 L (All Spans)

Member Length : 12' 8"
 System : Floor
 Member Type : Flush Beam
 Building Use : Residential
 Building Code : IBC 2021
 Design Methodology : ASD

- Deflection criteria: LL (L/480) and TL (L/240).
- Allowed moment does not reflect the adjustment for the beam stability factor.

Supports	Bearing Length			Loads to Supports (lbs)			Accessories
	Total	Available	Required	Dead	Floor Live	Factored	
1 - Stud wall - HF	5.50"	4.00"	1.50"	524	1236	1760	1 1/2" Rim Board
2 - Stud wall - HF	5.50"	4.00"	1.50"	401	972	1373	1 1/2" Rim Board

• Rim Board is assumed to carry all loads applied directly above it, bypassing the member being designed.

Lateral Bracing	Bracing Intervals	Comments
Top Edge (Lu)	12' 8" o/c	
Bottom Edge (Lu)	12' 8" o/c	

•Maximum allowable bracing intervals based on applied load.

Vertical Loads	Location (Side)	Tributary Width	Dead (0.90)	Floor Live (1.00)	Comments
0 - Self Weight (PLF)	1 1/2" to 12' 9 1/2"	N/A	12.1	--	
1 - Uniform (PSF)	0 to 12' 11" (Front)	3'	12.0	40.0	Floor Load
2 - Point (lb)	4' (Front)	N/A	307	658	Linked from: 2B-13, Support 2

• Side loads are assumed to not induce cross-grain tension.

Weyerhaeuser Notes
 Weyerhaeuser warrants that the sizing of its products will be in accordance with Weyerhaeuser product design criteria and published design values. Weyerhaeuser expressly disclaims any other warranties related to the software. Use of this software is not intended to circumvent the need for a design professional as determined by the authority having jurisdiction. The designer of record, builder or framer is responsible to assure that this calculation is compatible with the overall project. Accessories (Rim Board, Blocking Panels and Squash Blocks) are not designed by this software. Products manufactured at Weyerhaeuser facilities are third-party certified to sustainable forestry standards. Weyerhaeuser Engineered Lumber Products have been evaluated by ICC-ES under evaluation reports ESR-1153 and ESR-1387 and/or tested in accordance with applicable ASTM standards. For current code evaluation reports, Weyerhaeuser product literature and installation details refer to www.weyerhaeuser.com/woodproducts/document-library.
 The product application, input design loads, dimensions and support information have been provided by ForteWEB Software Operator

ForteWEB Software Operator	Job Notes
Harrison Kliegl L120 Engineering (425) 636-3313 hkliegl@l120engineering.com	



8/23/2024 3:55:53 AM UTC
 ForteWEB v3.8, Engine: V8.4.1.24, Data: V8.1.6.3
 File Name: Granbois Residence

2nd Floor, 2B-15

1 piece(s) 1 3/4" x 11 7/8" 2.0E Microllam® LVL

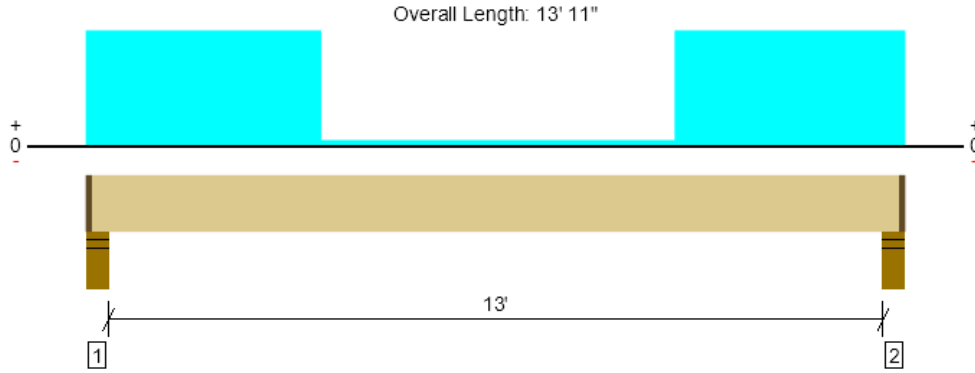

Drawing is Conceptual. All locations are measured from the outside face of left support (or left cantilever end). All dimensions are horizontal (typ.).

Design Results	Actual @ Location	Allowed	Result	LDF	Load: Combination (Pattern) [Group]
Member Reaction (lbs)	1290 @ 13' 7"	2835 (4.00")	Passed (46%)	--	1.0 D + 1.0 L (All Spans) [1]
Shear (lbs)	1042 @ 12' 5 5/8"	3948	Passed (26%)	1.00	1.0 D + 1.0 L (All Spans) [1]
Moment (Ft-lbs)	4154 @ 6' 11 1/2"	8924	Passed (47%)	1.00	1.0 D + 1.0 L (All Spans) [1]
Live Load Defl. (in)	0.243 @ 6' 11 1/2"	0.331	Passed (L/655)	--	1.0 D + 1.0 L (All Spans) [1]
Total Load Defl. (in)	0.292 @ 6' 11 1/2"	0.663	Passed (L/545)	--	1.0 D + 1.0 L (All Spans) [1]

Member Length : 13' 8"
 System : Floor
 Member Type : Flush Beam
 Building Use : Residential
 Building Code : IBC 2021
 Design Methodology : ASD

- Deflection criteria: LL (L/480) and TL (L/240).
- Allowed moment does not reflect the adjustment for the beam stability factor.

Supports	Bearing Length			Loads to Supports (lbs)				Accessories
	Total	Available	Required	Dead	Floor Live	Snow	Factored	
1 - Stud wall - HF	5.50"	4.00"	1.82"	260	1053	-20	1313	1 1/2" Rim Board
2 - Stud wall - HF	5.50"	4.00"	1.82"	259	1054	-20	1313	1 1/2" Rim Board

• Rim Board is assumed to carry all loads applied directly above it, bypassing the member being designed.

Lateral Bracing	Bracing Intervals	Comments
Top Edge (Lu)	10' 11" o/c	
Bottom Edge (Lu)	13' 8" o/c	

•Maximum allowable bracing intervals based on applied load.

Vertical Loads	Location (Side)	Tributary Width	Dead (0.90)	Floor Live (1.00)	Snow (1.15)	Comments
0 - Self Weight (PLF)	1 1/2" to 13' 9 1/2"	N/A	6.1	--	--	
1 - Uniform (PSF)	0 to 4' (Front)	3' 6"	12.0	40.0	-	Floor Load
2 - Uniform (PSF)	10' to 13' 11" (Front)	3' 6"	12.0	40.0	-	Floor Load
3 - Uniform (PLF)	4' to 10' (Front)	N/A	17.3	166.5/-1.5	-6.8	Linked from: 2J-6, Support 1

• Side loads are assumed to not induce cross-grain tension.

Weyerhaeuser Notes

Weyerhaeuser warrants that the sizing of its products will be in accordance with Weyerhaeuser product design criteria and published design values. Weyerhaeuser expressly disclaims any other warranties related to the software. Use of this software is not intended to circumvent the need for a design professional as determined by the authority having jurisdiction. The designer of record, builder or framer is responsible to assure that this calculation is compatible with the overall project. Accessories (Rim Board, Blocking Panels and Squash Blocks) are not designed by this software. Products manufactured at Weyerhaeuser facilities are third-party certified to sustainable forestry standards. Weyerhaeuser Engineered Lumber Products have been evaluated by ICC-ES under evaluation reports ESR-1153 and ESR-1387 and/or tested in accordance with applicable ASTM standards. For current code evaluation reports, Weyerhaeuser product literature and installation details refer to www.weyerhaeuser.com/woodproducts/document-library.

The product application, input design loads, dimensions and support information have been provided by ForteWEB Software Operator

ForteWEB Software Operator	Job Notes
Harrison Kliegl L120 Engineering (425) 636-3313 hkriegl@l120engineering.com	



8/23/2024 3:55:53 AM UTC
 ForteWEB v3.8, Engine: V8.4.1.24, Data: V8.1.6.3
 File Name: Granbois Residence

2nd Floor, 2B-16

1 piece(s) 1 3/4" x 11 7/8" 2.0E Microllam® LVL

Overall Length: 6' 8 1/2"

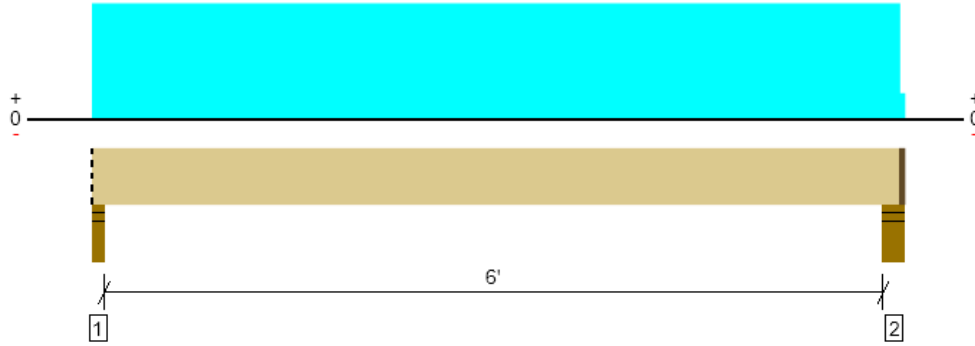

Drawing is Conceptual. All locations are measured from the outside face of left support (or left cantilever end). All dimensions are horizontal (typ.).

Design Results	Actual @ Location	Allowed	Result	LDF	Load: Combination (Pattern)
Member Reaction (lbs)	1934 @ 1 1/2"	2126 (3.00")	Passed (91%)	--	1.0 D + 1.0 L (All Spans)
Shear (lbs)	1197 @ 1' 2 7/8"	3948	Passed (30%)	1.00	1.0 D + 1.0 L (All Spans)
Moment (Ft-lbs)	2906 @ 3' 3"	8924	Passed (33%)	1.00	1.0 D + 1.0 L (All Spans)
Live Load Defl. (in)	0.036 @ 3' 3"	0.156	Passed (L/999+)	--	1.0 D + 1.0 L (All Spans)
Total Load Defl. (in)	0.058 @ 3' 3"	0.313	Passed (L/999+)	--	1.0 D + 1.0 L (All Spans)

Member Length : 6' 7"
 System : Floor
 Member Type : Flush Beam
 Building Use : Residential
 Building Code : IBC 2021
 Design Methodology : ASD

- Deflection criteria: LL (L/480) and TL (L/240).
- Allowed moment does not reflect the adjustment for the beam stability factor.

Supports	Bearing Length			Loads to Supports (lbs)				Accessories
	Total	Available	Required	Dead	Floor Live	Snow	Factored	
1 - Stud wall - HF	3.00"	3.00"	2.73"	732	1203	380	1934	Blocking
2 - Stud wall - HF	5.50"	4.00"	2.80"	770	1269	399	2040	1 1/2" Rim Board

- Rim Board is assumed to carry all loads applied directly above it, bypassing the member being designed.
- Blocking Panels are assumed to carry no loads applied directly above them and the full load is applied to the member being designed.

Lateral Bracing	Bracing Intervals	Comments
Top Edge (Lu)	6' 7" o/c	
Bottom Edge (Lu)	6' 7" o/c	

- Maximum allowable bracing intervals based on applied load.

Vertical Loads	Location (Side)	Tributary Width	Dead (0.90)	Floor Live (1.00)	Snow (1.15)	Comments
0 - Self Weight (PLF)	0 to 6' 7"	N/A	6.1	--	--	
1 - Uniform (PSF)	0 to 6' 8 1/2" (Back)	3'	12.0	40.0	-	Floor Load
2 - Uniform (PLF)	0 to 6' 8" (Front)	N/A	183.1	250.0	116.9	Linked from: 2J-2, Support 1

- Side loads are assumed to not induce cross-grain tension.

Weyerhaeuser Notes
 Weyerhaeuser warrants that the sizing of its products will be in accordance with Weyerhaeuser product design criteria and published design values. Weyerhaeuser expressly disclaims any other warranties related to the software. Use of this software is not intended to circumvent the need for a design professional as determined by the authority having jurisdiction. The designer of record, builder or framer is responsible to assure that this calculation is compatible with the overall project. Accessories (Rim Board, Blocking Panels and Squash Blocks) are not designed by this software. Products manufactured at Weyerhaeuser facilities are third-party certified to sustainable forestry standards. Weyerhaeuser Engineered Lumber Products have been evaluated by ICC-ES under evaluation reports ESR-1153 and ESR-1387 and/or tested in accordance with applicable ASTM standards. For current code evaluation reports, Weyerhaeuser product literature and installation details refer to www.weyerhaeuser.com/woodproducts/document-library.
 The product application, input design loads, dimensions and support information have been provided by ForteWEB Software Operator

ForteWEB Software Operator	Job Notes
Harrison Kliegl L120 Engineering (425) 636-3313 hkliegl@l120engineering.com	



8/23/2024 3:55:53 AM UTC
 ForteWEB v3.8, Engine: V8.4.1.24, Data: V8.1.6.3
 File Name: Granbois Residence

2nd Floor, 2B-17 (Beam over Living Room slider door)
1 piece(s) 3 1/2" x 15" 24F-V4 DF Glulam

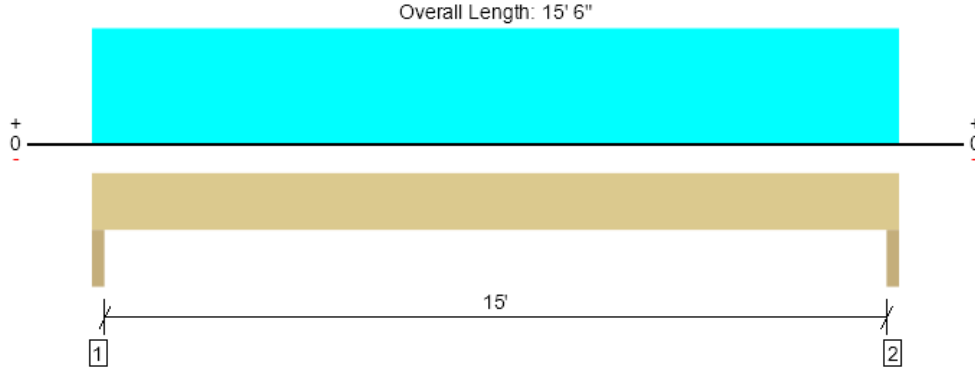

Drawing is Conceptual. All locations are measured from the outside face of left support (or left cantilever end). All dimensions are horizontal (typ.).

Design Results	Actual @ Location	Allowed	Result	LDF	Load: Combination (Pattern)
Member Reaction (lbs)	3181 @ 1 1/2"	6825 (3.00")	Passed (47%)	--	1.0 D + 0.75 L + 0.75 S (All Spans)
Shear (lbs)	2442 @ 1' 6"	9275	Passed (26%)	1.00	1.0 D + 1.0 L (All Spans)
Pos Moment (Ft-lbs)	11360 @ 7' 9"	21570	Passed (53%)	1.00	1.0 D + 1.0 L (All Spans)
Live Load Defl. (in)	0.230 @ 7' 9"	0.508	Passed (L/796)	--	1.0 D + 0.75 L + 0.75 S (All Spans)
Total Load Defl. (in)	0.282 @ 7' 9"	0.762	Passed (L/649)	--	1.0 D + 0.75 L + 0.75 S (All Spans)

Member Length : 15' 6"
 System : Floor
 Member Type : Drop Beam
 Building Use : Residential
 Building Code : IBC 2021
 Design Methodology : ASD

- Deflection criteria: LL (L/360) and TL (L/240).
- A 17.8% decrease in the moment capacity has been added to account for lateral stability.
- Critical positive moment adjusted by a volume/size factor of 1.00 that was calculated using length L = 15' 3".
- The effects of positive or negative camber have not been accounted for when calculating deflection.
- The specified glulam is assumed to have its strong laminations at the bottom of the beam. Install with proper side up as indicated by the manufacturer.
- Applicable calculations are based on NDS.

Supports	Bearing Length			Loads to Supports (lbs)				Accessories
	Total	Available	Required	Dead	Floor Live	Snow	Factored	
1 - Trimmer - HF	3.00"	3.00"	1.50"	587	2441	1017	3181	None
2 - Trimmer - HF	3.00"	3.00"	1.50"	587	2441	1017	3181	None

Lateral Bracing	Bracing Intervals	Comments
Top Edge (Lu)	End Bearing Points	
Bottom Edge (Lu)	End Bearing Points	

Vertical Loads	Location (Side)	Tributary Width	Dead (0.90)	Floor Live (1.00)	Snow (1.15)	Comments
0 - Self Weight (PLF)	0 to 15' 6"	N/A	12.8	--	--	
1 - Uniform (PLF)	0 to 15' 6" (Top)	N/A	63.0	315.0	131.3	Linked from: 2J-3 (Deck Joist), Support 2

• Side loads are assumed to not induce cross-grain tension.

Weyerhaeuser Notes

Weyerhaeuser warrants that the sizing of its products will be in accordance with Weyerhaeuser product design criteria and published design values. Weyerhaeuser expressly disclaims any other warranties related to the software. Use of this software is not intended to circumvent the need for a design professional as determined by the authority having jurisdiction. The designer of record, builder or framer is responsible to assure that this calculation is compatible with the overall project. Accessories (Rim Board, Blocking Panels and Squash Blocks) are not designed by this software. Products manufactured at Weyerhaeuser facilities are third-party certified to sustainable forestry standards. Weyerhaeuser Engineered Lumber Products have been evaluated by ICC-ES under evaluation reports ESR-1153 and ESR-1387 and/or tested in accordance with applicable ASTM standards. For current code evaluation reports, Weyerhaeuser product literature and installation details refer to www.weyerhaeuser.com/woodproducts/document-library.

The product application, input design loads, dimensions and support information have been provided by ForteWEB Software Operator

ForteWEB Software Operator	Job Notes
Harrison Kliegl L120 Engineering (425) 636-3313 hkliegl@l120engineering.com	



8/23/2024 3:55:53 AM UTC
 ForteWEB v3.8, Engine: V8.4.1.24, Data: V8.1.6.3
 File Name: Granbois Residence

1st Floor, 1H-1
1 piece(s) 6 x 10 DF No.2

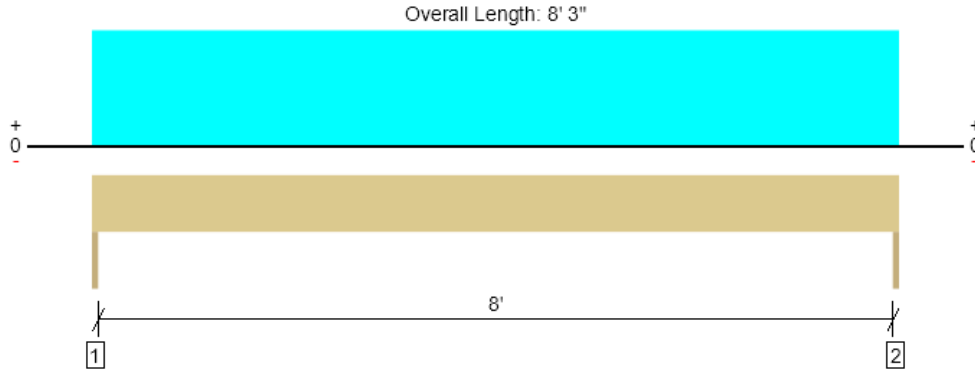

Drawing is Conceptual. All locations are measured from the outside face of left support (or left cantilever end). All dimensions are horizontal (typ.).

Design Results	Actual @ Location	Allowed	Result	LDF	Load: Combination (Pattern)
Member Reaction (lbs)	2010 @ 0	5156 (1.50")	Passed (39%)	--	1.0 D + 1.0 L (All Spans)
Shear (lbs)	1563 @ 11"	5922	Passed (26%)	1.00	1.0 D + 1.0 L (All Spans)
Moment (Ft-lbs)	4145 @ 4' 1 1/2"	6002	Passed (69%)	1.00	1.0 D + 1.0 L (All Spans)
Live Load Defl. (in)	0.052 @ 4' 1 1/2"	0.275	Passed (L/999+)	--	1.0 D + 1.0 L (All Spans)
Total Load Defl. (in)	0.099 @ 4' 1 1/2"	0.412	Passed (L/996)	--	1.0 D + 1.0 L (All Spans)

Member Length : 8' 3"
 System : Wall
 Member Type : Header
 Building Use : Residential
 Building Code : IBC 2021
 Design Methodology : ASD

- Deflection criteria: LL (L/360) and TL (L/240).
- A 0.5% decrease in the moment capacity has been added to account for lateral stability.
- Lumber grading provisions must be extended over the length of the member per NDS 4.2.5.5.
- Applicable calculations are based on NDS.

Supports	Bearing Length			Loads to Supports (lbs)				Accessories
	Total	Available	Required	Dead	Floor Live	Snow	Factored	
1 - Trimmer - HF	1.50"	1.50"	1.50"	952	1058	130	2010	None
2 - Trimmer - HF	1.50"	1.50"	1.50"	952	1058	130	2010	None

Lateral Bracing	Bracing Intervals	Comments
Top Edge (Lu)	End Bearing Points	
Bottom Edge (Lu)	End Bearing Points	

Vertical Loads	Location	Tributary Width	Dead (0.90)	Floor Live (1.00)	Snow (1.15)	Comments
0 - Self Weight (PLF)	0 to 8' 3"	N/A	13.2	--	--	
1 - Uniform (PLF)	0 to 8' 3"	N/A	217.5	256.5	31.5	Linked from: 2J-6, Support 2

Weyerhaeuser Notes

Weyerhaeuser warrants that the sizing of its products will be in accordance with Weyerhaeuser product design criteria and published design values. Weyerhaeuser expressly disclaims any other warranties related to the software. Use of this software is not intended to circumvent the need for a design professional as determined by the authority having jurisdiction. The designer of record, builder or framer is responsible to assure that this calculation is compatible with the overall project. Accessories (Rim Board, Blocking Panels and Squash Blocks) are not designed by this software. Products manufactured at Weyerhaeuser facilities are third-party certified to sustainable forestry standards. Weyerhaeuser Engineered Lumber Products have been evaluated by ICC-ES under evaluation reports ESR-1153 and ESR-1387 and/or tested in accordance with applicable ASTM standards. For current code evaluation reports, Weyerhaeuser product literature and installation details refer to www.weyerhaeuser.com/woodproducts/document-library.

The product application, input design loads, dimensions and support information have been provided by ForteWEB Software Operator

ForteWEB Software Operator	Job Notes
Harrison Kliegl L120 Engineering (425) 636-3313 hkliegl@l120engineering.com	



8/23/2024 3:55:53 AM UTC
 ForteWEB v3.8, Engine: V8.4.1.24, Data: V8.1.6.3
 File Name: Granbois Residence

1st Floor, 1H-2
1 piece(s) 4 x 10 DF No.2

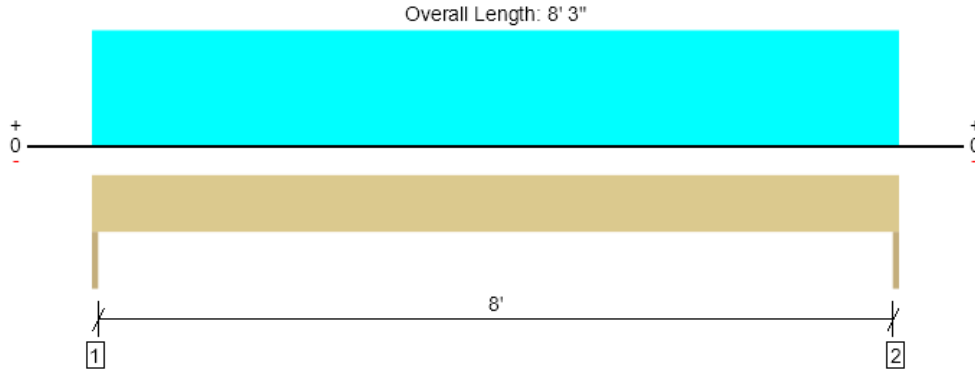

Drawing is Conceptual. All locations are measured from the outside face of left support (or left cantilever end). All dimensions are horizontal (typ.).

Design Results	Actual @ Location	Allowed	Result	LDF	Load: Combination (Pattern)
Member Reaction (lbs)	1535 @ 0	3281 (1.50")	Passed (47%)	--	1.0 D + 1.0 L (All Spans)
Shear (lbs)	1202 @ 10 3/4"	3885	Passed (31%)	1.00	1.0 D + 1.0 L (All Spans)
Moment (Ft-lbs)	3167 @ 4' 1 1/2"	4430	Passed (71%)	1.00	1.0 D + 1.0 L (All Spans)
Live Load Defl. (in)	0.079 @ 4' 1 1/2"	0.275	Passed (L/999+)	--	1.0 D + 1.0 L (All Spans)
Total Load Defl. (in)	0.105 @ 4' 1 1/2"	0.412	Passed (L/943)	--	1.0 D + 1.0 L (All Spans)

Member Length : 8' 3"
 System : Wall
 Member Type : Header
 Building Use : Residential
 Building Code : IBC 2021
 Design Methodology : ASD

- Deflection criteria: LL (L/360) and TL (L/240).
- A 1.4% decrease in the moment capacity has been added to account for lateral stability.
- Applicable calculations are based on NDS.

Supports	Bearing Length			Loads to Supports (lbs)			Accessories
	Total	Available	Required	Dead	Floor Live	Factored	
1 - Trimmer - HF	1.50"	1.50"	1.50"	380	1155	1535	None
2 - Trimmer - HF	1.50"	1.50"	1.50"	380	1155	1535	None

Lateral Bracing	Bracing Intervals	Comments
Top Edge (Lu)	End Bearing Points	
Bottom Edge (Lu)	End Bearing Points	

Vertical Loads	Location	Tributary Width	Dead (0.90)	Floor Live (1.00)	Comments
0 - Self Weight (PLF)	0 to 8' 3"	N/A	8.2	--	
1 - Uniform (PSF)	0 to 8' 3"	7'	12.0	40.0	Floor Load

Weyerhaeuser Notes

Weyerhaeuser warrants that the sizing of its products will be in accordance with Weyerhaeuser product design criteria and published design values. Weyerhaeuser expressly disclaims any other warranties related to the software. Use of this software is not intended to circumvent the need for a design professional as determined by the authority having jurisdiction. The designer of record, builder or framer is responsible to assure that this calculation is compatible with the overall project. Accessories (Rim Board, Blocking Panels and Squash Blocks) are not designed by this software. Products manufactured at Weyerhaeuser facilities are third-party certified to sustainable forestry standards. Weyerhaeuser Engineered Lumber Products have been evaluated by ICC-ES under evaluation reports ESR-1153 and ESR-1387 and/or tested in accordance with applicable ASTM standards. For current code evaluation reports, Weyerhaeuser product literature and installation details refer to www.weyerhaeuser.com/woodproducts/document-library.

The product application, input design loads, dimensions and support information have been provided by ForteWEB Software Operator

ForteWEB Software Operator	Job Notes
Harrison Kliegl L120 Engineering (425) 636-3313 hkliegl@l120engineering.com	



8/23/2024 3:55:53 AM UTC
 ForteWEB v3.8, Engine: V8.4.1.24, Data: V8.1.6.3
 File Name: Granbois Residence

1st Floor, 1H-3
1 piece(s) 4 x 6 DF No.2

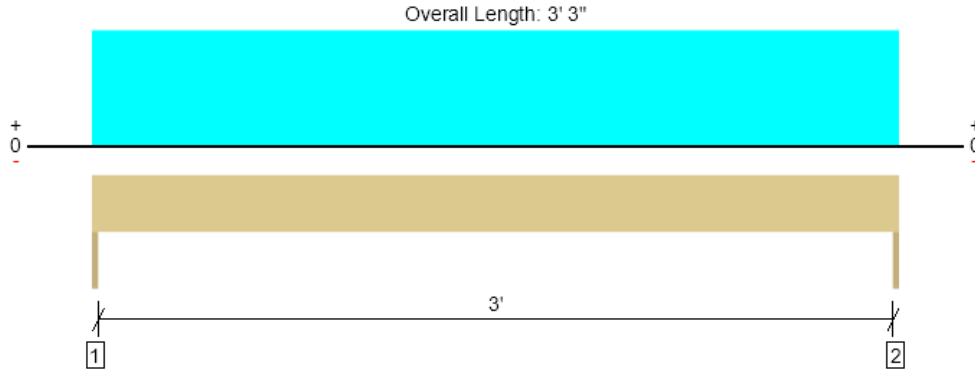

Drawing is Conceptual. All locations are measured from the outside face of left support (or left cantilever end). All dimensions are horizontal (typ.).

Design Results	Actual @ Location	Allowed	Result	LDF	Load: Combination (Pattern)
Member Reaction (lbs)	1147 @ 0	3281 (1.50")	Passed (35%)	--	1.0 D + 1.0 S (All Spans)
Shear (lbs)	736 @ 7"	2657	Passed (28%)	1.15	1.0 D + 1.0 S (All Spans)
Moment (Ft-lbs)	932 @ 1' 7 1/2"	1971	Passed (47%)	1.15	1.0 D + 1.0 S (All Spans)
Live Load Defl. (in)	0.014 @ 1' 7 1/2"	0.108	Passed (L/999+)	--	1.0 D + 1.0 S (All Spans)
Total Load Defl. (in)	0.023 @ 1' 7 1/2"	0.162	Passed (L/999+)	--	1.0 D + 1.0 S (All Spans)

Member Length : 3' 3"
 System : Wall
 Member Type : Header
 Building Use : Residential
 Building Code : IBC 2021
 Design Methodology : ASD

- Deflection criteria: LL (L/360) and TL (L/240).
- A 0.4% decrease in the moment capacity has been added to account for lateral stability.
- Applicable calculations are based on NDS.

Supports	Bearing Length			Loads to Supports (lbs)			Accessories
	Total	Available	Required	Dead	Snow	Factored	
1 - Trimmer - HF	1.50"	1.50"	1.50"	457	691	1147	None
2 - Trimmer - HF	1.50"	1.50"	1.50"	457	691	1147	None

Lateral Bracing	Bracing Intervals	Comments
Top Edge (Lu)	End Bearing Points	
Bottom Edge (Lu)	End Bearing Points	

Vertical Loads	Location	Tributary Width	Dead (0.90)	Snow (1.15)	Comments
0 - Self Weight (PLF)	0 to 3' 3"	N/A	4.9	--	
1 - Uniform (PSF)	0 to 3' 3"	17'	16.2	25.0	Roof Load

Weyerhaeuser Notes

Weyerhaeuser warrants that the sizing of its products will be in accordance with Weyerhaeuser product design criteria and published design values. Weyerhaeuser expressly disclaims any other warranties related to the software. Use of this software is not intended to circumvent the need for a design professional as determined by the authority having jurisdiction. The designer of record, builder or framer is responsible to assure that this calculation is compatible with the overall project. Accessories (Rim Board, Blocking Panels and Squash Blocks) are not designed by this software. Products manufactured at Weyerhaeuser facilities are third-party certified to sustainable forestry standards. Weyerhaeuser Engineered Lumber Products have been evaluated by ICC-ES under evaluation reports ESR-1153 and ESR-1387 and/or tested in accordance with applicable ASTM standards. For current code evaluation reports, Weyerhaeuser product literature and installation details refer to www.weyerhaeuser.com/woodproducts/document-library.

The product application, input design loads, dimensions and support information have been provided by ForteWEB Software Operator

ForteWEB Software Operator	Job Notes
Harrison Kliegl L120 Engineering (425) 636-3313 hkriegl@l120engineering.com	



8/23/2024 3:55:53 AM UTC
 ForteWEB v3.8, Engine: V8.4.1.24, Data: V8.1.6.3
 File Name: Granbois Residence

1st Floor, 1H-4

1 piece(s) 3 1/2" x 7 1/2" 24F-V4 DF Glulam

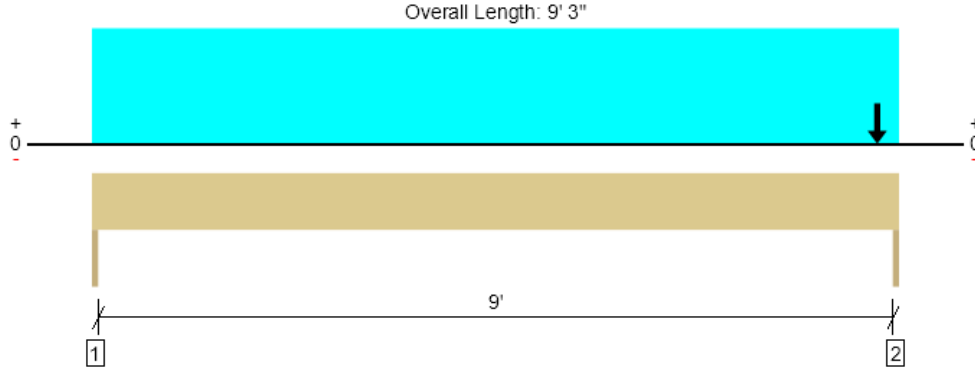

Drawing is Conceptual. All locations are measured from the outside face of left support (or left cantilever end). All dimensions are horizontal (typ.).

Design Results	Actual @ Location	Allowed	Result	LDF	Load: Combination (Pattern)
Member Reaction (lbs)	2342 @ 9' 3"	3413 (1.50")	Passed (69%)	--	1.0 D + 0.75 L + 0.75 S (All Spans)
Shear (lbs)	628 @ 8' 6"	4638	Passed (14%)	1.00	1.0 D + 1.0 L (All Spans)
Pos Moment (Ft-lbs)	909 @ 5' 7"	6432	Passed (14%)	1.00	1.0 D + 1.0 L (All Spans)
Live Load Defl. (in)	0.037 @ 4' 9 1/8"	0.308	Passed (L/999+)	--	1.0 D + 1.0 L (All Spans)
Total Load Defl. (in)	0.065 @ 4' 10 1/8"	0.463	Passed (L/999+)	--	1.0 D + 1.0 L (All Spans)

Member Length : 9' 3"
 System : Wall
 Member Type : Header
 Building Use : Residential
 Building Code : IBC 2021
 Design Methodology : ASD

- Deflection criteria: LL (L/360) and TL (L/240).
- A 2% decrease in the moment capacity has been added to account for lateral stability.
- Critical positive moment adjusted by a volume/size factor of 1.00 that was calculated using length L = 9' 3".
- The effects of positive or negative camber have not been accounted for when calculating deflection.
- The specified glulam is assumed to have its strong laminations at the bottom of the beam. Install with proper side up as indicated by the manufacturer.
- Applicable calculations are based on NDS.

Supports	Bearing Length			Loads to Supports (lbs)				Accessories
	Total	Available	Required	Dead	Floor Live	Snow	Factored	
1 - Trimmer - HF	1.50"	1.50"	1.50"	121	205	11	326	None
2 - Trimmer - HF	1.50"	1.50"	1.50"	1380	899	383	2342	None

Lateral Bracing	Bracing Intervals	Comments
Top Edge (Lu)	End Bearing Points	
Bottom Edge (Lu)	End Bearing Points	

Vertical Loads	Location	Tributary Width	Dead (0.90)	Floor Live (1.00)	Snow (1.15)	Comments
0 - Self Weight (PLF)	0 to 9' 3"	N/A	6.4	--	--	
1 - Uniform (PSF)	0 to 9' 3"	1'	12.0	40.0	-	Floor Load
2 - Point (lb)	9'	N/A	1331	734	394	Linked from: 2B-9, Support 1

Weyerhaeuser Notes

Weyerhaeuser warrants that the sizing of its products will be in accordance with Weyerhaeuser product design criteria and published design values. Weyerhaeuser expressly disclaims any other warranties related to the software. Use of this software is not intended to circumvent the need for a design professional as determined by the authority having jurisdiction. The designer of record, builder or framer is responsible to assure that this calculation is compatible with the overall project. Accessories (Rim Board, Blocking Panels and Squash Blocks) are not designed by this software. Products manufactured at Weyerhaeuser facilities are third-party certified to sustainable forestry standards. Weyerhaeuser Engineered Lumber Products have been evaluated by ICC-ES under evaluation reports ESR-1153 and ESR-1387 and/or tested in accordance with applicable ASTM standards. For current code evaluation reports, Weyerhaeuser product literature and installation details refer to www.weyerhaeuser.com/woodproducts/document-library.

The product application, input design loads, dimensions and support information have been provided by ForteWEB Software Operator

ForteWEB Software Operator	Job Notes
Harrison Kliegl L120 Engineering (425) 636-3313 hkliegl@l120engineering.com	



8/23/2024 3:55:53 AM UTC
 ForteWEB v3.8, Engine: V8.4.1.24, Data: V8.1.6.3
 File Name: Granbois Residence

1st Floor, 1J-1
1 piece(s) 11 7/8" TJI@ 210 @ 12" OC

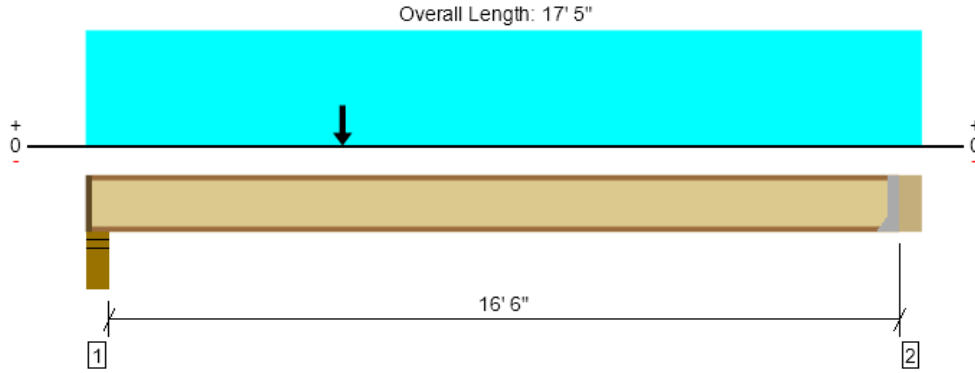

Drawing is Conceptual. All locations are measured from the outside face of left support (or left cantilever end). All dimensions are horizontal (typ.).

Design Results	Actual @ Location	Allowed	Result	LDF	Load: Combination (Pattern)
Member Reaction (lbs)	513 @ 16' 11 1/2"	1005 (1.75")	Passed (51%)	1.00	1.0 D + 1.0 L (All Spans)
Shear (lbs)	609 @ 5 1/2"	1655	Passed (37%)	1.00	1.0 D + 1.0 L (All Spans)
Moment (Ft-lbs)	2528 @ 7' 1 3/16"	3795	Passed (67%)	1.00	1.0 D + 1.0 L (All Spans)
Live Load Defl. (in)	0.239 @ 8' 6 11/16"	0.415	Passed (L/833)	--	1.0 D + 1.0 L (All Spans)
Total Load Defl. (in)	0.375 @ 8' 5 1/4"	0.829	Passed (L/530)	--	1.0 D + 1.0 L (All Spans)
TJ-Pro™ Rating	46	40	Passed	--	--

Member Length : 16' 10"
 System : Floor
 Member Type : Joist
 Building Use : Residential
 Building Code : IBC 2021
 Design Methodology : ASD

- Deflection criteria: LL (L/480) and TL (L/240).
- Allowed moment does not reflect the adjustment for the beam stability factor.
- A structural analysis of the deck has not been performed.
- Deflection analysis is based on composite action with a single layer of 23/32" Weyerhaeuser Edge™ Panel (24" Span Rating) that is glued and nailed down.
- Additional considerations for the TJ-Pro™ Rating include: None.

Supports	Bearing Length			Loads to Supports (lbs)			Accessories
	Total	Available	Required	Dead	Floor Live	Factored	
1 - Stud wall - DF	5.50"	4.00"	1.75"	231	402	633	1 1/2" Rim Board
2 - Hanger on 11 7/8" DF beam	5.50"	Hanger ¹	1.75" / - ²	162	375	537	See note ¹

- Rim Board is assumed to carry all loads applied directly above it, bypassing the member being designed.
- At hanger supports, the Total Bearing dimension is equal to the width of the material that is supporting the hanger
- ¹ See Connector grid below for additional information and/or requirements.
- ² Required Bearing Length / Required Bearing Length with Web Stiffeners

Lateral Bracing	Bracing Intervals	Comments
Top Edge (Lu)	4' 7" o/c	
Bottom Edge (Lu)	16' 10" o/c	

- TJI joists are only analyzed using Maximum Allowable bracing solutions.
- Maximum allowable bracing intervals based on applied load.

Connector: Simpson Strong-Tie

Support	Model	Seat Length	Top Fasteners	Face Fasteners	Member Fasteners	Accessories
2 - Face Mount Hanger	IUS2.06/11.88	2.00"	N/A	10-10dx1.5	2-Strong-Grip	

- Refer to manufacturer notes and instructions for proper installation and use of all connectors.

Vertical Loads	Location	Spacing	Dead (0.90)	Floor Live (1.00)	Comments
1 - Uniform (PSF)	0 to 17' 5"	12"	12.0	40.0	Floor Load
2 - Point (PLF)	5' 6"	12"	160.0	-	2 levels wall load
3 - Point (PLF)	5' 6"	12"	24.0	80.0	DL = 12psf * 2ft LL = 40 psf * 2ft

ForteWEB Software Operator	Job Notes
Harrison Kliegl L120 Engineering (425) 636-3313 hkliegl@l120engineering.com	



Weyerhaeuser Notes

Weyerhaeuser warrants that the sizing of its products will be in accordance with Weyerhaeuser product design criteria and published design values. Weyerhaeuser expressly disclaims any other warranties related to the software. Use of this software is not intended to circumvent the need for a design professional as determined by the authority having jurisdiction. The designer of record, builder or framer is responsible to assure that this calculation is compatible with the overall project. Accessories (Rim Board, Blocking Panels and Squash Blocks) are not designed by this software. Products manufactured at Weyerhaeuser facilities are third-party certified to sustainable forestry standards. Weyerhaeuser Engineered Lumber Products have been evaluated by ICC-ES under evaluation reports ESR-1153 and ESR-1387 and/or tested in accordance with applicable ASTM standards. For current code evaluation reports, Weyerhaeuser product literature and installation details refer to www.weyerhaeuser.com/woodproducts/document-library.

The product application, input design loads, dimensions and support information have been provided by ForteWEB Software Operator

ForteWEB Software Operator	Job Notes
Harrison Kliegl L120 Engineering (425) 636-3313 hkliegl@l120engineering.com	



1st Floor, 1J-2

1 piece(s) 11 7/8" TJI@ 210 @ 16" OC

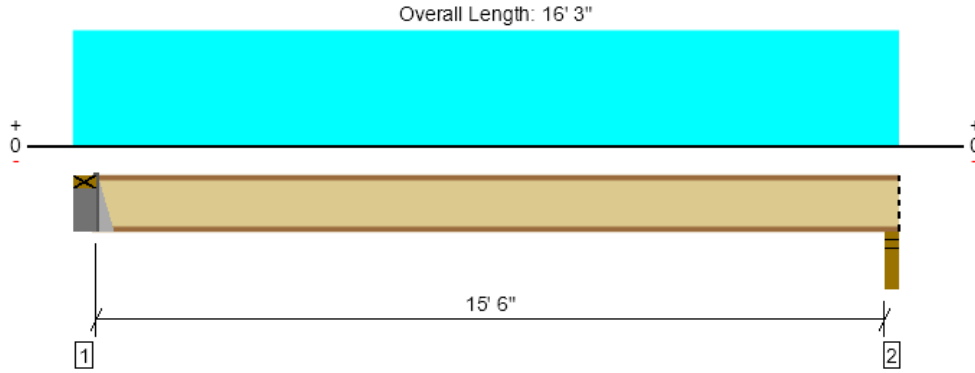

Drawing is Conceptual. All locations are measured from the outside face of left support (or left cantilever end). All dimensions are horizontal (typ.).

Design Results	Actual @ Location	Allowed	Result	LDF	Load: Combination (Pattern)
Member Reaction (lbs)	540 @ 5 1/2"	1005 (1.75")	Passed (54%)	1.00	1.0 D + 1.0 L (All Spans)
Shear (lbs)	540 @ 5 1/2"	1655	Passed (33%)	1.00	1.0 D + 1.0 L (All Spans)
Moment (Ft-lbs)	2105 @ 8' 3"	3795	Passed (55%)	1.00	1.0 D + 1.0 L (All Spans)
Live Load Defl. (in)	0.212 @ 8' 3"	0.390	Passed (L/883)	--	1.0 D + 1.0 L (All Spans)
Total Load Defl. (in)	0.275 @ 8' 3"	0.779	Passed (L/679)	--	1.0 D + 1.0 L (All Spans)
TJ-Pro™ Rating	47	40	Passed	--	--

Member Length : 15' 9 1/2"
 System : Floor
 Member Type : Joist
 Building Use : Residential
 Building Code : IBC 2021
 Design Methodology : ASD

- Deflection criteria: LL (L/480) and TL (L/240).
- Allowed moment does not reflect the adjustment for the beam stability factor.
- A structural analysis of the deck has not been performed.
- Deflection analysis is based on composite action with a single layer of 23/32" Weyerhaeuser Edge™ Panel (24" Span Rating) that is glued and nailed down.
- Additional considerations for the TJ-Pro™ Rating include: None.

Supports	Bearing Length			Loads to Supports (lbs)			Accessories
	Total	Available	Required	Dead	Floor Live	Factored	
1 - Hanger on Single 2X DF plate	5.50"	Hanger ¹	1.75" / - ²	132	440	572	See note ¹
2 - Stud wall - DF	3.50"	3.50"	1.75"	128	427	555	Blocking

- Blocking Panels are assumed to carry no loads applied directly above them and the full load is applied to the member being designed.
- At hanger supports, the Total Bearing dimension is equal to the width of the material that is supporting the hanger
- ¹ See Connector grid below for additional information and/or requirements.
- ² Required Bearing Length / Required Bearing Length with Web Stiffeners

Lateral Bracing	Bracing Intervals	Comments
Top Edge (Lu)	5' 1" o/c	
Bottom Edge (Lu)	15' 10" o/c	

- TJI joists are only analyzed using Maximum Allowable bracing solutions.
- Maximum allowable bracing intervals based on applied load.

Connector: Simpson Strong-Tie

Support	Model	Seat Length	Top Fasteners	Face Fasteners	Member Fasteners	Accessories
1 - Top Mount Hanger	ITS2.06/11.88	2.00"	4-10dx1.5	2-10dx1.5	2-Strong-Grip	

- Refer to manufacturer notes and instructions for proper installation and use of all connectors.

Vertical Load	Location	Spacing	Dead (0.90)	Floor Live (1.00)	Comments
1 - Uniform (PSF)	0 to 16' 3"	16"	12.0	40.0	Floor Load

Weyerhaeuser Notes

Weyerhaeuser warrants that the sizing of its products will be in accordance with Weyerhaeuser product design criteria and published design values. Weyerhaeuser expressly disclaims any other warranties related to the software. Use of this software is not intended to circumvent the need for a design professional as determined by the authority having jurisdiction. The designer of record, builder or framer is responsible to assure that this calculation is compatible with the overall project. Accessories (Rim Board, Blocking Panels and Squash Blocks) are not designed by this software. Products manufactured at Weyerhaeuser facilities are third-party certified to sustainable forestry standards. Weyerhaeuser Engineered Lumber Products have been evaluated by ICC-ES under evaluation reports ESR-1153 and ESR-1387 and/or tested in accordance with applicable ASTM standards. For current code evaluation reports, Weyerhaeuser product literature and installation details refer to www.weyerhaeuser.com/woodproducts/document-library.

The product application, input design loads, dimensions and support information have been provided by ForteWEB Software Operator

ForteWEB Software Operator	Job Notes
Harrison Kliegl L120 Engineering (425) 636-3313 hkliegl@l120engineering.com	



8/23/2024 3:55:53 AM UTC
 ForteWEB v3.8, Engine: V8.4.1.24, Data: V8.1.6.3
 File Name: Granbois Residence

1st Floor, 1B-1

1 piece(s) 3 1/2" x 11 7/8" 2.2E Parallam® PSL

An excessive uplift of -2152 lbs at support located at 14' 8 1/2" failed this product.

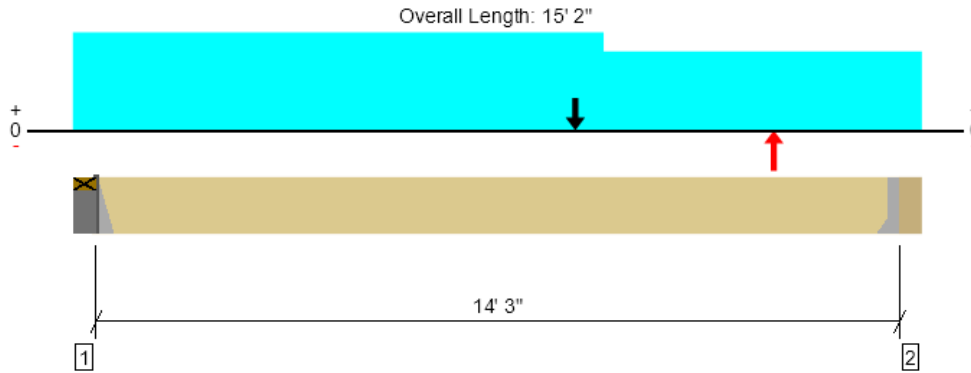

Drawing is Conceptual. All locations are measured from the outside face of left support (or left cantilever end). All dimensions are horizontal (typ.).

Design Results	Actual @ Location	Allowed	Result	LDF	Load: Combination (Pattern)
Member Reaction (lbs)	4886 @ 14' 8 1/2"	4886 (2.23")	Passed (100%)	--	1.0 D - 0.525 E + 0.75 L + 0.75 S (All Spans)
Shear (lbs)	6056 @ 12' 6"	12857	Passed (47%)	1.60	1.0 D + 0.7 E (All Spans)
Moment (Ft-lbs)	12758 @ 7' 4 13/16"	19902	Passed (64%)	1.00	1.0 D + 1.0 L (All Spans)
Live Load Defl. (in)	0.297 @ 7' 7 1/16"	0.356	Passed (L/576)	--	1.0 D + 1.0 L (All Spans)
Total Load Defl. (in)	0.464 @ 7' 6 1/2"	0.712	Passed (L/369)	--	1.0 D + 1.0 L (All Spans)

Member Length : 14' 3"
 System : Floor
 Member Type : Flush Beam
 Building Use : Residential
 Building Code : IBC 2021
 Design Methodology : ASD

- Deflection criteria: LL (L/480) and TL (L/240).
- Allowed moment does not reflect the adjustment for the beam stability factor.
- -526 lbs uplift at support located at 5 1/2". Strapping or other restraint may be required.

Supports	Bearing Length			Loads to Supports (lbs)				Accessories
	Total	Available	Required	Dead	Floor Live	Seismic	Factored	
1 - Hanger on Single 2X HF plate	5.50"	Hanger ¹	1.90"	1484	2427	2023/-202 ₃	4366/-526	See note ¹
2 - Hanger on 11 7/8" PSL beam	5.50"	Hanger ¹	2.23"	1107	2427	4023/-402 ₃	5040/-2152	See note ¹

- At hanger supports, the Total Bearing dimension is equal to the width of the material that is supporting the hanger
- ¹ See Connector grid below for additional information and/or requirements.

Lateral Bracing	Bracing Intervals	Comments
Top Edge (Lu)	14' 3" o/c	
Bottom Edge (Lu)	14' 3" o/c	

•Maximum allowable bracing intervals based on applied load.

Connector: Simpson Strong-Tie						
Support	Model	Seat Length	Top Fasteners	Face Fasteners	Member Fasteners	Accessories
1 - Top Mount Hanger	Connector not found	N/A	N/A	N/A	N/A	
2 - Face Mount Hanger	HHUS410	3.00"	N/A	30-10d	10-10d	

• Refer to manufacturer notes and instructions for proper installation and use of all connectors.

Vertical Loads	Location (Side)	Tributary Width	Dead (0.90)	Floor Live (1.00)	Seismic (1.60)	Comments
0 - Self Weight (PLF)	5 1/2" to 14' 8 1/2"	N/A	13.0	--	--	
1 - Uniform (PSF)	0 to 15' 2" (Front)	1'	12.0	40.0	-	Floor Load
2 - Uniform (PLF)	0 to 9' 6" (Top)	N/A	100.0	-	-	Wall Load Above
3 - Uniform (PSF)	0 to 15' 2" (Top)	7'	12.0	40.0	-	2nd floor load
4 - Point (lb)	9' (Top)	N/A	-	-	9500	EQ = 3800 * 2.5
5 - Point (lb)	12' 6" (Top)	N/A	-	-	-11500	EQ = 4600 * 2.5

• Side loads are assumed to not induce cross-grain tension.

ForteWEB Software Operator	Job Notes
Harrison Kliegl L120 Engineering (425) 636-3313 hkliegl@l120engineering.com	



8/23/2024 3:55:53 AM UTC
 ForteWEB v3.8, Engine: V8.4.1.24, Data: V8.1.6.3
 File Name: Granbois Residence

Weyerhaeuser Notes

Weyerhaeuser warrants that the sizing of its products will be in accordance with Weyerhaeuser product design criteria and published design values. Weyerhaeuser expressly disclaims any other warranties related to the software. Use of this software is not intended to circumvent the need for a design professional as determined by the authority having jurisdiction. The designer of record, builder or framer is responsible to assure that this calculation is compatible with the overall project. Accessories (Rim Board, Blocking Panels and Squash Blocks) are not designed by this software. Products manufactured at Weyerhaeuser facilities are third-party certified to sustainable forestry standards. Weyerhaeuser Engineered Lumber Products have been evaluated by ICC-ES under evaluation reports ESR-1153 and ESR-1387 and/or tested in accordance with applicable ASTM standards. For current code evaluation reports, Weyerhaeuser product literature and installation details refer to www.weyerhaeuser.com/woodproducts/document-library.

The product application, input design loads, dimensions and support information have been provided by ForteWEB Software Operator

ForteWEB Software Operator	Job Notes
Harrison Kliegl L120 Engineering (425) 636-3313 hkliegl@l120engineering.com	



1st Floor, 1B-2

1 piece(s) 5 1/4" x 11 7/8" 2.2E Parallam® PSL

An excessive uplift of -3559 lbs at support located at 5 1/2" failed this product.

An excessive uplift of -5311 lbs at support located at 16' 11 1/2" failed this product.

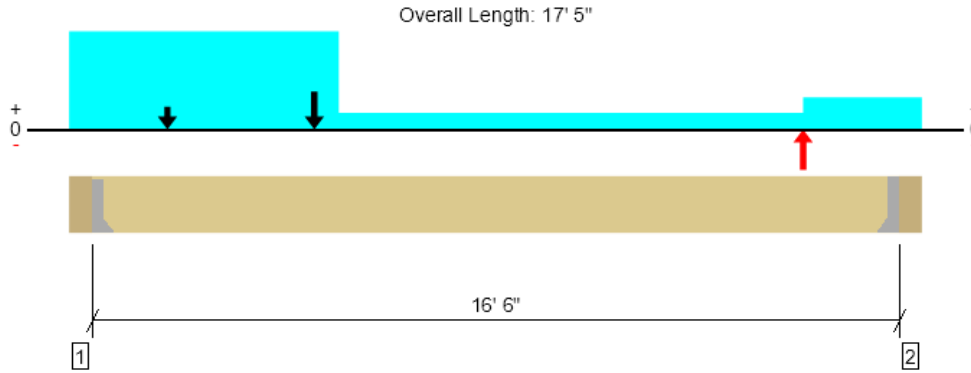

Drawing is Conceptual. All locations are measured from the outside face of left support (or left cantilever end). All dimensions are horizontal (typ.).

Design Results	Actual @ Location	Allowed	Result	LDF	Load: Combination (Pattern)
Member Reaction (lbs)	8505 @ 5 1/2"	8505 (2.59")	Passed (100%)	--	1.0 D + 0.525 E + 0.75 L + 0.75 S (All Spans)
Shear (lbs)	5322 @ 1' 5 3/8"	12053	Passed (44%)	1.00	1.0 D + 1.0 L (All Spans)
Moment (Ft-lbs)	25744 @ 5'	47766	Passed (54%)	1.60	1.0 D + 0.525 E + 0.75 L + 0.75 S (All Spans)
Live Load Defl. (in)	0.228 @ 8' 7/16"	0.412	Passed (L/869)	--	1.0 D + 1.0 L (All Spans)
Total Load Defl. (in)	0.346 @ 8' 7/8"	0.825	Passed (L/571)	--	1.0 D + 1.0 L (All Spans)

Member Length : 16' 6"
 System : Floor
 Member Type : Flush Beam
 Building Use : Residential
 Building Code : IBC 2021
 Design Methodology : ASD

- Deflection criteria: LL (L/480) and TL (L/240).
- Allowed moment does not reflect the adjustment for the beam stability factor.

Supports	Bearing Length			Loads to Supports (lbs)				Accessories
	Total	Available	Required	Dead	Floor Live	Seismic	Factored	
1 - Hanger on 11 7/8" PSL beam	5.50"	Hanger ¹	2.59"	1992	4247	6792/-6792	8743/-3559	See note ¹
2 - Hanger on 11 7/8" PSL beam	5.50"	Hanger ¹	2.00"	821	1153	8292/-8292	6625/-5311	See note ¹

- At hanger supports, the Total Bearing dimension is equal to the width of the material that is supporting the hanger
- ¹ See Connector grid below for additional information and/or requirements.

Lateral Bracing	Bracing Intervals	Comments
Top Edge (Lu)	16' 6" o/c	
Bottom Edge (Lu)	16' 6" o/c	

•Maximum allowable bracing intervals based on applied load.

Connector: Simpson Strong-Tie							
Support	Model	Seat Length	Top Fasteners	Face Fasteners	Member Fasteners	Accessories	
1 - Face Mount Hanger	HGUS5.50/10	4.00"	N/A	46-16d	16-16d		
2 - Face Mount Hanger	UA12 W=5.375	2.06"	N/A	18-SDS25300	12-SDS25300		

• Refer to manufacturer notes and instructions for proper installation and use of all connectors.

Vertical Loads	Location (Side)	Tributary Width	Dead (0.90)	Floor Live (1.00)	Seismic (1.60)	Comments
0 - Self Weight (PLF)	5 1/2" to 16' 11 1/2"	N/A	19.5	--	--	
1 - Uniform (PSF)	0 to 17' 5" (Front)	2'	12.0	40.0	-	Floor Load
2 - Uniform (PLF)	0 to 5' 6" (Top)	N/A	100.0	-	-	Wall load above
3 - Uniform (PSF)	0 to 5' 6" (Top)	8'	12.0	40.0	-	2nd floor load
4 - Point (lb)	15' (Top)	N/A	-	-	-13000	EQ = 5200 * 2.5
5 - Point (lb)	5' (Top)	N/A	-	-	11500	EQ = 4600 * 2.5
6 - Uniform (PLF)	15' to 17' 5" (Top)	N/A	100.0	-	-	wall load above
7 - Point (lb)	2' (Back)	N/A	754	2247	-	Linked from: 1B-9,

ForteWEB Software Operator	Job Notes
Harrison Kliegl L120 Engineering (425) 636-3313 hkliegl@l120engineering.com	



8/23/2024 3:55:53 AM UTC
 ForteWEB v3.8, Engine: V8.4.1.24, Data: V8.1.6.3
 File Name: Granbois Residence

- Side loads are assumed to not induce cross-grain tension.

Weyerhaeuser Notes

Weyerhaeuser warrants that the sizing of its products will be in accordance with Weyerhaeuser product design criteria and published design values. Weyerhaeuser expressly disclaims any other warranties related to the software. Use of this software is not intended to circumvent the need for a design professional as determined by the authority having jurisdiction. The designer of record, builder or framer is responsible to assure that this calculation is compatible with the overall project. Accessories (Rim Board, Blocking Panels and Squash Blocks) are not designed by this software. Products manufactured at Weyerhaeuser facilities are third-party certified to sustainable forestry standards. Weyerhaeuser Engineered Lumber Products have been evaluated by ICC-ES under evaluation reports ESR-1153 and ESR-1387 and/or tested in accordance with applicable ASTM standards. For current code evaluation reports, Weyerhaeuser product literature and installation details refer to www.eyerhaeuser.com/woodproducts/document-library.

The product application, input design loads, dimensions and support information have been provided by ForteWEB Software Operator

ForteWEB Software Operator	Job Notes
Harrison Kliegl L120 Engineering (425) 636-3313 hkliegl@l120engineering.com	



1st Floor, 1B-3

1 piece(s) 5 1/4" x 11 7/8" 2.2E Parallam® PSL

An excessive uplift of -5729 lbs at support located at 5 1/2" failed this product.

An excessive uplift of -1777 lbs at support located at 8' 11 1/2" failed this product.

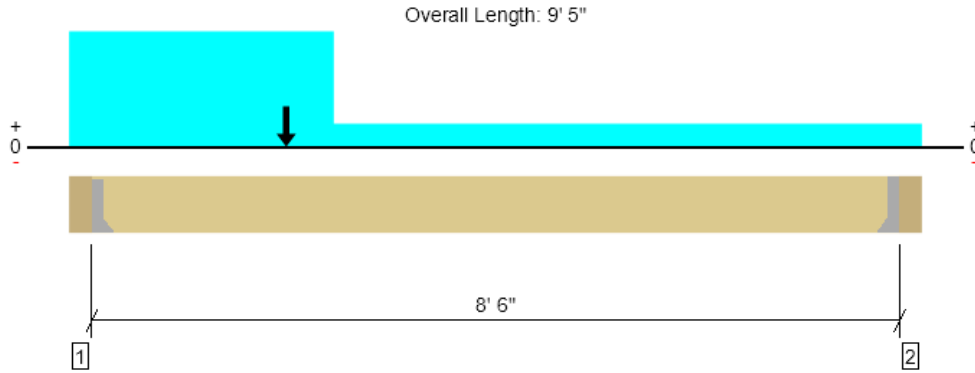

Drawing is Conceptual. All locations are measured from the outside face of left support (or left cantilever end). All dimensions are horizontal (typ.).

Design Results	Actual @ Location	Allowed	Result	LDF	Load: Combination (Pattern)
Member Reaction (lbs)	6673 @ 5 1/2"	6673 (2.03")	Passed (100%)	--	1.0 D + 0.7 E (All Spans)
Shear (lbs)	6460 @ 1' 5 3/8"	19285	Passed (33%)	1.60	1.0 D + 0.7 E (All Spans)
Moment (Ft-lbs)	13175 @ 2' 6"	47766	Passed (28%)	1.60	1.0 D + 0.7 E (All Spans)
Live Load Defl. (in)	0.011 @ 4' 6 1/8"	0.213	Passed (L/999+)	--	1.0 D + 1.0 L (All Spans)
Total Load Defl. (in)	0.018 @ 4' 5 15/16"	0.425	Passed (L/999+)	--	1.0 D + 1.0 L (All Spans)

Member Length : 8' 6"
 System : Floor
 Member Type : Flush Beam
 Building Use : Residential
 Building Code : IBC 2021
 Design Methodology : ASD

- Deflection criteria: LL (L/480) and TL (L/240).
- Allowed moment does not reflect the adjustment for the beam stability factor.

Supports	Bearing Length			Loads to Supports (lbs)				Accessories
	Total	Available	Required	Dead	Floor Live	Seismic	Factored	
1 - Hanger on 11 7/8" PSL beam	5.50"	Hanger ¹	2.03"	646	1005	8738/-8738	6763/-5729	See note ¹
2 - Hanger on 11 7/8" PSL beam	5.50"	Hanger ¹	1.50"	261	468	2762/-2762	2195/-1777	See note ¹

- At hanger supports, the Total Bearing dimension is equal to the width of the material that is supporting the hanger
- ¹ See Connector grid below for additional information and/or requirements.

Lateral Bracing	Bracing Intervals	Comments
Top Edge (Lu)	8' 6" o/c	
Bottom Edge (Lu)	8' 6" o/c	

- Maximum allowable bracing intervals based on applied load.

Connector: Simpson Strong-Tie							
Support	Model	Seat Length	Top Fasteners	Face Fasteners	Member Fasteners	Accessories	
1 - Face Mount Hanger	MGU5.50-SDS H=11.813	4.50"	N/A	24-SDS25212	16-SDS25212		
2 - Face Mount Hanger	HHUS5.50/10	3.00"	N/A	30-10d	10-10d		

- Refer to manufacturer notes and instructions for proper installation and use of all connectors.

Vertical Loads	Location (Side)	Tributary Width	Dead (0.90)	Floor Live (1.00)	Seismic (1.60)	Comments
0 - Self Weight (PLF)	5 1/2" to 8' 11 1/2"	N/A	19.5	--	--	
1 - Uniform (PSF)	0 to 9' 5" (Front)	2'	12.0	40.0	-	Floor Load
2 - Uniform (PLF)	0 to 3' (Top)	N/A	100.0	-	-	Wall load above
3 - Uniform (PSF)	0 to 3' (Top)	6'	12.0	40.0	-	2nd floor load
4 - Point (lb)	2' 6" (Top)	N/A	-	-	11500	EQ = 4600 * 2.5

- Side loads are assumed to not induce cross-grain tension.

Forteweb Software Operator	Job Notes
Harrison Kliegl L120 Engineering (425) 636-3313 hkliegl@l120engineering.com	



8/23/2024 3:55:53 AM UTC
 Forteweb v3.8, Engine: V8.4.1.24, Data: V8.1.6.3
 File Name: Granbois Residence

Weyerhaeuser Notes

Weyerhaeuser warrants that the sizing of its products will be in accordance with Weyerhaeuser product design criteria and published design values. Weyerhaeuser expressly disclaims any other warranties related to the software. Use of this software is not intended to circumvent the need for a design professional as determined by the authority having jurisdiction. The designer of record, builder or framer is responsible to assure that this calculation is compatible with the overall project. Accessories (Rim Board, Blocking Panels and Squash Blocks) are not designed by this software. Products manufactured at Weyerhaeuser facilities are third-party certified to sustainable forestry standards. Weyerhaeuser Engineered Lumber Products have been evaluated by ICC-ES under evaluation reports ESR-1153 and ESR-1387 and/or tested in accordance with applicable ASTM standards. For current code evaluation reports, Weyerhaeuser product literature and installation details refer to www.weyerhaeuser.com/woodproducts/document-library.

The product application, input design loads, dimensions and support information have been provided by ForteWEB Software Operator

ForteWEB Software Operator	Job Notes
Harrison Kliegl L120 Engineering (425) 636-3313 hkliegl@l120engineering.com	



1st Floor, 1B-4

1 piece(s) 5 1/4" x 11 7/8" 2.2E Parallam® PSL

An excessive uplift of -5500 lbs at support located at 3' 1" failed this product.

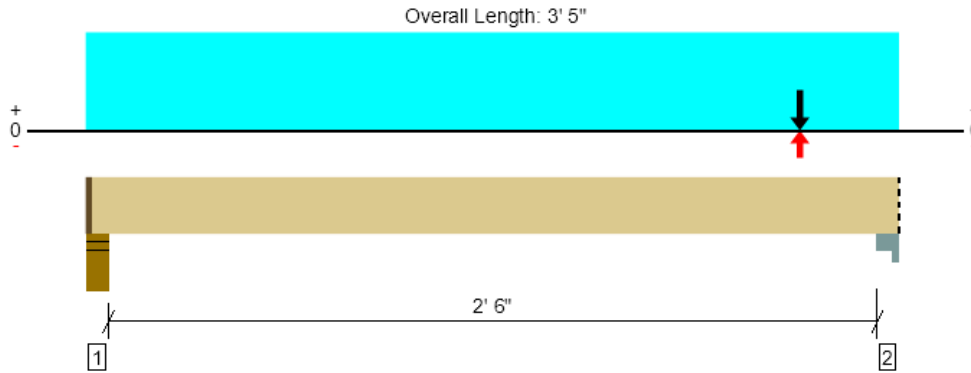

Drawing is Conceptual. All locations are measured from the outside face of left support (or left cantilever end). All dimensions are horizontal (typ.).

Design Results	Actual @ Location	Allowed	Result	LDf	Load: Combination (Pattern) [Group]
Member Reaction (lbs)	14928 @ 3' 1"	18047 (5.50")	Passed (83%)	--	1.0 D + 0.525 E + 0.75 L + 0.75 S (All Spans) [1]
Shear (lbs)	215 @ 1' 5 3/8"	12053	Passed (2%)	1.00	1.0 D + 1.0 L (All Spans) [1]
Moment (Ft-lbs)	780 @ 1' 8 1/2"	29854	Passed (3%)	1.00	1.0 D + 1.0 L (All Spans) [1]
Live Load Defl. (in)	0.001 @ 1' 8 1/2"	0.069	Passed (L/999+)	--	1.0 D + 1.0 L (All Spans) [1]
Total Load Defl. (in)	0.002 @ 1' 8 1/2"	0.138	Passed (L/999+)	--	1.0 D + 1.0 L (All Spans) [1]

Member Length : 3' 3 1/2"
 System : Floor
 Member Type : Flush Beam
 Building Use : Residential
 Building Code : IBC 2021
 Design Methodology : ASD

- Deflection criteria: LL (L/480) and TL (L/240).
- Allowed moment does not reflect the adjustment for the beam stability factor.

Supports	Bearing Length			Loads to Supports (lbs)				Accessories
	Total	Available	Required	Dead	Floor Live	Seismic	Factored	
1 - Stud wall - HF	5.50"	4.00"	1.50"	349	1059	-	1408	1 1/2" Rim Board
2 - Column Cap - steel	5.50"	5.50"	4.55"	3450	7733	10815/-10815	14928/-5500	Blocking

- Rim Board is assumed to carry all loads applied directly above it, bypassing the member being designed.
- Blocking Panels are assumed to carry no loads applied directly above them and the full load is applied to the member being designed.

Lateral Bracing	Bracing Intervals	Comments
Top Edge (Lu)	3' 4" o/c	
Bottom Edge (Lu)	3' 4" o/c	

- Maximum allowable bracing intervals based on applied load.

Vertical Loads	Location (Side)	Tributary Width	Dead (0.90)	Floor Live (1.00)	Seismic (1.60)	Comments
0 - Self Weight (PLF)	1 1/2" to 3' 5"	N/A	19.5	--	--	
1 - Uniform (PSF)	0 to 3' 5" (Front)	15' 6"	12.0	40.0	-	Floor Load
2 - Point (lb)	3' (Front)	N/A	1107	2427	4023/-4023	Linked from: 1B-1, Support 2
3 - Point (lb)	3' (Back)	N/A	1992	4247	6792/-6792	Linked from: 1B-2, Support 1

- Side loads are assumed to not induce cross-grain tension.

Weyerhaeuser Notes

Weyerhaeuser warrants that the sizing of its products will be in accordance with Weyerhaeuser product design criteria and published design values. Weyerhaeuser expressly disclaims any other warranties related to the software. Use of this software is not intended to circumvent the need for a design professional as determined by the authority having jurisdiction. The designer of record, builder or framer is responsible to assure that this calculation is compatible with the overall project. Accessories (Rim Board, Blocking Panels and Squash Blocks) are not designed by this software. Products manufactured at Weyerhaeuser facilities are third-party certified to sustainable forestry standards. Weyerhaeuser Engineered Lumber Products have been evaluated by ICC-ES under evaluation reports ESR-1153 and ESR-1387 and/or tested in accordance with applicable ASTM standards. For current code evaluation reports, Weyerhaeuser product literature and installation details refer to www.weyerhaeuser.com/woodproducts/document-library.

The product application, input design loads, dimensions and support information have been provided by ForteWEB Software Operator

ForteWEB Software Operator	Job Notes
Harrison Kliegl L120 Engineering (425) 636-3313 hkliegl@l120engineering.com	



8/23/2024 3:55:53 AM UTC
 ForteWEB v3.8, Engine: V8.4.1.24, Data: V8.1.6.3
 File Name: Granbois Residence

1st Floor, 1B-5

1 piece(s) 7" x 16" 2.2E Parallam® PSL

An excessive uplift of -1538 lbs at support located at 5 1/2" failed this product.

An excessive uplift of -4879 lbs at support located at 17' 1" failed this product.

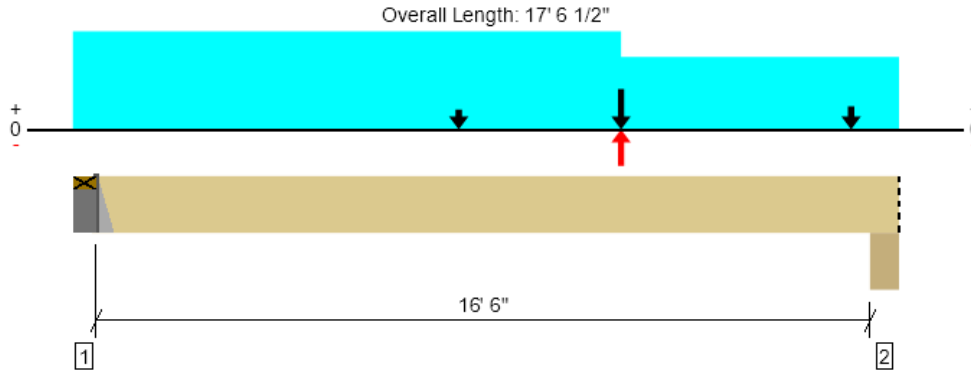

Drawing is Conceptual. All locations are measured from the outside face of left support (or left cantilever end). All dimensions are horizontal (typ.).

Design Results	Actual @ Location	Allowed	Result	LDF	Load: Combination (Pattern) [Group]
Member Reaction (lbs)	11758 @ 5 1/2"	11758 (2.69")	Passed (100%)	--	1.0 D + 0.525 E + 0.75 L + 0.75 S (All Spans) [1]
Shear (lbs)	10531 @ 15' 7 1/2"	21653	Passed (49%)	1.00	1.0 D + 1.0 L (All Spans) [1]
Moment (Ft-lbs)	48659 @ 9' 1 11/16"	69909	Passed (70%)	1.00	1.0 D + 1.0 L (All Spans) [1]
Live Load Defl. (in)	0.305 @ 8' 11 1/4"	0.416	Passed (L/654)	--	1.0 D + 1.0 L (All Spans) [1]
Total Load Defl. (in)	0.500 @ 8' 10 13/16"	0.831	Passed (L/399)	--	1.0 D + 1.0 L (All Spans) [1]

Member Length : 17' 1"
 System : Floor
 Member Type : Flush Beam
 Building Use : Residential
 Building Code : IBC 2021
 Design Methodology : ASD

- Deflection criteria: LL (L/480) and TL (L/240).
- Allowed moment does not reflect the adjustment for the beam stability factor.
- Member should be side-loaded from both sides of the member or braced to prevent rotation.

Supports	Bearing Length			Loads to Supports (lbs)					Accessories
	Total	Available	Required	Dead	Floor Live	Snow	Seismic	Factored	
1 - Hanger on Single 2X HF plate	5.50"	Hanger ¹	2.69"	4110	6069	599	5719/-571 ₉	12114/-153 ₈	See note ¹
2 - Column - PSL	7.00"	7.00"	4.29"	5064	10011	356	11311/-11 ₃₁₁	18777/-487 ₉	Blocking

- Blocking Panels are assumed to carry no loads applied directly above them and the full load is applied to the member being designed.
- At hanger supports, the Total Bearing dimension is equal to the width of the material that is supporting the hanger
- ¹ See Connector grid below for additional information and/or requirements.

Lateral Bracing	Bracing Intervals	Comments
Top Edge (Lu)	17' 1" o/c	
Bottom Edge (Lu)	17' 1" o/c	

•Maximum allowable bracing intervals based on applied load.

Connector: Simpson Strong-Tie						
Support	Model	Seat Length	Top Fasteners	Face Fasteners	Member Fasteners	Accessories
1 - Top Mount Hanger	Connector not found	N/A	N/A	N/A	N/A	

- Refer to manufacturer notes and instructions for proper installation and use of all connectors.

ForteWEB Software Operator	Job Notes
Harrison Kliegl L120 Engineering (425) 636-3313 hkliegl@l120engineering.com	



Vertical Loads	Location (Side)	Tributary Width	Dead (0.90)	Floor Live (1.00)	Snow (1.15)	Seismic (1.60)	Comments
0 - Self Weight (PLF)	5 1/2" to 17' 6 1/2"	N/A	35.0	--	--	--	
1 - Uniform (PSF)	0 to 17' 6 1/2" (Front)	13'	12.0	40.0	-	-	Floor Load
2 - Uniform (PLF)	0 to 11' 6" (Top)	N/A	160.0	-	-	-	2 levels wall load above
3 - Uniform (PSF)	0 to 11' 6" (Top)	2'	16.2	-	25.0	-	Roof Load Above
4 - Point (lb)	8' (Top)	N/A	732	1203	380	-	Linked from: 2B-16, Support 1
5 - Point (lb)	11' 6" (Back)	N/A	821	1153	-	8292/-8292	Linked from: 1B-2, Support 2
6 - Point (lb)	11' 6" (Front)	N/A	646	1005	-	8738/-8738	Linked from: 1B-3, Support 1
7 - Point (lb)	16' 6" (Front)	N/A	1427	3597	-	-	Linked from: 1B-11, Support 1

• Side loads are assumed to not induce cross-grain tension.

Weyerhaeuser Notes

Weyerhaeuser warrants that the sizing of its products will be in accordance with Weyerhaeuser product design criteria and published design values. Weyerhaeuser expressly disclaims any other warranties related to the software. Use of this software is not intended to circumvent the need for a design professional as determined by the authority having jurisdiction. The designer of record, builder or framer is responsible to assure that this calculation is compatible with the overall project. Accessories (Rim Board, Blocking Panels and Squash Blocks) are not designed by this software. Products manufactured at Weyerhaeuser facilities are third-party certified to sustainable forestry standards. Weyerhaeuser Engineered Lumber Products have been evaluated by ICC-ES under evaluation reports ESR-1153 and ESR-1387 and/or tested in accordance with applicable ASTM standards. For current code evaluation reports, Weyerhaeuser product literature and installation details refer to www.weyerhaeuser.com/woodproducts/document-library.

The product application, input design loads, dimensions and support information have been provided by ForteWEB Software Operator

ForteWEB Software Operator	Job Notes
Harrison Kliegl L120 Engineering (425) 636-3313 hkliegl@l120engineering.com	



8/23/2024 3:55:53 AM UTC
ForteWEB v3.8, Engine: V8.4.1.24, Data: V8.1.6.3
File Name: Granbois Residence

1st Floor, 1B-6

1 piece(s) 5 1/4" x 11 7/8" 2.2E Parallam® PSL

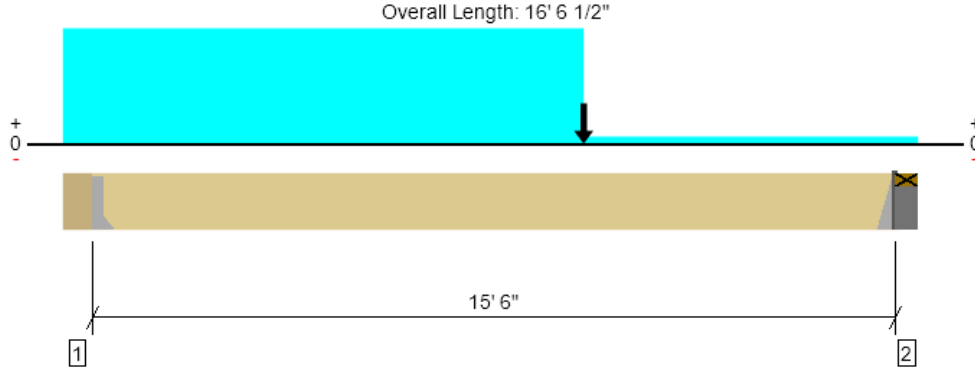

Drawing is Conceptual. All locations are measured from the outside face of left support (or left cantilever end). All dimensions are horizontal (typ.).

Design Results	Actual @ Location	Allowed	Result	LDF	Load: Combination (Pattern)
Member Reaction (lbs)	5700 @ 7"	5700 (1.74")	Passed (100%)	--	1.0 D + 1.0 L (All Spans)
Shear (lbs)	4967 @ 1' 6 7/8"	12053	Passed (41%)	1.00	1.0 D + 1.0 L (All Spans)
Moment (Ft-lbs)	21937 @ 8' 3 3/8"	29854	Passed (73%)	1.00	1.0 D + 1.0 L (All Spans)
Live Load Defl. (in)	0.346 @ 8' 2 3/4"	0.387	Passed (L/537)	--	1.0 D + 1.0 L (All Spans)
Total Load Defl. (in)	0.605 @ 8' 2 9/16"	0.775	Passed (L/307)	--	1.0 D + 1.0 L (All Spans)

Member Length : 15' 6"
 System : Floor
 Member Type : Flush Beam
 Building Use : Residential
 Building Code : IBC 2021
 Design Methodology : ASD

- Deflection criteria: LL (L/480) and TL (L/240).
- Allowed moment does not reflect the adjustment for the beam stability factor.

Supports	Bearing Length			Loads to Supports (lbs)				Accessories
	Total	Available	Required	Dead	Floor Live	Snow	Factored	
1 - Hanger on 11 7/8" PSL beam	7.00"	Hanger ¹	1.74"	2674	3447	984	6121	See note ¹
2 - Hanger on Single 2X HF plate	5.50"	Hanger ¹	1.50"	1550	2118	565	3667	See note ¹

- At hanger supports, the Total Bearing dimension is equal to the width of the material that is supporting the hanger
- ¹ See Connector grid below for additional information and/or requirements.

Lateral Bracing	Bracing Intervals	Comments
Top Edge (Lu)	15' 6" o/c	
Bottom Edge (Lu)	15' 6" o/c	

- Maximum allowable bracing intervals based on applied load.

Connector: Simpson Strong-Tie						
Support	Model	Seat Length	Top Fasteners	Face Fasteners	Member Fasteners	Accessories
1 - Face Mount Hanger	HGUS5.50/10	4.00"	N/A	46-10d	16-10d	
2 - Top Mount Hanger	Connector not found	N/A	N/A	N/A	N/A	

- Refer to manufacturer notes and instructions for proper installation and use of all connectors.

Vertical Loads	Location (Side)	Tributary Width	Dead (0.90)	Floor Live (1.00)	Snow (1.15)	Comments
0 - Self Weight (PLF)	7" to 16' 1"	N/A	19.5	--	--	
1 - Uniform (PSF)	0 to 16' 6 1/2" (Front)	1'	12.0	40.0	-	Floor Load
2 - Uniform (PLF)	0 to 10' (Top)	N/A	80.0	-	-	Wall load above
3 - Uniform (PSF)	0 to 10' (Top)	3'	12.0	40.0	-	2nd floor load
4 - Uniform (PLF)	0 to 10' (Top)	N/A	183.1	250.0	116.9	Linked from: 2J-2, Support 1
5 - Point (lb)	10' (Top)	N/A	732	1203	380	Linked from: 2B-16, Support 1

- Side loads are assumed to not induce cross-grain tension.

Forteweb Software Operator	Job Notes
Harrison Kliegl L120 Engineering (425) 636-3313 hkliegl@l120engineering.com	



Weyerhaeuser Notes

Weyerhaeuser warrants that the sizing of its products will be in accordance with Weyerhaeuser product design criteria and published design values. Weyerhaeuser expressly disclaims any other warranties related to the software. Use of this software is not intended to circumvent the need for a design professional as determined by the authority having jurisdiction. The designer of record, builder or framer is responsible to assure that this calculation is compatible with the overall project. Accessories (Rim Board, Blocking Panels and Squash Blocks) are not designed by this software. Products manufactured at Weyerhaeuser facilities are third-party certified to sustainable forestry standards. Weyerhaeuser Engineered Lumber Products have been evaluated by ICC-ES under evaluation reports ESR-1153 and ESR-1387 and/or tested in accordance with applicable ASTM standards. For current code evaluation reports, Weyerhaeuser product literature and installation details refer to www.weyerhaeuser.com/woodproducts/document-library.

The product application, input design loads, dimensions and support information have been provided by ForteWEB Software Operator

ForteWEB Software Operator	Job Notes
Harrison Kliegl L120 Engineering (425) 636-3313 hkliegl@l120engineering.com	



1st Floor, 1B-7

1 piece(s) 7" x 16" 2.2E Parallam® PSL

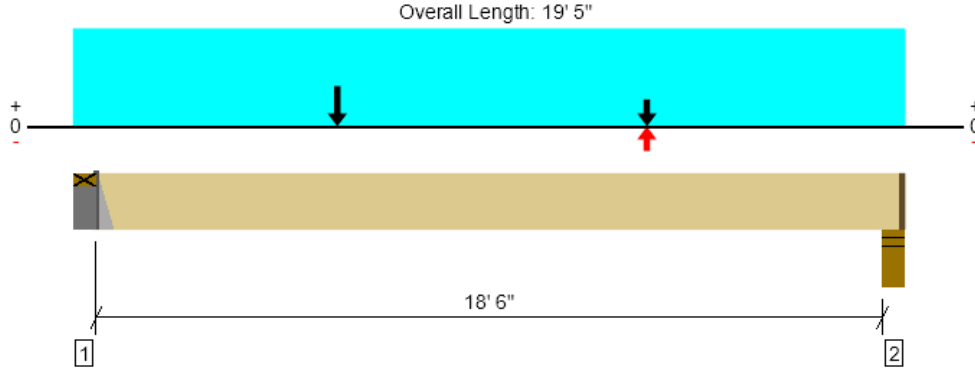

Drawing is Conceptual. All locations are measured from the outside face of left support (or left cantilever end). All dimensions are horizontal (typ.).

Design Results	Actual @ Location	Allowed	Result	LDF	Load: Combination (Pattern) [Group]
Member Reaction (lbs)	10907 @ 5 1/2"	10907 (2.49")	Passed (100%)	--	1.0 D + 1.0 L (All Spans) [8]
Shear (lbs)	9994 @ 1' 9 1/2"	21653	Passed (46%)	1.00	1.0 D + 1.0 L (All Spans) [1]
Moment (Ft-lbs)	50641 @ 7' 5 3/8"	69909	Passed (72%)	1.00	1.0 D + 1.0 L (All Spans) [1]
Live Load Defl. (in)	0.426 @ 9' 6 5/16"	0.466	Passed (L/525)	--	1.0 D + 1.0 L (All Spans) [1]
Total Load Defl. (in)	0.639 @ 9' 5 11/16"	0.931	Passed (L/350)	--	1.0 D + 1.0 L (All Spans) [1]

Member Length : 18' 10"
 System : Floor
 Member Type : Flush Beam
 Building Use : Residential
 Building Code : IBC 2021
 Design Methodology : ASD

- Deflection criteria: LL (L/480) and TL (L/240).
- Allowed moment does not reflect the adjustment for the beam stability factor.
- Member should be side-loaded from both sides of the member or braced to prevent rotation.

Supports	Bearing Length			Loads to Supports (lbs)					Accessories
	Total	Available	Required	Dead	Floor Live	Snow	Seismic	Factored	
1 - Hanger on Single 2X HF plate	5.50"	Hanger ¹	2.49"	3752	7453	691	865/-865	11205	See note ¹
2 - Stud wall - HF	5.50"	4.00"	3.12"	2755	6170	293	1897/-1897	8925	1 1/2" Rim Board

- Rim Board is assumed to carry all loads applied directly above it, bypassing the member being designed.
- At hanger supports, the Total Bearing dimension is equal to the width of the material that is supporting the hanger
- ¹ See Connector grid below for additional information and/or requirements.

Lateral Bracing	Bracing Intervals	Comments
Top Edge (Lu)	18' 10" o/c	
Bottom Edge (Lu)	18' 10" o/c	

•Maximum allowable bracing intervals based on applied load.

Connector: Simpson Strong-Tie						
Support	Model	Seat Length	Top Fasteners	Face Fasteners	Member Fasteners	Accessories
1 - Top Mount Hanger	Connector not found	N/A	N/A	N/A	N/A	

• Refer to manufacturer notes and instructions for proper installation and use of all connectors.

Vertical Loads	Location (Side)	Tributary Width	Dead (0.90)	Floor Live (1.00)	Snow (1.15)	Seismic (1.60)	Comments
0 - Self Weight (PLF)	5 1/2" to 19' 3 1/2"	N/A	35.0	--	--	--	
1 - Uniform (PSF)	0 to 19' 5" (Front)	12' 6"	12.0	40.0	-	-	Floor Load
2 - Point (lb)	13' 3" (Back)	N/A	261	468	-	2762/-2762	Linked from: 1B-3, Support 2
3 - Point (lb)	6' (Front)	N/A	2674	3447	984	-	Linked from: 1B-6, Support 1

• Side loads are assumed to not induce cross-grain tension.

Forteweb Software Operator	Job Notes
Harrison Kliegl L120 Engineering (425) 636-3313 hkliegl@l120engineering.com	



Weyerhaeuser Notes

Weyerhaeuser warrants that the sizing of its products will be in accordance with Weyerhaeuser product design criteria and published design values. Weyerhaeuser expressly disclaims any other warranties related to the software. Use of this software is not intended to circumvent the need for a design professional as determined by the authority having jurisdiction. The designer of record, builder or framer is responsible to assure that this calculation is compatible with the overall project. Accessories (Rim Board, Blocking Panels and Squash Blocks) are not designed by this software. Products manufactured at Weyerhaeuser facilities are third-party certified to sustainable forestry standards. Weyerhaeuser Engineered Lumber Products have been evaluated by ICC-ES under evaluation reports ESR-1153 and ESR-1387 and/or tested in accordance with applicable ASTM standards. For current code evaluation reports, Weyerhaeuser product literature and installation details refer to www.weyerhaeuser.com/woodproducts/document-library.

The product application, input design loads, dimensions and support information have been provided by ForteWEB Software Operator

ForteWEB Software Operator	Job Notes
Harrison Kliegl L120 Engineering (425) 636-3313 hkliegl@l120engineering.com	



1st Floor, 1B-8 (Beam over window well)
1 piece(s) 5 1/4" x 11 7/8" 2.2E Parallam® PSL

An excessive uplift of -5771 lbs at support located at 9' 5 1/2" failed this product.

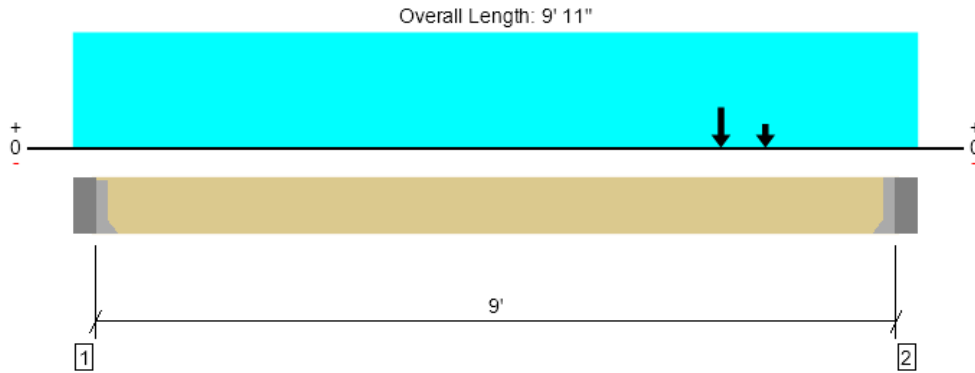

Drawing is Conceptual. All locations are measured from the outside face of left support (or left cantilever end). All dimensions are horizontal (typ.).

Design Results	Actual @ Location	Allowed	Result	LDF	Load: Combination (Pattern)
Member Reaction (lbs)	12443 @ 9' 5 1/2"	12443 (3.79")	Passed (100%)	--	1.0 D + 0.525 E + 0.75 L + 0.75 S (All Spans)
Shear (lbs)	11696 @ 8' 5 5/8"	19285	Passed (61%)	1.60	1.0 D + 0.525 E + 0.75 L + 0.75 S (All Spans)
Moment (Ft-lbs)	21143 @ 7' 6"	47766	Passed (44%)	1.60	1.0 D + 0.7 E (All Spans)
Live Load Defl. (in)	0.054 @ 5' 1 15/16"	0.225	Passed (L/999+)	--	1.0 D + 1.0 L (All Spans)
Total Load Defl. (in)	0.124 @ 5' 1 3/8"	0.450	Passed (L/874)	--	1.0 D + 1.0 L (All Spans)

Member Length : 9'
 System : Floor
 Member Type : Flush Beam
 Building Use : Residential
 Building Code : IBC 2021
 Design Methodology : ASD

- Deflection criteria: LL (L/480) and TL (L/240).
- Allowed moment does not reflect the adjustment for the beam stability factor.
- -568 lbs uplift at support located at 5 1/2". Strapping or other restraint may be required.

Supports	Bearing Length			Loads to Supports (lbs)					Accessories
	Total	Available	Required	Dead	Floor Live	Snow	Seismic	Factored	
1 - Hanger on concrete	5.50"	Hanger ¹	1.73"	2798	1930	92	3209/-3209	5999/-568	See note ¹
2 - Hanger on concrete	5.50"	Hanger ¹	3.79"	3846	3361	473	11541/-11541	12781/-5771	See note ¹

- At hanger supports, the Total Bearing dimension is equal to the width of the material that is supporting the hanger
- ¹ See Connector grid below for additional information and/or requirements.

Lateral Bracing	Bracing Intervals	Comments
Top Edge (Lu)	9' o/c	
Bottom Edge (Lu)	9' o/c	

•Maximum allowable bracing intervals based on applied load.

Connector: Simpson Strong-Tie

Support	Model	Seat Length	Top Fasteners	Face Fasteners	Member Fasteners	Accessories
1 - Face Mount Hanger	Connector not found	N/A	N/A	N/A	N/A	
2 - Face Mount Hanger	Connector not found	N/A	N/A	N/A	N/A	

- Refer to manufacturer notes and instructions for proper installation and use of all connectors.

Vertical Loads	Location (Side)	Tributary Width	Dead (0.90)	Floor Live (1.00)	Snow (1.15)	Seismic (1.60)	Comments
0 - Self Weight (PLF)	5 1/2" to 9' 5 1/2"	N/A	19.5	--	--	--	
1 - Uniform (PSF)	0 to 9' 11" (Front)	8'	12.0	40.0	-	-	Floor Load
2 - Point (lb)	7' 6" (Top)	N/A	-	-	-	14750	EQ = 5900 * 2.5
3 - Uniform (PLF)	0 to 9' 11" (Top)	N/A	400.0	-	-	-	wall load with brick above
4 - Point (lb)	8' (Front)	N/A	1550	2118	565	-	Linked from: 1B-6, Support 2

- Side loads are assumed to not induce cross-grain tension.

ForteWEB Software Operator	Job Notes
Harrison Kliegl L120 Engineering (425) 636-3313 hkliegl@l120engineering.com	



8/23/2024 3:55:53 AM UTC
 ForteWEB v3.8, Engine: V8.4.1.24, Data: V8.1.6.3
 File Name: Granbois Residence

Weyerhaeuser Notes

Weyerhaeuser warrants that the sizing of its products will be in accordance with Weyerhaeuser product design criteria and published design values. Weyerhaeuser expressly disclaims any other warranties related to the software. Use of this software is not intended to circumvent the need for a design professional as determined by the authority having jurisdiction. The designer of record, builder or framer is responsible to assure that this calculation is compatible with the overall project. Accessories (Rim Board, Blocking Panels and Squash Blocks) are not designed by this software. Products manufactured at Weyerhaeuser facilities are third-party certified to sustainable forestry standards. Weyerhaeuser Engineered Lumber Products have been evaluated by ICC-ES under evaluation reports ESR-1153 and ESR-1387 and/or tested in accordance with applicable ASTM standards. For current code evaluation reports, Weyerhaeuser product literature and installation details refer to www.weyerhaeuser.com/woodproducts/document-library.

The product application, input design loads, dimensions and support information have been provided by ForteWEB Software Operator

ForteWEB Software Operator	Job Notes
Harrison Kliegl L120 Engineering (425) 636-3313 hkliegl@l120engineering.com	



1st Floor, 1B-9

2 piece(s) 1 3/4" x 11 7/8" 2.0E Microllam® LVL

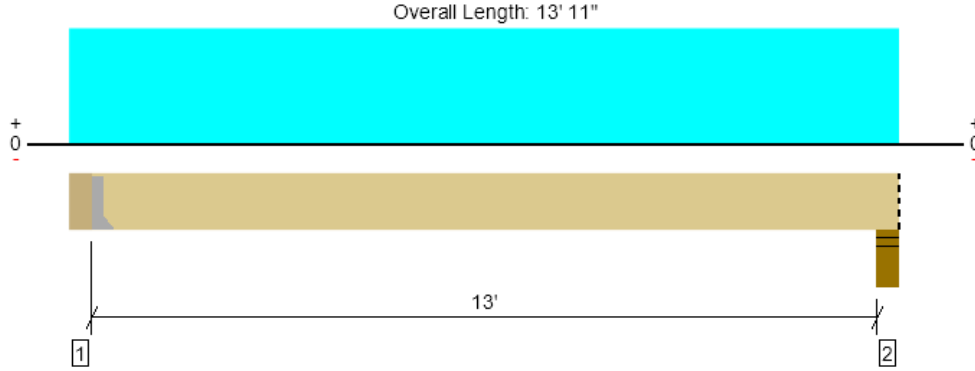

Drawing is Conceptual. All locations are measured from the outside face of left support (or left cantilever end). All dimensions are horizontal (typ.).

Design Results	Actual @ Location	Allowed	Result	LDF	Load: Combination (Pattern)
Member Reaction (lbs)	2810 @ 5 1/2"	3938 (1.50")	Passed (71%)	--	1.0 D + 1.0 L (All Spans)
Shear (lbs)	2386 @ 1' 5 3/8"	7897	Passed (30%)	1.00	1.0 D + 1.0 L (All Spans)
Moment (Ft-lbs)	9219 @ 7' 1/4"	17848	Passed (52%)	1.00	1.0 D + 1.0 L (All Spans)
Live Load Defl. (in)	0.238 @ 7' 1/4"	0.328	Passed (L/662)	--	1.0 D + 1.0 L (All Spans)
Total Load Defl. (in)	0.318 @ 7' 1/4"	0.656	Passed (L/495)	--	1.0 D + 1.0 L (All Spans)

Member Length : 13' 5 1/2"
 System : Floor
 Member Type : Flush Beam
 Building Use : Residential
 Building Code : IBC 2021
 Design Methodology : ASD

- Deflection criteria: LL (L/480) and TL (L/240).
- Allowed moment does not reflect the adjustment for the beam stability factor.

Supports	Bearing Length			Loads to Supports (lbs)			Accessories
	Total	Available	Required	Dead	Floor Live	Factored	
1 - Hanger on 11 7/8" PSL beam	5.50"	Hanger ¹	1.50"	754	2247	3000	See note ¹
2 - Stud wall - HF	5.50"	5.50"	2.08"	746	2207	2952	Blocking

- Blocking Panels are assumed to carry no loads applied directly above them and the full load is applied to the member being designed.
- At hanger supports, the Total Bearing dimension is equal to the width of the material that is supporting the hanger
- ¹ See Connector grid below for additional information and/or requirements.

Lateral Bracing	Bracing Intervals	Comments
Top Edge (Lu)	13' 6" o/c	
Bottom Edge (Lu)	13' 6" o/c	

•Maximum allowable bracing intervals based on applied load.

Connector: Simpson Strong-Tie

Support	Model	Seat Length	Top Fasteners	Face Fasteners	Member Fasteners	Accessories
1 - Face Mount Hanger	HHUS48	3.00"	N/A	22-10d	8-10d	

- Refer to manufacturer notes and instructions for proper installation and use of all connectors.

Vertical Loads	Location (Side)	Tributary Width	Dead (0.90)	Floor Live (1.00)	Comments
0 - Self Weight (PLF)	5 1/2" to 13' 11"	N/A	12.1	--	
1 - Uniform (PSF)	0 to 13' 11" (Front)	8'	12.0	40.0	Floor Load

- Side loads are assumed to not induce cross-grain tension.

Weyerhaeuser Notes

Weyerhaeuser warrants that the sizing of its products will be in accordance with Weyerhaeuser product design criteria and published design values. Weyerhaeuser expressly disclaims any other warranties related to the software. Use of this software is not intended to circumvent the need for a design professional as determined by the authority having jurisdiction. The designer of record, builder or framer is responsible to assure that this calculation is compatible with the overall project. Accessories (Rim Board, Blocking Panels and Squash Blocks) are not designed by this software. Products manufactured at Weyerhaeuser facilities are third-party certified to sustainable forestry standards. Weyerhaeuser Engineered Lumber Products have been evaluated by ICC-ES under evaluation reports ESR-1153 and ESR-1387 and/or tested in accordance with applicable ASTM standards. For current code evaluation reports, Weyerhaeuser product literature and installation details refer to www.weyerhaeuser.com/woodproducts/document-library.

The product application, input design loads, dimensions and support information have been provided by ForteWEB Software Operator

ForteWEB Software Operator	Job Notes
Harrison Kliegl L120 Engineering (425) 636-3313 hkliegl@l120engineering.com	



8/23/2024 3:55:53 AM UTC
 ForteWEB v3.8, Engine: V8.4.1.24, Data: V8.1.6.3
 File Name: Granbois Residence

1st Floor, 1B-10

1 piece(s) 7" x 14" 2.2E Parallam® PSL

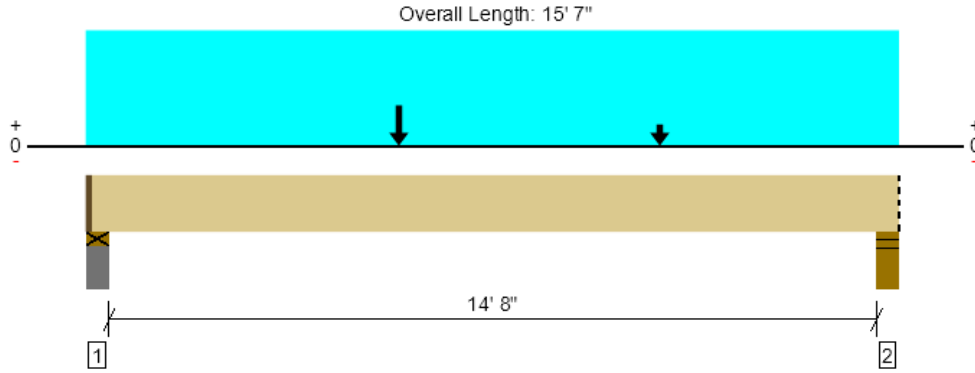

Drawing is Conceptual. All locations are measured from the outside face of left support (or left cantilever end). All dimensions are horizontal (typ.).

Design Results	Actual @ Location	Allowed	Result	LDF	Load: Combination (Pattern)
Member Reaction (lbs)	9470 @ 4"	17500 (4.00")	Passed (54%)	--	1.0 D + 0.75 L + 0.75 S (All Spans)
Shear (lbs)	8154 @ 1' 7 1/2"	18947	Passed (43%)	1.00	1.0 D + 1.0 L (All Spans)
Moment (Ft-lbs)	52410 @ 6'	62472	Passed (84%)	1.15	1.0 D + 0.75 L + 0.75 S (All Spans)
Live Load Defl. (in)	0.230 @ 7' 5 9/16"	0.373	Passed (L/779)	--	1.0 D + 0.75 L + 0.75 S (All Spans)
Total Load Defl. (in)	0.548 @ 7' 5 7/16"	0.746	Passed (L/327)	--	1.0 D + 0.75 L + 0.75 S (All Spans)

Member Length : 15' 5 1/2"
 System : Floor
 Member Type : Flush Beam
 Building Use : Residential
 Building Code : IBC 2021
 Design Methodology : ASD

- Deflection criteria: LL (L/480) and TL (L/240).
- Allowed moment does not reflect the adjustment for the beam stability factor.
- Member should be side-loaded from both sides of the member or braced to prevent rotation.

Supports	Bearing Length			Loads to Supports (lbs)				Accessories
	Total	Available	Required	Dead	Floor Live	Snow	Factored	
1 - Plate on concrete - DF	5.50"	4.00"	2.16"	5519	2766	2509	9475	1 1/2" Rim Board
2 - Stud wall - DF	5.50"	5.50"	1.65"	4174	2297	1779	7231	Blocking

- Rim Board is assumed to carry all loads applied directly above it, bypassing the member being designed.
- Blocking Panels are assumed to carry no loads applied directly above them and the full load is applied to the member being designed.

Lateral Bracing	Bracing Intervals	Comments
Top Edge (Lu)	15' 6" o/c	
Bottom Edge (Lu)	15' 6" o/c	

- Maximum allowable bracing intervals based on applied load.

Vertical Loads	Location (Side)	Tributary Width	Dead (0.90)	Floor Live (1.00)	Snow (1.15)	Comments
0 - Self Weight (PLF)	1 1/2" to 15' 7"	N/A	30.6	--	--	
1 - Uniform (PSF)	0 to 15' 7" (Front)	1'	12.0	40.0	-	Floor Load
2 - Point (lb)	6' (Top)	N/A	7807	3548	3841	Linked from: 2B-3, Support 2
3 - Point (lb)	11' (Top)	N/A	1225	892	447	Linked from: 2B-3, Support 1

- Side loads are assumed to not induce cross-grain tension.

Weyerhaeuser Notes

Weyerhaeuser warrants that the sizing of its products will be in accordance with Weyerhaeuser product design criteria and published design values. Weyerhaeuser expressly disclaims any other warranties related to the software. Use of this software is not intended to circumvent the need for a design professional as determined by the authority having jurisdiction. The designer of record, builder or framer is responsible to assure that this calculation is compatible with the overall project. Accessories (Rim Board, Blocking Panels and Squash Blocks) are not designed by this software. Products manufactured at Weyerhaeuser facilities are third-party certified to sustainable forestry standards. Weyerhaeuser Engineered Lumber Products have been evaluated by ICC-ES under evaluation reports ESR-1153 and ESR-1387 and/or tested in accordance with applicable ASTM standards. For current code evaluation reports, Weyerhaeuser product literature and installation details refer to www.weyerhaeuser.com/woodproducts/document-library.

The product application, input design loads, dimensions and support information have been provided by ForteWEB Software Operator

ForteWEB Software Operator	Job Notes
Harrison Kliegl L120 Engineering (425) 636-3313 hkliegl@l120engineering.com	



8/23/2024 3:55:53 AM UTC
 ForteWEB v3.8, Engine: V8.4.1.24, Data: V8.1.6.3
 File Name: Granbois Residence

1st Floor, 1B-11

1 piece(s) 3 1/2" x 11 7/8" 2.2E Parallam® PSL

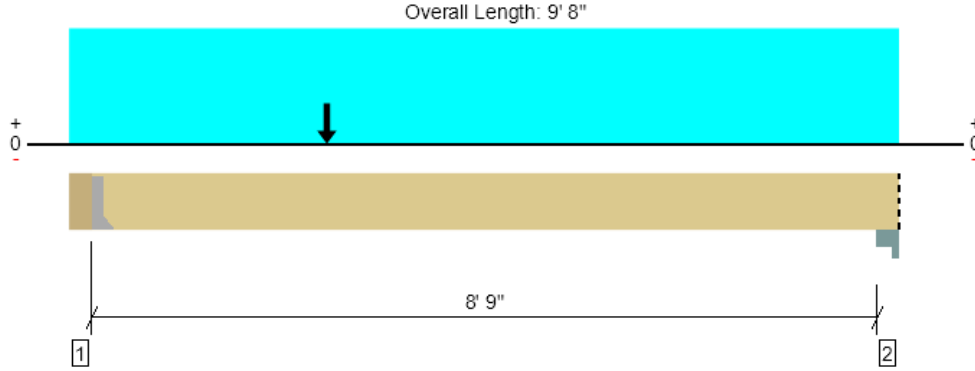

Drawing is Conceptual. All locations are measured from the outside face of left support (or left cantilever end). All dimensions are horizontal (typ.).

Design Results	Actual @ Location	Allowed	Result	LDF	Load: Combination (Pattern)
Member Reaction (lbs)	5000 @ 5 1/2"	5000 (2.29")	Passed (100%)	--	1.0 D + 1.0 L (All Spans)
Shear (lbs)	4936 @ 1' 5 3/8"	8035	Passed (61%)	1.00	1.0 D + 1.0 L (All Spans)
Moment (Ft-lbs)	12499 @ 3'	19902	Passed (63%)	1.00	1.0 D + 1.0 L (All Spans)
Live Load Defl. (in)	0.109 @ 4' 5 5/8"	0.222	Passed (L/973)	--	1.0 D + 1.0 L (All Spans)
Total Load Defl. (in)	0.153 @ 4' 5 5/8"	0.444	Passed (L/696)	--	1.0 D + 1.0 L (All Spans)

Member Length : 9' 2 1/2"
 System : Floor
 Member Type : Flush Beam
 Building Use : Residential
 Building Code : IBC 2021
 Design Methodology : ASD

- Deflection criteria: LL (L/480) and TL (L/240).
- Allowed moment does not reflect the adjustment for the beam stability factor.

Supports	Bearing Length			Loads to Supports (lbs)			Accessories
	Total	Available	Required	Dead	Floor Live	Factored	
1 - Hanger on 11 7/8" PSL beam	5.50"	Hanger ¹	2.29"	1427	3597	5024	See note ¹
2 - Column Cap - steel	5.50"	5.50"	1.50"	645	1556	2201	Blocking

- Blocking Panels are assumed to carry no loads applied directly above them and the full load is applied to the member being designed.
- At hanger supports, the Total Bearing dimension is equal to the width of the material that is supporting the hanger
- ¹ See Connector grid below for additional information and/or requirements.

Lateral Bracing	Bracing Intervals	Comments
Top Edge (Lu)	9' 3" o/c	
Bottom Edge (Lu)	9' 3" o/c	

•Maximum allowable bracing intervals based on applied load.

Connector: Simpson Strong-Tie

Support	Model	Seat Length	Top Fasteners	Face Fasteners	Member Fasteners	Accessories
1 - Face Mount Hanger	HHUS410	3.00"	N/A	30-16d	10-16d	

- Refer to manufacturer notes and instructions for proper installation and use of all connectors.

Vertical Loads	Location (Side)	Tributary Width	Dead (0.90)	Floor Live (1.00)	Comments
0 - Self Weight (PLF)	5 1/2" to 9' 8"	N/A	13.0	--	
1 - Uniform (PSF)	0 to 9' 8" (Front)	1'	12.0	40.0	Floor Load
2 - Point (lb)	3' (Top)	N/A	1837	4766	Linked from: 2B-4, Support 1

• Side loads are assumed to not induce cross-grain tension.

Weyerhaeuser Notes

Weyerhaeuser warrants that the sizing of its products will be in accordance with Weyerhaeuser product design criteria and published design values. Weyerhaeuser expressly disclaims any other warranties related to the software. Use of this software is not intended to circumvent the need for a design professional as determined by the authority having jurisdiction. The designer of record, builder or framer is responsible to assure that this calculation is compatible with the overall project. Accessories (Rim Board, Blocking Panels and Squash Blocks) are not designed by this software. Products manufactured at Weyerhaeuser facilities are third-party certified to sustainable forestry standards. Weyerhaeuser Engineered Lumber Products have been evaluated by ICC-ES under evaluation reports ESR-1153 and ESR-1387 and/or tested in accordance with applicable ASTM standards. For current code evaluation reports, Weyerhaeuser product literature and installation details refer to www.woyherhaeuser.com/woodproducts/document-library.

The product application, input design loads, dimensions and support information have been provided by ForteWEB Software Operator

ForteWEB Software Operator	Job Notes
Harrison Kliegl L120 Engineering (425) 636-3313 hkliegl@l120engineering.com	



8/23/2024 3:55:53 AM UTC
 ForteWEB v3.8, Engine: V8.4.1.24, Data: V8.1.6.3
 File Name: Granbois Residence

Basement, 1C-1
1 piece(s) 6 x 8 DF No.1

Post Height: 10'



Design Results	Actual	Allowed	Result	LDF	Load: Combination
Slenderness	22	50	Passed (44%)	--	--
Compression (lbs)	14928	34053	Passed (44%)	1.60	1.0 D + 0.525 E + 0.75 L + 0.75 S
Base Bearing (lbs)	14928	25781	Passed (58%)	--	1.0 D + 0.525 E + 0.75 L + 0.75 S
Bending/Compression	0.51	1	Passed (51%)	1.60	1.0 D + 0.525 E + 0.75 L + 0.75 S

- Input axial load eccentricity for this design is 16.67% of applicable member side dimension.
- Applicable calculations are based on NDS.

Supports	Type	Material
Base	Plate	Douglas Fir-Larch

Member Type : Free Standing Post
 Building Code : IBC 2021
 Design Methodology : ASD

Max Unbraced Length	Comments
Full Member Length	No bracing assumed.

Drawing is Conceptual

Vertical Load	Dead (0.90)	Floor Live (1.00)	Seismic (1.60)	Comments
1 - Point (lb)	3450	7733	10815	

Weyerhaeuser Notes

Weyerhaeuser warrants that the sizing of its products will be in accordance with Weyerhaeuser product design criteria and published design values. Weyerhaeuser expressly disclaims any other warranties related to the software. Use of this software is not intended to circumvent the need for a design professional as determined by the authority having jurisdiction. The designer of record, builder or framer is responsible to assure that this calculation is compatible with the overall project. Accessories (Rim Board, Blocking Panels and Squash Blocks) are not designed by this software. Products manufactured at Weyerhaeuser facilities are third-party certified to sustainable forestry standards. Weyerhaeuser Engineered Lumber Products have been evaluated by ICC-ES under evaluation reports ESR-1153 and ESR-1387 and/or tested in accordance with applicable ASTM standards. For current code evaluation reports, Weyerhaeuser product literature and installation details refer to www.woyherhaeuser.com/woodproducts/document-library.

The product application, input design loads, dimensions and support information have been provided by ForteWEB Software Operator

ForteWEB Software Operator	Job Notes
Harrison Kliegl L120 Engineering (425) 636-3313 hkliegl@l120engineering.com	



Basement, 1C-2
1 piece(s) 6 x 8 DF No.1

Post Height: 10'



Design Results	Actual	Allowed	Result	LDF	Load: Combination
Slenderness	22	50	Passed (44%)	--	--
Compression (lbs)	13349	30428	Passed (44%)	1.15	1.0 D + 0.75 L + 0.75 S
Base Bearing (lbs)	13349	25781	Passed (52%)	--	1.0 D + 0.75 L + 0.75 S
Bending/Compression	0.57	1	Passed (57%)	1.15	1.0 D + 0.75 L + 0.75 S

- Input axial load eccentricity for this design is 16.67% of applicable member side dimension.
- Applicable calculations are based on NDS.

Supports	Type	Material
Base	Plate	Douglas Fir-Larch

Member Type : Free Standing Post
 Building Code : IBC 2021
 Design Methodology : ASD

Max Unbraced Length	Comments
Full Member Length	No bracing assumed.

Drawing is Conceptual

Vertical Load	Dead (0.90)	Floor Live (1.00)	Snow (1.15)	Comments
1 - Point (lb)	7807	3548	3841	Linked from: 2B-3, Support 2

Weyerhaeuser Notes

Weyerhaeuser warrants that the sizing of its products will be in accordance with Weyerhaeuser product design criteria and published design values. Weyerhaeuser expressly disclaims any other warranties related to the software. Use of this software is not intended to circumvent the need for a design professional as determined by the authority having jurisdiction. The designer of record, builder or framer is responsible to assure that this calculation is compatible with the overall project. Accessories (Rim Board, Blocking Panels and Squash Blocks) are not designed by this software. Products manufactured at Weyerhaeuser facilities are third-party certified to sustainable forestry standards. Weyerhaeuser Engineered Lumber Products have been evaluated by ICC-ES under evaluation reports ESR-1153 and ESR-1387 and/or tested in accordance with applicable ASTM standards. For current code evaluation reports, Weyerhaeuser product literature and installation details refer to www.eyerhaeuser.com/woodproducts/document-library.

The product application, input design loads, dimensions and support information have been provided by ForteWEB Software Operator

ForteWEB Software Operator	Job Notes
Harrison Kliegl L120 Engineering (425) 636-3313 hkliegl@l120engineering.com	



Garage, GH-1

1 piece(s) 5 1/2" x 15" 24F-V4 DF Glulam

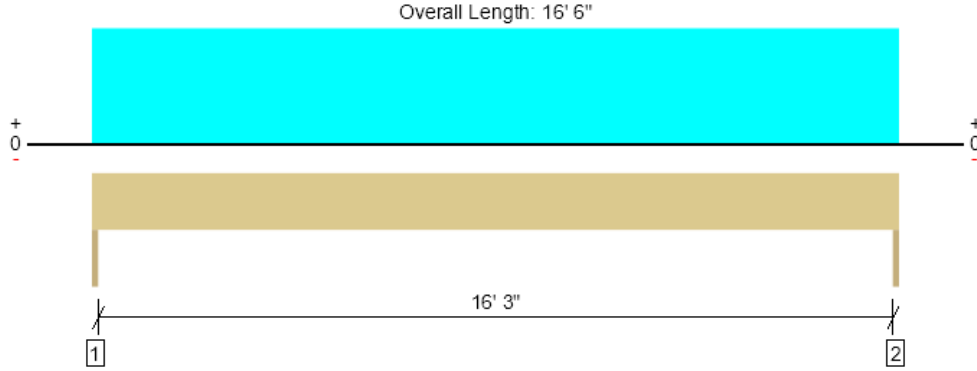

Drawing is Conceptual. All locations are measured from the outside face of left support (or left cantilever end). All dimensions are horizontal (typ.).

Design Results	Actual @ Location	Allowed	Result	LDF	Load: Combination (Pattern)
Member Reaction (lbs)	4569 @ 0	5363 (1.50")	Passed (85%)	--	1.0 D + 1.0 S (All Spans)
Shear (lbs)	3807 @ 1' 4 1/2"	16761	Passed (23%)	1.15	1.0 D + 1.0 S (All Spans)
Pos Moment (Ft-lbs)	18847 @ 8' 3"	45406	Passed (42%)	1.15	1.0 D + 1.0 S (All Spans)
Live Load Defl. (in)	0.165 @ 8' 3"	0.550	Passed (L/999+)	--	1.0 D + 1.0 S (All Spans)
Total Load Defl. (in)	0.332 @ 8' 3"	0.825	Passed (L/597)	--	1.0 D + 1.0 S (All Spans)

Member Length : 16' 6"
 System : Wall
 Member Type : Header
 Building Use : Residential
 Building Code : IBC 2021
 Design Methodology : ASD

- Deflection criteria: LL (L/360) and TL (L/240).
- A 4.3% decrease in the moment capacity has been added to account for lateral stability.
- Critical positive moment adjusted by a volume/size factor of 0.99 that was calculated using length L = 16' 6".
- The effects of positive or negative camber have not been accounted for when calculating deflection.
- The specified glulam is assumed to have its strong laminations at the bottom of the beam. Install with proper side up as indicated by the manufacturer.
- Applicable calculations are based on NDS.

Supports	Bearing Length			Loads to Supports (lbs)			Accessories
	Total	Available	Required	Dead	Snow	Factored	
1 - Trimmer - HF	1.50"	1.50"	1.50"	2300	2269	4569	None
2 - Trimmer - HF	1.50"	1.50"	1.50"	2300	2269	4569	None

Lateral Bracing	Bracing Intervals	Comments
Top Edge (Lu)	End Bearing Points	
Bottom Edge (Lu)	End Bearing Points	

Vertical Loads	Location	Tributary Width	Dead (0.90)	Snow (1.15)	Comments
0 - Self Weight (PLF)	0 to 16' 6"	N/A	20.0	--	
1 - Uniform (PSF)	0 to 16' 6"	11'	16.2	25.0	Roof Load
2 - Uniform (PLF)	0 to 16' 6"	N/A	80.0	-	2 ft brick load

Weyerhaeuser Notes

Weyerhaeuser warrants that the sizing of its products will be in accordance with Weyerhaeuser product design criteria and published design values. Weyerhaeuser expressly disclaims any other warranties related to the software. Use of this software is not intended to circumvent the need for a design professional as determined by the authority having jurisdiction. The designer of record, builder or framer is responsible to assure that this calculation is compatible with the overall project. Accessories (Rim Board, Blocking Panels and Squash Blocks) are not designed by this software. Products manufactured at Weyerhaeuser facilities are third-party certified to sustainable forestry standards. Weyerhaeuser Engineered Lumber Products have been evaluated by ICC-ES under evaluation reports ESR-1153 and ESR-1387 and/or tested in accordance with applicable ASTM standards. For current code evaluation reports, Weyerhaeuser product literature and installation details refer to www.weyerhaeuser.com/woodproducts/document-library.

The product application, input design loads, dimensions and support information have been provided by ForteWEB Software Operator

ForteWEB Software Operator	Job Notes
Harrison Kliegl L120 Engineering (425) 636-3313 hkliegl@l120engineering.com	



8/23/2024 3:55:53 AM UTC
 ForteWEB v3.8, Engine: V8.4.1.24, Data: V8.1.6.3
 File Name: Granbois Residence

Garage, GH-2

1 piece(s) 3 1/2" x 9" 24F-V4 DF Glulam

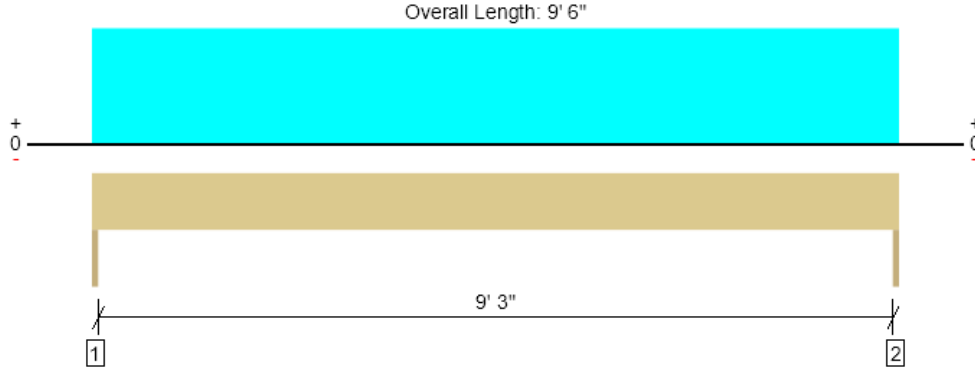

Drawing is Conceptual. All locations are measured from the outside face of left support (or left cantilever end). All dimensions are horizontal (typ.).

Design Results	Actual @ Location	Allowed	Result	LDF	Load: Combination (Pattern)
Member Reaction (lbs)	2572 @ 0	3413 (1.50")	Passed (75%)	--	1.0 D + 1.0 S (All Spans)
Shear (lbs)	2098 @ 10 1/2"	6400	Passed (33%)	1.15	1.0 D + 1.0 S (All Spans)
Pos Moment (Ft-lbs)	6108 @ 4' 9"	10504	Passed (58%)	1.15	1.0 D + 1.0 S (All Spans)
Live Load Defl. (in)	0.132 @ 4' 9"	0.317	Passed (L/866)	--	1.0 D + 1.0 S (All Spans)
Total Load Defl. (in)	0.259 @ 4' 9"	0.475	Passed (L/440)	--	1.0 D + 1.0 S (All Spans)

Member Length : 9' 6"
 System : Wall
 Member Type : Header
 Building Use : Residential
 Building Code : IBC 2021
 Design Methodology : ASD

- Deflection criteria: LL (L/360) and TL (L/240).
- A 3.3% decrease in the moment capacity has been added to account for lateral stability.
- Critical positive moment adjusted by a volume/size factor of 1.00 that was calculated using length L = 9' 6".
- The effects of positive or negative camber have not been accounted for when calculating deflection.
- The specified glulam is assumed to have its strong laminations at the bottom of the beam. Install with proper side up as indicated by the manufacturer.
- Applicable calculations are based on NDS.

Supports	Bearing Length			Loads to Supports (lbs)			Accessories
	Total	Available	Required	Dead	Snow	Factored	
1 - Trimmer - HF	1.50"	1.50"	1.50"	1265	1306	2572	None
2 - Trimmer - HF	1.50"	1.50"	1.50"	1265	1306	2572	None

Lateral Bracing	Bracing Intervals	Comments
Top Edge (Lu)	End Bearing Points	
Bottom Edge (Lu)	End Bearing Points	

Vertical Loads	Location	Tributary Width	Dead (0.90)	Snow (1.15)	Comments
0 - Self Weight (PLF)	0 to 9' 6"	N/A	7.7	--	
1 - Uniform (PSF)	0 to 9' 6"	11'	16.2	25.0	Roof Load
2 - Uniform (PLF)	0 to 9' 6"	N/A	80.0	-	2 ft brick load

Weyerhaeuser Notes

Weyerhaeuser warrants that the sizing of its products will be in accordance with Weyerhaeuser product design criteria and published design values. Weyerhaeuser expressly disclaims any other warranties related to the software. Use of this software is not intended to circumvent the need for a design professional as determined by the authority having jurisdiction. The designer of record, builder or framer is responsible to assure that this calculation is compatible with the overall project. Accessories (Rim Board, Blocking Panels and Squash Blocks) are not designed by this software. Products manufactured at Weyerhaeuser facilities are third-party certified to sustainable forestry standards. Weyerhaeuser Engineered Lumber Products have been evaluated by ICC-ES under evaluation reports ESR-1153 and ESR-1387 and/or tested in accordance with applicable ASTM standards. For current code evaluation reports, Weyerhaeuser product literature and installation details refer to www.weyerhaeuser.com/woodproducts/document-library.

The product application, input design loads, dimensions and support information have been provided by ForteWEB Software Operator

ForteWEB Software Operator	Job Notes
Harrison Kliegl L120 Engineering (425) 636-3313 hkliegl@l120engineering.com	



8/23/2024 3:55:53 AM UTC
 ForteWEB v3.8, Engine: V8.4.1.24, Data: V8.1.6.3
 File Name: Granbois Residence



LONGITUDE
ONE TWENTY°
ENGINEERING & DESIGN

Lateral Design

Lateral-force design element calculation references are shown on structural plans for ease of reference

Project Number: S230110-1	Plan Name: Granbois	Sheet Number: DC
Engineer: HK	Specifics: Design Criteria	Date: 8/22/2024

Gravity Criteria:

Code: IBC 2021

ROOF SYSTEM			
Live Load:			
Snow	25.0	psf	
Dead Load:			
Composite Roofing	2.0	psf	
19/32" Plywood Sheathing	2.5	psf	
Trusses at 24" o.c.	3.0	psf	
Insulation	1.8	psf	
(2) Layers 5/8" GWB	4.4	psf	
Misc/Mech	1.3	psf	
Total	15.0	psf	

FLOOR SYSTEM			
Live Load:			
Residential	40.0	psf	
Dead Load:			
Flooring	3.0	psf	
3/4" T & G Plywood	2.5	psf	
Floor Joists at 16" o.c.	2.5	psf	
Insulation	0.5	psf	
(1) Layers 5/8" GWB	2.2	psf	
Miscellaneous	1.3	psf	
Total	12.0	psf	

EXTERIOR WALL SYSTEM			
2x6 at 16" o.c.	1.7	psf	
Insulation	1.0	psf	
1/2" Plywood Sheathing	1.5	psf	
(2) layers 5/8" GWB	4.4	psf	
Misc	3.4	psf	
Total	12.0	psf	

EXTERIOR WALL W/THINSET BRICK			
2x6 at 16" o.c.	1.7		
Insulation	1.0	psf	
1/2" Plywood Sheathing	1.5	psf	
(2) layers 5/8" GWB	4.5	psf	
Brick Cladding	15.0	psf	
Total	22.0	psf	

INTERIOR WALL SYSTEM			
2x4 at 16" o.c.	1.1	psf	
Insulation	0.5	psf	
(2) Layers 5/8" GWB	4.4	psf	
Misc	2.0	psf	
Total	8.0	psf	

SEISMIC PARAMETERS:

Code Reference: ASCE 7-16

R = **6.5** Bearing Wall System, Wood Structural Panel Walls

Mapped Spectral Acceleration, S_s = **1.64**

Mapped Spectral Acceleration, S₁ = **0.62**

Soil Site Class = **D**

WIND PARAMETERS:

Code Reference: ASCE 7-16

Basic Wind Speed (3 second Gust) = **100** mph

Exposure : **B**

K_{zt} = **1.90**

SOIL PARAMETERS:

Soil Bearing Pressure = **3,500** psf competent native soil or structural fill
1/3 increase for short-term wind or seismic loading is acceptable

Frost Depth = **18** in

Lateral Wall Pressures:

Unrestrained Active Pressure = **35** pcf Cantilevered walls

Restrained Active Pressure = **50** pcf Plate Wall Design/Tank Walls

Passive Pressure = **300** pcf

Soil Friction Coeff. = **0.5**

Project Number: S230110-1	Plan: Granbois	Sheet Number: L1
Engineer: HK	Specifics: WIND FORCES	Date: 8/22/2024

IBC 2021 Section 1609 → ASCE 7-16 Section 28.5 - Simplified Procedure → Main Wind-Force Resisting System

LOAD CRITERIA:

Basic Wind Speed, $V_s = 100$ mph (ASCE 7-16, Section 26.5)
 Exposure = **B** (ASCE 7-16, Section 26.7)

BUILDING GEOMETRY:

Roof Slope = **7.00** :12 = 30.26 degrees
 Loads From Front/Back - Width (ft) = **73.00** ft Roof: **Hip**
 Loads From Side - Width (ft) = **45.50** ft Roof: **Hip**
 Average Eave Height = **21.00** ft
 Mean Roof Ht. , $h = 29.00$ ft (ASCE 7-16, Figure 27.5-2)
 Edge Strip Width, $a = 4.55$ ft (ASCE 7-16, Figure 28.5-1)
 End Zone Width, $2a = 9.10$ ft (ASCE 7-16, Figure 28.5-1)

DESIGN:

Topographic Factor , $K_{zt} = 1.90$ (ASCE 7-16, Section 26.8)
 Adjustment Factor, $\lambda = 1.00$ (ASCE 7-16, Figure 28.5-1)

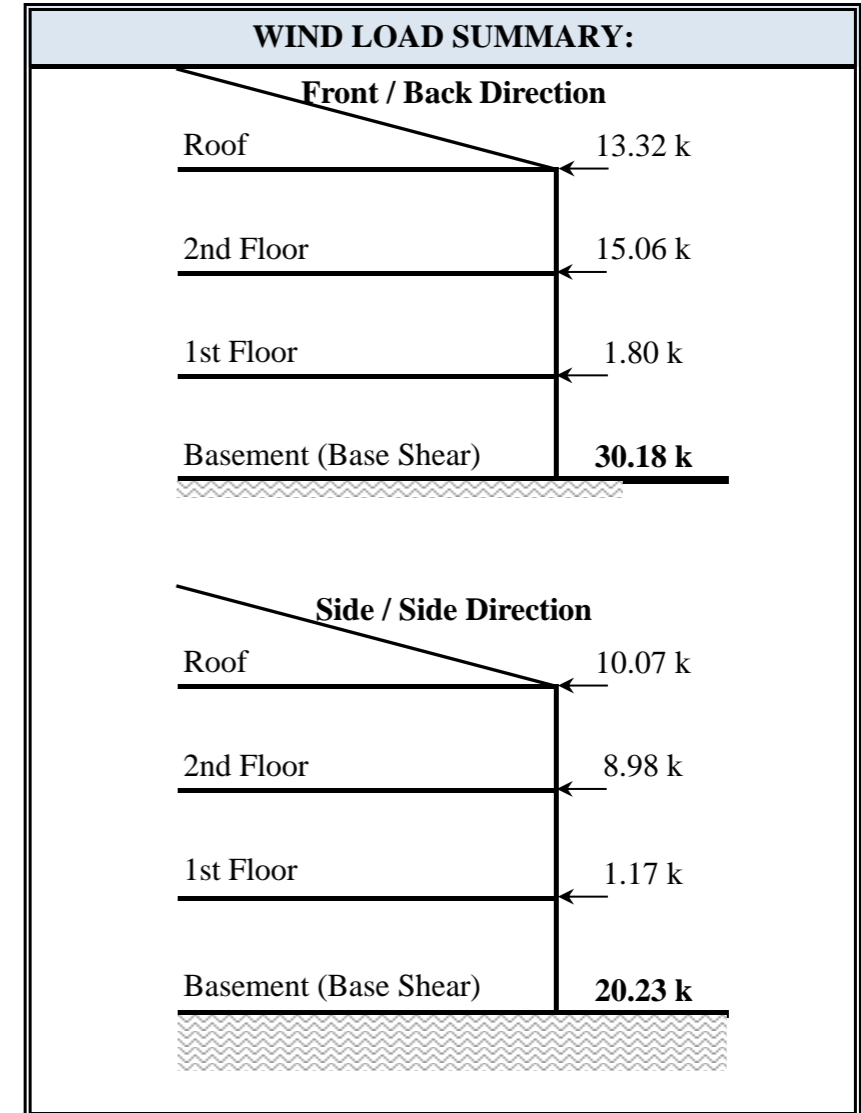

SIMPLIFIED DESIGN WIND PRESSURE, P_{S30} (psf)												
(Exposure B at $h = 30$ ft.)												
Basic Wind Speed, V_s (mph)	Roof Angle (Degrees)	Load Case	ZONES*									
			Horizontal Pressure				Vertical Pressure				Overhang	
			A	B	C	D	E	F	G	H	E_{OH}	G_{OH}
100	30.26	A	17.80	12.20	14.20	9.80	1.40	-10.80	0.50	-9.30	-6.30	-7.20

* Values Interpolated from Figure 28.5-1 ASCE 7 - 16

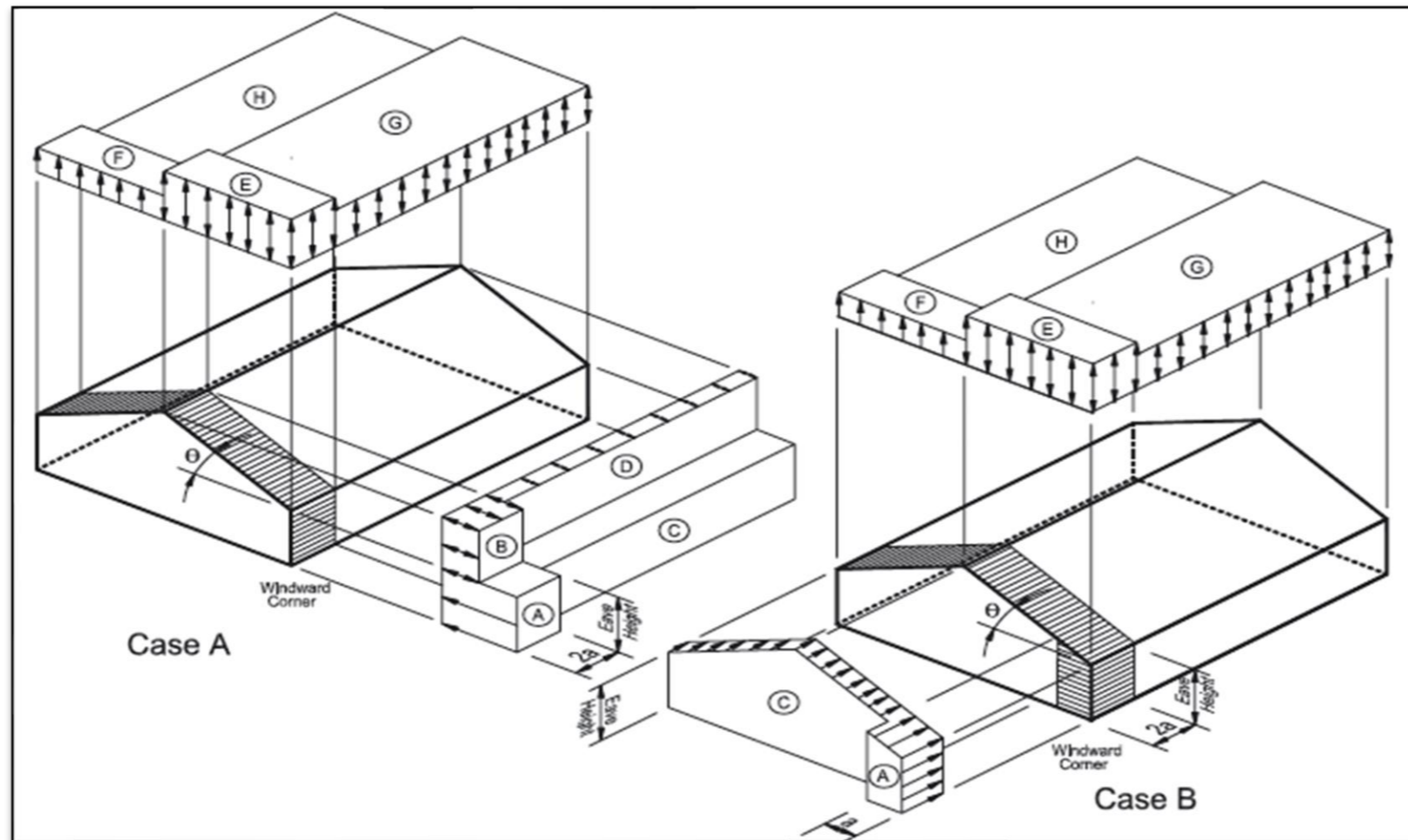

Project Number: S230110-1	Plan: Granbois	Sheet Number: L1
Engineer: HK	Specifics: WIND FORCES	Date: 8/22/2024

IBC 2021 Section 1609 → ASCE 7-16 Section 28.5 - Simplified Procedure → Main Wind-Force Resisting System

HORIZONTAL LOADS (psf)				MIN. LOADS (psf)	
$p_s = \lambda * K_z t * P_s 30$				Per ASCE 7-16, 28.6.3	
End zone		Interior zone		Roof	Wall
A (Wall)	B (Roof)	C (Wall)	D (Roof)		
33.82	23.18	26.98	18.62	8.0	16.0

Full Impact at Basement? **NO** (No = 1/4 Impact)

ASD WIND FORCES: FRONT / BACK LOADING DIRECTION										
Location	Width (ft)	Height (ft)	Plane	End Zone		Interior zone		Force 0.6 ω*W (kips)	Min Force 0.6 ω*W (kips)	
				Length (ft)	Pressure (W) (psf)	Length (ft)	Pressure (W) (psf)			
ROOF	"Height" of Roof to Plate (see note)	51.0	8.00	(roof)	9.1	23.18	41.9	18.62	6.18	2.55
	Plate to Mid 2nd LVL	73.0	4.50	(wall)	9.1	33.82	63.9	26.98	7.13	4.10
									Σ =	13.32
2nd FLOOR	Mid 2nd LVL to Floor	73.0	4.50	(wall)	9.1	33.82	63.9	26.98	7.13	4.10
	"Height" Low-Roof to Plate (see note)	0.0	0.00	(roof)	9.1	23.18	-9.1	18.62	0.00	0.00
	Floor to Mid 1st LVL	73.0	5.00	(wall)	9.1	33.82	63.9	26.98	7.92	4.56
								Σ =	15.06	8.65
1st FLOOR	Mid 1st LVL to Floor	64.0	5.00	(wall)	9.1	33.82	54.9	26.98	6.98	3.99
	"Height" Low-Roof to Plate (see note)	0.0	0.00	(roof)	9.1	23.18	-9.1	18.62	0.00	0.00
	Floor to Mid Basement LVL	0.0	5.00	(wall)	9.1	33.82	-9.1	26.98	0.24	0.00
								Σ =	1.80	1.00
								Total Wind Base Shear (kips)	30.18	16.30

Full Impact at Basement? **NO** (No = 1/4 Impact)

ASD WIND FORCES: SIDE / SIDE LOADING DIRECTION										
Location	Width (ft)	Height (ft)	Plane	End Zone		Interior zone		Force 0.6 ω*W (kips)	Min Force 0.6 ω*W (kips)	
				Length (ft)	Pressure (W) (psf)	Length (ft)	Pressure (W) (psf)			
ROOF	"Height" of Roof to Plate (see note)	45.5	8.00	(roof)	9.1	23.18	36.4	18.62	5.55	2.27
	Plate to Mid 2nd LVL	45.5	4.50	(wall)	9.1	33.82	36.4	26.98	4.53	2.56
									Σ =	10.07
2nd FLOOR	Mid 2nd LVL to Floor	45.5	4.50	(wall)	9.1	33.82	36.4	26.98	4.53	2.56
	"Height" Low-Roof to Plate (see note)	0.0	0.00	(roof)	9.1	23.18	-9.1	18.62	0.00	0.00
	Floor to Mid 1st LVL	40.0	5.00	(wall)	9.1	33.82	30.9	26.98	4.45	2.50
								Σ =	8.98	5.05
1st FLOOR	Mid 1st LVL to Floor	40.0	5.00	(wall)	9.1	33.82	30.9	26.98	4.45	2.50
	"Height" Low-Roof to Plate (see note)	0.0	0.00	(roof)	9.1	23.18	-9.1	18.62	0.00	0.00
	Floor to Mid Basement LVL	0.0	5.00	(wall)	9.1	33.82	-9.1	26.98	0.24	0.00
								Σ =	1.17	0.62
								Total Wind Base Shear (kips)	20.23	10.50

Project Number: S230110-1	Plan Name: Granbois	Sheet Number: L2
Engineer: HK	Specifics: SEISMIC WEIGHTS	Date: 8/22/2024

Unit Weights (psf)

Roof:	15	psf
Floor:	12	psf
Exterior Wall:	12	psf
Exterior Wall/Brick	22	psf
Interior Wall:	8	psf

Seismic Weights include: (REF §12.7)

25% of storage Live loads
 Actual partition weight or 10 psf min if applicable
 Operating weight of permanent equipment
 20% of uniform design snow loads for areas where Pf > 30 psf

LEVEL	ITEM	AREA / LENGTH	HEIGHT (ft)	UNIT WEIGHT (psf)		Item Total Weight. (lbs)	Level Sub-Total (kips)	Average Pressure (psf)
ROOF:								
	Roof	2,630	1.12	15	=	44,282		
	Ext. Wall Below	140	4.00	12	=	6,720		
	Ext. Wall w/Brick Below	145	4.00	22	=	12,760		
	Interior Wall Below	170	4.00	8	=	5,440		
							69	26
2nd FLOOR:								
	Floor	2,285	1.00	12	=	27,420		
	Low Roof	0	1.12	15	=	0		
	Ext. Wall Above	140	4.00	12	=	6,720		
	Ext. Wall w/Brick Above	145	4.00	22	=	12,760		
	Interior Wall Above	170	4.00	8	=	5,440		
	Ext. Wall Below	75	4.50	12	=	4,050		
	Ext. Wall w/Brick Below	145	4.50	22	=	14,355		
	Interior Wall Below	110	4.50	8	=	3,960		
							75	33
1st FLOOR:								
	Floor	2,210	1.00	12	=	26,520		
	Low Roof	0	1.12	15	=	0		
	Ext. Wall Above	75	4.50	12	=	4,050		
	Interior Wall Above	145	4.50	22	=	14,355		
	Interior Wall Above	110	4.50	8	=	3,960		
	Ext. Wall Below	75	4.50	12	=	4,050		
	Ext. Wall w/Brick Below	145	4.50	22	=	14,355		
	Interior Wall Below	100	0.00	8	=	0		
							67	30
BASEMENT:								
	Ext. Wall Above	75	4.50	12	=	4,050		
	Interior Wall Above	100	0.00	22	=	0		
							4	

STRUCTURE WEIGHT FOR SEISMIC BASE SHEAR: 211 kips

TOTAL WEIGHT OF STRUCTURE: 215 kips
 (Includes Basement Dead Load)

Project Number: S230110-1	Plan Name: Granbois	Sheet Number: L3
Engineer: HK	Specifics: SEISMIC FORCES	Date: 8/22/2024

Equivalent Lateral Force Analysis per IBC 2021 1613.1 → ASCE 7-16 Table 12.6-1 → Sec 12.8

Data generated by: [Seismic Design Values for Buildings](#)

"Java Ground Motion Parameter Calculation"

$S_1 = 0.62$ Maps
 $S_{DS} = 1.2$ (ASCE 7 EQ 11.4.-3)
 $S_{D1} = 0.85$ (ASCE 7 EQ 11.4.-4)
 Seismic Importance Factor = 1.00 (ASCE 7 Table 11.5-1)
 Seismic Design Category = D (ASCE 7 Table 11.6-1 & 11.6.2)
 Response Modification Factor, $R = 6.5$ (ASCE 7 Table 12.2-1)
 Seismic Force-Resisting System Description = [A.13 - light framed walls](#)

Building Height, $h_n = 30.0$ ft
 Building Period Coefficient, $C_T = 0.020$ (ASCE 7 Table 12.8.-2)
 Approx. Fundamental Period, $T_a = 0.256$ ($C_T \cdot (h_n^{0.75})$) (ASCE 7 EQ 12.8.-7)
 Approx. Fundamental Period, $T_L = 6.0$ sec (ASCE 7 11.4.6)

Seismic Response Coefficient

$C_s = S_{DS}/(R/I)$ $C_s = 0.185$ (ASCE 7 EQ 12.8.-2)

Seismic Response Coefficient, Maximum

$C_{s,MAX} = S_{D1}/(T \cdot R/I)$ $C_{s,MAX} = 0.510$ $T \leq T_L$ (ASCE 7 EQ 12.8.-3)

$C_{s,MAX} = S_{D1} T_L/(T^2 \cdot R/I)$ $C_{s,MAX} = NA$ $T > T_L$ (ASCE 7 EQ 12.8.-4)

Seismic Response Coefficient, Minimum

$C_{s,MIN} = 0.01$ $C_{s,MIN} = 0.010$ (ASCE 7 EQ 12.8.-5)

$C_{s,MIN} = 0.5 S_1 / (R/I)$ $C_{s,MIN} = 0.048$ if $S_1 > 0.6$ (ASCE 7 EQ 12.8.-6)

$C_s = 0.185$
 Dead Load $W = 211$ kips
 $V = C_s W = 39.0$ kips (ASCE 7 EQ 12.8.-1)
 $Q_E = V = 39.0$ kips (ASCE 7 EQ 12.4-3)
 $\rho = 1.0$ (ASCE 7 12.3.4.2)
 $E_H = \rho Q_E = 39.0$ kips (ASCE 7 EQ 12.4-3)
 $E_v = .2 S_{DS} D = 0.24$ x D kips

Factor for Alternate Basic Load combinations - 2021 IBC

$E_H/1.4 = 27.9$ kips IBC 2021 1605 (Eq 16-6)
 $k = 1$ (ASCE 7 12.8.3)

VERTICAL DISTRIBUTION (Per ASCE 7 - 12.8.3)								
Floor	Area (ft ²)	Story Height H (ft)	Total Height h _x (ft)	Story Weight w _x (kips)	w _x h _x ^k (k-ft)	Vert Dist Factor C _{vx}	Story Force F _x (kips)	Factored Story Force (ASD) F _x ρ/1.4 = E _H /1.4 (kips)
Roof	2,630	7.00	27.00	69	1,868	0.46	18.1	12.9
2nd	2,285	10.00	20.00	75	1,494	0.37	14.4	10.3
1st	2,210	10.00	10.00	67	673	0.17	6.5	4.6
Sum =					4,035	1.000	39.0	27.9

Project Number: S230110-1	Plan Name: Granbois	Sheet Number: L4
Engineer: HK	Specifics: DESIGN LOADS	Date: 8/22/2024

FRONT / BACK DIRECTION

Wind Force <i>0.6 ω * W_{F/B} (kips)</i>		Seismic Force <i>E/1.4 (kips)</i>	
Per Level	Sum	Per Level	Sum
13.32		12.89	
	13.32	10.31	12.89
15.06		4.64	23.21
	28.37		27.85
1.80			
	30.18		

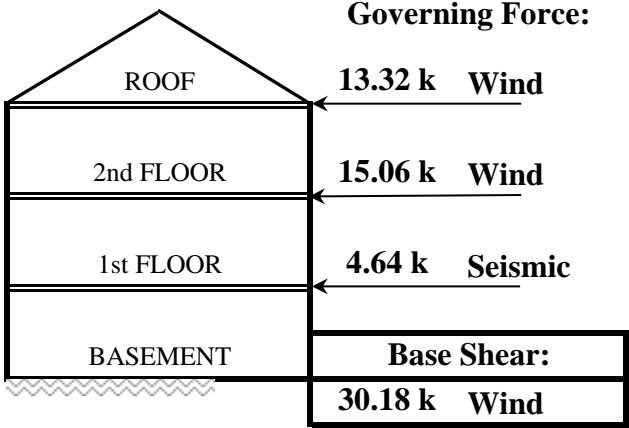

SIDE / SIDE DIRECTION

Wind Force <i>0.6 ω * W_S (kips)</i>		Seismic Force <i>E/1.4 (kips)</i>	
Per Level	Sum	Per Level	Sum
10.07		12.89	
	10.07	10.31	12.89
8.98		4.64	23.21
	19.05		27.85
1.17			
	20.23		

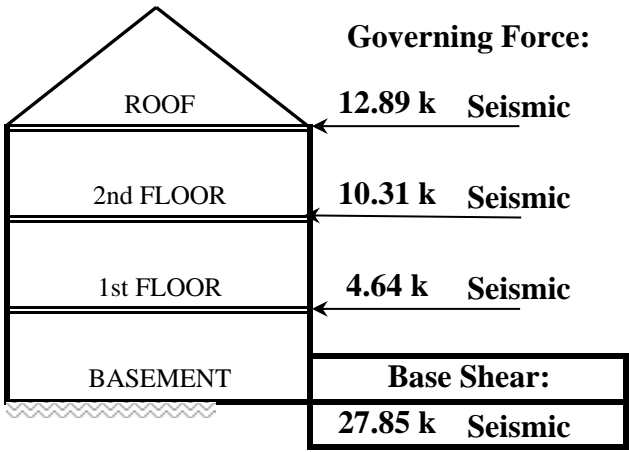

Project Number: S230110-1	Plan Name: Granbois	Sheet Number: L5
Engineer: HK	Specifics: Shear walls (front/back)	Date: 8/22/2024

Notes:
 * All walls designed with Force-Transfer should meet a minimum height to width ratio of 2:1 at Pier (SDPWS 2021, Table 4.3.3)
 * Maximum allowed height to width ratio 3.5:1 for walls w/o openings (increased shear design values per SDPWS 2021, Table 4.3.3)
 * Shear panel height is height to underside or roof or floor framing.

RED = Update Formula as required - Important
BLUE = Review and update as required - Typical Input

2nd Story Walls (Front - Back Direction)

Stud Species **HF**
 Story shear(kips) = **13.32**
 Story height (ft) = **10.00**
 Shear Panel height (ft) = **9.00**
 Total Diaphragm Area (sq ft) = **2630.00**
 100% story shear **YES**
 Governing Force (F/B Direction) = **Wind**
 Dead load factor (F/B Direction) = **0.67**
 Shear panel capacity (Wind or Seismic) = **Wind**
 load balance check = **OK**

IBC 2021 Sec. 1605.2

2nd Story Walls (Front - Back Direction)
Hold downs and window straps

Story	Wall Mark	Wall L(ft)	Opening Width (ft)	Opening Height (ft)	Opening (max) to Edge (ft)	Plate to Opening (ft)	Effective Length (ft)	Trib. Area (sq ft)	Percent Sharing (%)	Effective Trib. Area	Story V(kips)	Sum V(kips)	Panel Shear (plf)	Height/Width Reduction (%) R = 2*L/H	Design Panel Shear (plf)	Wall Type	NOVACORE (R-S) WALL RESTRICTION	Floor DL Trib(ft)	Story DL(klf)	Walls/DL Stacks?	Sum DL(klf)	OTM (k-ft)	RM (k-ft)	Resultant HD(kips)	HD TYPE	HD/Strap to DF or HF?	HD location Edge/Interior?	Resultant HD	Force at Window (Kips)	Window Strap
2	1.1	13.50	6.00	5.00	3.25	1.50	7.50	490.00	0.42	204.17	1.03	1.03	138	1.00	138	SW6	SW6	8.00	0.54	0.54	10.3	33.2	-1.75	fr-flr	HF	Edge	No HD	1.19	CS16	
2	1.2	13.50	3.00	5.00	4.00	1.50	10.50	490.00	0.58	285.83	1.45	1.45	138	1.00	138	SW6	SW6	8.00	0.54	0.54	14.5	33.2	-1.44	fr-flr	HF	Edge	No HD	1.47	CS16	
2	2.0	18.00					18.00	620.00	1.00	620.00	3.14	3.14	174	1.00	174	SW6	SW6	8.00	0.23	0.23	31.4	24.7	0.38	fr-flr	HF	Edge	No HD	0.00	No strap	
2	3.1	17.50					17.50	690.00	0.60	416.38	2.11	2.11	120	1.00	120	SW6	SW6	2.00	0.14	0.14	21.1	14.2	0.41	fr-flr	HF	Edge	No HD	0.00	No strap	
2	3.2	11.50					11.50	690.00	0.40	273.62	1.39	1.39	120	1.00	120	SW6	SW6	2.00	0.14	0.14	13.9	6.1	0.70	fr-flr	HF	Edge	MST37	0.00	No strap	
2	4.1	15.50					15.50	600.00	0.57	344.44	1.74	1.74	113	1.00	113	SW6	SW6	7.00	0.21	0.21	17.4	17.1	0.02	fr-flr	HF	Edge	No HD	0.00	No strap	
2	4.2	11.50					11.50	600.00	0.43	255.56	1.29	1.29	113	1.00	113	SW6	SW6	2.00	0.45	0.45	12.9	20.1	-0.65	fr-flr	HF	Edge	No HD	0.00	No strap	
2	5.0	15.75					15.75	230.00	1.00	230.00	1.16	1.16	74	1.00	74	SW6	SW6	7.00	0.21	0.21	11.6	17.7	-0.40	fr-flr	HF	Edge	No HD	0.00	No strap	
S =		116.75	Total OSB wall length = (feet)		36.00	S =		2630.00	13.32	13.32	OK	Total OSB Capacity (kips)		13.32																

1st Story Walls (Front - Back Direction)

Story shear(kips) = **15.06**
 Story height (ft) = **10.08**
 Shear Panel height (ft) = **9.08**
 Total Diaphragm Area (sq ft) = **2285.00**
 Shear panel capacity (Wind or Seismic) = **Wind**
 Accumulated Shear = **28.37**
 load balance check = **OK**

1st Story Walls (Front - Back Direction)
Hold downs and window straps

Story	Wall Mark	Wall L(ft)	Opening Width (ft)	Opening Height (ft)	Opening (max) to Edge (ft)	Plate to Opening (ft)	Effective Length (ft)	Trib. Area (sq ft)	Percent Sharing (%)	Effective Trib. Area	Story V(kips)	Sum V(kips)	Panel Shear (plf)	Height/Width Reduction (%) R = 2*L/H	Design Panel Shear (plf)	Wall Type	NOVACORE (R-S) WALL RESTRICTION	Floor DL Trib(ft)	Story DL(klf)	Walls/DL Stacks?	Sum DL(klf)	OTM (k-ft)	RM (k-ft)	Resultant HD(kips)	HD TYPE	HD/Strap to DF or HF?	HD location Edge/Interior?	Resultant HD	Force at Window (Kips)	Window Strap
1	1.1	13.50	6.00	5.00	3.25	1.50	7.50	440.00	0.42	183.33	1.21	2.24	299	1.00	299	SW4	2W4/6	3.00	0.47	YES	1.01	22.6	28.6	-0.46	fr-conc	HF	Edge	HDU2	2.59	CMSTC16
1	1.2	13.50	3.00	5.00	4.00	1.50	10.50	440.00	0.58	256.67	1.69	3.14	299	1.00	299	SW4	2W4/6	3.00	0.47	YES	1.01	31.6	28.6	0.24	fr-conc	HF	Edge	HDU2	3.19	CMSTC16
1	2.0	18.00					18.00	530.00	1.00	530.00	3.49	6.63	368	1.00	368	SW3	N/A	8.00	0.23	YES	0.77	66.8	24.7	2.41	fr-flr	HF	Edge	MST48	0.00	No strap
1	3.1	16.50					16.50	515.00	0.59	306.22	2.02	4.13	250	1.00	250	SW4	N/A	2.00	0.14	YES	0.37	41.6	12.6	1.81	fr-flr	HF	Edge	MST37	0.00	No strap
1	3.2	11.25					11.25	515.00	0.41	208.78	1.38	2.76	245	1.00	245	SW4	N/A	2.00	0.14	YES	0.28	27.8	5.9	2.04	fr-beam	HF	Edge	HDU5	0.00	No strap
1	4.1	3.50					3.50	690.00	0.30	210.00	1.38	2.31	659	1.00	659	2W4	2W3/3	2.00	0.45	YES	0.59	23.3	1.9	7.14	fr-conc	DF-L	Edge	HDU11	0.00	No strap
1	4.2	8.00					8.00	690.00	0.70	480.00	3.16	5.28	659	1.00	659	2W4	2W3/3	3.00	0.47	YES	0.68	53.2	10.0	5.75	fr-conc	DF-L	Edge	HDU8	0.00	No strap
1	5.0	7.67					7.67	220.00	0.67	146.73	0.97	2.13	278	1.00	278	SW4	N/A	4.00	0.17	NO	0.17	21.5	3.3	2.53	fr-conc	HF	Edge	HDU5	0.00	No strap
S =		91.92	Total OSB wall length = (feet)		52.50	S =		2321.73	9.78	28.61	OK	Total OSB Capacity (kips)		15.06																

Basement Walls (Front - Back Direction)

Story shear(kips) = **4.64**
 Story height (ft) = **10.08**
 Shear Panel height (ft) = **9.08**
 Total Diaphragm Area (sq ft) = **2210.00**
 Accumulated Shear = **15.98** **The rest of the story shear from above has been transferred into foundation**
 load balance check = **Warning-Wall loads do not match story shear**

Basement Walls (Front - Back Direction)
Hold downs and window straps

Story	Wall Mark	Wall L(ft)	Opening Width (ft)	Opening Height (ft)	Opening (max) to Edge (ft)	Plate to Opening (ft)	Effective Length (ft)	Trib. Area (sq ft)	Percent Sharing (%)	Effective Trib. Area	Story V(kips)	Sum V(kips)	Panel Shear (plf)	Height/Width Reduction (%) R = 2*L/H	Design Panel Shear (plf)	Wall Type	Wall Mark	Story DL(klf)	Sum DL(klf)	Walls/DL Stacks?	Sum DL(klf)	OTM (k-ft)	RM (k-ft)	Resultant HD(kips)	HD TYPE	Resultant HD	Force at Window (Kips)	Window Strap		
B	2.0	18.00					18.00	590.00	1.00	590.00	1.24	7.87	437	1.00	437	SW3	2.0	8.00	0.23	YES	1.00	79.3	24.7	3.12	fr-conc	HF	Edge	STHD14	0.00	No strap
B	3.0	14.67					14.67	580.00	1.00	580.00	1.22	8.11	553	1.00	553	SW2	3.0	9.00	0.24	YES	0.61	81.7	17.5	4.53	fr-conc	HF	Edge	HDU8	0.00	No strap
B	CONCRETE FOUNDATION						CONCRETE FOUNDATION								CONCRETE FOUNDATION										CONCRETE FOUNDATION					
B																														
B																														
S =		32.67					S =		1170.00	2.46	15.98	Warning-Wall loads do not match story shear																		

Project Number: S230110-1	Plan Name: Granbois	Sheet Number: L6
Engineer: HK	Specifics: Shear walls (side/side)	Date: 8/22/2024

Notes:
 * All walls designed with Force-Transfer should meet a minimum height to width ratio of 2:1 at Pier (SDPWS 2021, Table 4.3.3)
 * Maximum allowed height to width ratio 3.5:1 for walls w/o openings (increased shear design values per SDPWS 2021, Table 4.3.3)
 * Shear panel height is height to underside of roof or floor framing.

RED = Update Formula as required - Important
BLUE = Review and update as required - Typical Input

2nd Story Walls (Side / Side Direction)

Stud Species: HF

Story shear(kips) = **12.89**
 Story height (ft) = **9.08**
 Shear Panel height (ft) = **8.08**
Total Diaphragm Area (sq ft) = 2630.00

Governing Force (E/B Direction) = **Seismic**
 Dead load factor (E/B Direction) = **0.90**
 Shear panel capacity (Wind or Seismic) = **Seismic**
 load balance check = **OK**

IBC 2021 Equation 16-6

Story	Wall Mark	Wall L(ft)	Opening Width (ft)	Opening Height (ft)	Opening (max) to Edge (ft)	Plate to Opening (ft)	Effective Length (ft)	Trib. Area (sq ft)	Percent Sharing (%)	Effective Trib. Area	Story V(kips)	Sum V(kips)	Panel Shear (plf)	Height/Width Reduction (%) R = 2*L/H	Design Panel Shear (plf)	Wall Type	LP NOVACORE (R-S) WALL DESIGNATION	Floor DL Trib(ft)	Story DL(klf)	Walls/DL Stacks?	Sum DL(klf)	OTM (k-ft)	RM (k-ft)	Resultant HD(kips)	HD TYPE	HD/Strap to DF or HF?	HD location Edge/Interior?	Resultant HD	Force at Window (Kips)	Window Strap
2	A1	4.50					4.50	550.00	0.26	145.59	0.71	0.71	159	1.00	159	SW6	SW6	2.00	0.41		0.41	6.5	3.7	0.69	flr-flr	HF	Edge	MST137	0.00	No strap
2	A2	4.50					4.50	550.00	0.26	145.59	0.71	0.71	159	1.00	159	SW6	SW6	2.00	0.41		0.41	6.5	3.7	0.69	flr-flr	HF	Edge	MST137	0.00	No strap
2	A3	8.00					8.00	550.00	0.47	258.82	1.27	1.27	159	1.00	159	SW6	SW6	2.00	0.13		0.13	11.5	3.7	1.05	flr-beam	HF	Edge	MSTC48B3	0.00	No strap
2	B1	10.00					10.00	1330.00	0.33	443.33	2.17	2.17	217	1.00	217	SW6	SW6	2.00	0.13		0.13	19.7	5.7	1.48	flr-flr	HF	Edge	MST137	0.00	No strap
2	B2	20.00					20.00	1330.00	0.67	886.67	4.35	4.35	217	1.00	217	SW6	SW6	7.00	0.20		0.20	39.5	36.4	0.16	flr-beam	HF	Edge	No HD	0.00	No strap
2	C1	16.00	3.00	5.00	4.00	0.50	13.00	750.00	0.59	443.18	2.17	2.17	167	1.00	167	SW6	SW6	2.00	0.41		0.41	19.7	47.2	-1.77	flr-beam	HF	Edge	No HD	4.01	CMSTC16
2	C2	9.00					9.00	750.00	0.41	306.82	1.50	1.50	167	1.00	167	SW6	SW6	7.00	0.48		0.48	13.7	17.7	-0.47	flr-flr	HF	Edge	No HD	0.00	No strap

S = 72.00 Total OSB wall length = 27.00 S = 2630.00 12.89 **12.89** OK Total OSB Capacity = 12.89

1st Story Walls (Side / Side Direction)

Shear panel capacity (Wind or Seismic) = **Seismic**

1st Story Walls (Side / Side Direction)
 Hold downs and window straps

Story shear(kips) = **10.31**
 Story height (ft) = **10.08**
 Shear Panel height (ft) = **9.08**
Total Diaphragm Area (sq ft) = 2285.00

Accumulated Shear = **23.21**
 load balance check = **OK**

Story	Wall Mark	Wall L(ft)	Opening Width (ft)	Opening Height (ft)	Opening (max) to Edge (ft)	Plate to Opening (ft)	Effective Length (ft)	Trib. Area (sq ft)	Percent Sharing (%)	Effective Trib. Area	Story V(kips)	Sum V(kips)	Panel Shear (plf)	Height/Width Reduction (%) R = 2*L/H	Design Panel Shear (plf)	Wall Type	LP NOVACORE (R-S) WALL DESIGNATION	Floor DL Trib(ft)	Story DL(klf)	Walls/DL Stacks?	Sum DL(klf)	OTM (k-ft)	RM (k-ft)	Resultant HD(kips)	HD TYPE	HD/Strap to DF or HF?	HD location Edge/Interior?	Resultant HD	Force at Window (Kips)	Window Strap
1	A1	16.50	8.00	5.00	3.50	1.00	8.50	1130.00	0.33	372.90	1.68	3.11	366	1.00	366	SW3	2W4/6	5.00	0.54	YES	0.95	31.4	116.9	-5.35	flr-conc	HF	Edge	No HD	4.48	CMSTC16
1	A2	5.00					5.00	1130.00	0.33	372.90	1.68	2.32	463	1.00	463	SW2	2W3/3	5.00	0.54	YES	0.95	23.4	10.7	2.80	flr-conc	DF-L	Edge	STHD14	0.00	No strap
1	A3	4.83					4.83	1130.00	0.33	372.90	1.68	2.32	480	1.00	480	SW2	2W3/3	10.00	0.24	NO	0.24	23.4	2.6	4.80	flr-conc	DF-L	Edge	H DU5	0.00	No strap
1	B1	9.50					9.50	600.00	0.41	247.83	1.12	3.81	401	1.00	401	SW3	N/A	7.00	0.21	YES	0.33	38.4	13.6	2.76	flr-beam	DF-L	Edge	MSTC48B3	0.00	No strap
1	B2	8.00					8.00	600.00	0.35	208.70	0.94	3.21	401	1.00	401	SW3	N/A	7.00	0.21	NO	0.21	32.4	6.0	3.52	flr-beam	DF-L	Edge	H DU4	0.00	No strap
1	B3	5.50					5.50	600.00	0.24	143.48	0.65	2.21	401	1.00	401	SW3	N/A	3.00	0.16	NO	0.16	22.2	2.2	4.01	flr-beam	DF-L	Edge	H DU4	0.00	No strap
1	C1	3.50					3.50	570.00	0.18	102.31	0.46	1.55	442	0.77	574	SW2	2W3/3	7.00	0.57	NO	0.57	15.6	3.1	4.16	flr-conc	DF-L	Edge	H DU4	0.00	No strap
1	C2	4.00					4.00	570.00	0.21	116.92	0.53	1.61	404	0.88	458	SW2	2W3/3	7.00	0.57	NO	0.57	16.3	4.1	3.48	flr-conc	DF-L	Edge	STHD14	0.00	No strap
1	C3	18.00	6.00	5.75	4.00	1.00	12.00	570.00	0.62	350.77	1.58	3.09	257	1.00	257	SW4	2W4/6	3.00	0.16	NO	0.16	31.1	23.3	0.45	flr-conc	HF	Edge	H DU4	3.99	CMSTC16

S = 74.83 Total OSB wall length = 41.33 S = 2288.70 10.33 **23.22** OK Total OSB Capacity = 10.31

Basement Walls (Side / Side Direction)

Shear panel capacity (Wind or Seismic) = **Seismic**

Basement Walls (Side / Side Direction)
 Hold downs and window straps

Story shear(kips) = **4.64**
 Story height (ft) = **10.08**
 Shear Panel height (ft) = **9.08**
Total Diaphragm Area (sq ft) = 2210.00

Accumulated Shear = **11.36** **The rest of the story shear from above has been transferred into foundation**
 load balance check = **Warning-Wall loads do not match story shear**

Story	Wall Mark	Wall L(ft)	Opening Width (ft)	Opening Height (ft)	Opening (max) to Edge (ft)	Plate to Opening (ft)	Effective Length (ft)	Trib. Area (sq ft)	Percent Sharing (%)	Effective Trib. Area	Story V(kips)	Sum V(kips)	Panel Shear (plf)	Height/Width Reduction (%) R = 2*L/H	Design Panel Shear (plf)	Wall Type	Wall Mark	Floor DL Trib(ft)	Story DL(klf)	Walls/DL Stacks?	Sum DL(klf)	OTM (k-ft)	RM (k-ft)	Resultant HD(kips)	HD TYPE	HD/Strap to DF or HF?	HD location Edge/Interior?	Resultant HD	Force at Window (Kips)	Window Strap							
B	CONCRETE FOUNDATION																																				
	B1	13.67					13.67	1015.00	0.44	447.58	0.94	5.01	366	1.00	366	SW3	B1	3.00	0.16	YES	0.37	50.5	30.9	1.49	flr-conc	DF-L	Edge	STHD14	0.00	No strap							
	B2	17.33					17.33	1015.00	0.56	567.42	1.19	6.35	366	1.00	366	SW3	B2	8.00	0.22	YES	0.38	64.0	51.3	0.76	flr-conc	DF-L	Edge	STHD14	0.00	No strap							
	CONCRETE FOUNDATION																																				

S = 31.00 Total OSB wall length = 13.67 S = 1015.00 2.13 **11.36** Warning-Wall Total OSB Capacity = 4.64

Project	Granbois	Sheet number:	L7	
Subject	SHEAR WALL EQUATION DIAGRAM		Date	8/22/2024

SHEAR WALL WITH WINDOW BASED ON SHEAR TRANSFER:

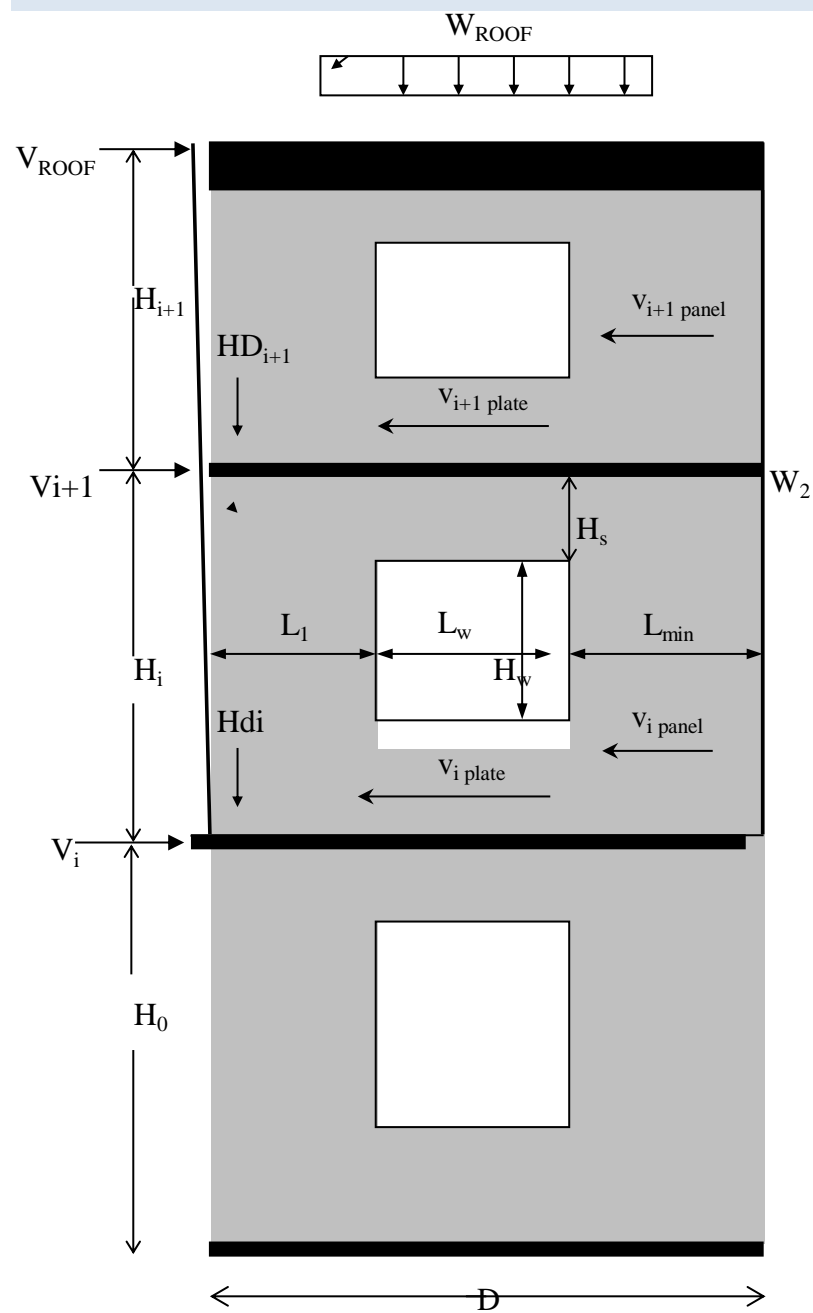

Where:

- V_i = Story Shear
- W_i = Story Dead Load
- HD_i = Story Holddown
- M_{OTi} = Story Over Turning Moment
- M_{Ri} = Story Resisting Moment

$$M_{OT\ ROOF} = V_{ROOF} \times H_{i+1}$$

$$M_{R\ ROOF} = 0.6 \times W_{ROOF} \times D^2/2$$

$$HD_{i+1} = (M_{OT\ ROOF} - M_{R\ ROOF}) / (D - 6")$$

$$V_{i+1\ panel} = V_{ROOF} / (L_1 + L_{max})$$

$$V_{i+1\ plate} = V_{ROOF} / D$$

$$M_{OTi} = [(V_{i+1} + V_{ROOF}) \times H_i] + M_{OT\ ROOF}$$

$$M_{Ri} = 0.6 \times (W_{i+1} + W_{ROOF}) \times D^2/2$$

$$HD_i = (M_{OTi} - M_{Ri}) / (D - 6")$$

$$V_{i\ panel} = (V_{ROOF} + V_{i+1}) / (L_1 + L_{max})$$

$$V_{i\ plate} = (V_{ROOF} + V_{i+1}) / D$$

FORCE TRANSFER AROUND WINDOW CALCULATION (CANTILEVER PIER METHOD)

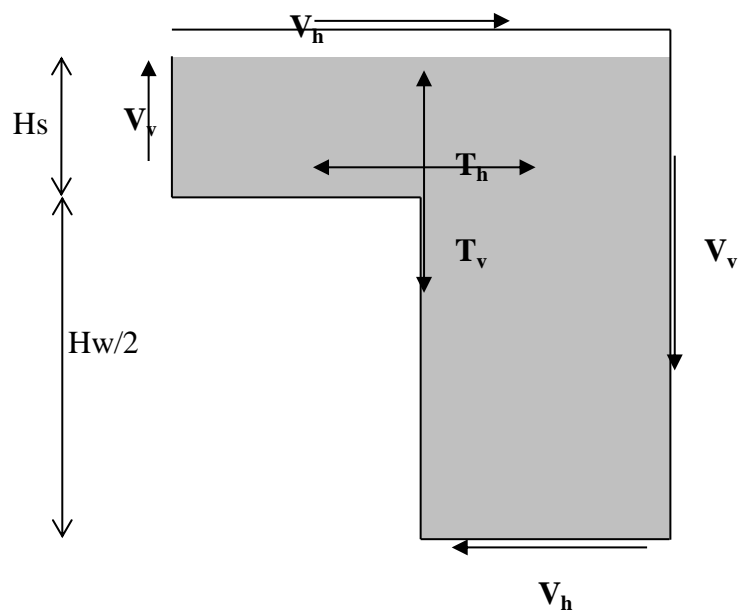

$$V_h = v_{i\ panel} \times L_{max}$$

$$V_v = HD_i$$

$$T_h = V_h (H_w / 2 + H_s) / H_s$$

T_v = Is resisted by the continuous stud adjacent to the window.

Project Number: S230110-1	Plan Name: Granbois	Sheet Number: L8
Engineer: HK	Specifics: Shear wall schedule	Date: 8/22/2024

SHEAR WALL SCHEDULE												
Nailing: 8d		0.131"φ x 2 1/2"		Rim Joist or Blocking Connection to Top Plate Below			2x Plate Attachment	Anchor Bolt Spacing to Concrete Below				Shearwall Capacity (plf)
Framing Species: Hem-Fir		Adjoining and Panel Edge Attachment		Clip Spacing (in)			0.148"φ x 3 1/2" Nailing to Rim Joist or Blocking Below	2x Sill Plate Attachment		3x Sill Plate Attachment		
Wall Type	Sheathing	Nail Spacing	Blocking and Stud Size	Clip Spacing (in)			Bolt Diameter	Bolt Diameter		Bolt Diameter		
				RBC	LTP4	A35		5/8 Ø	3/4 Ø	5/8 Ø	3/4 Ø	
S W6	15/32	6 "o.c.	2x	16	16	16	6	48	48	48	48	240
S W4	15/32	4 "o.c.	2x	12	16	16	4	36	48	48	48	350
S W3	15/32	3 "o.c.	3x	8	16	12	3	16	24	36	48	455
S W2	15/32	2 "o.c.	3x	8	12	8	3	12	16	24	36	595
2 2W4	15/32 Both Sides	4 "o.c.	3x	6	8	8	2	NA	NA	24	36	705
2 2W3	15/32 Both Sides	3 "o.c.	3x	NG	8	6	NG	NA	NA	16	24	910
2 2W2	15/32 Both Sides	2 "o.c.	3x	NG	6	NG	NG	NA	NA	16	16	1190

NOTES:

- [1] INSTALL PANELS EITHER HORIZONTALLY OR VERTICALLY.
- [2] WHERE SHEATHING IS APPLIED ON BOTH SIDES OF WALL, PANEL EDGE JOINTS ON 2X FRAMING SHALL BE STAGGERED SO THAT JOINTS ON THE OPPOSITE SIDES ARE NOT LOCATED ON THE SAME STUDS.
- [3] BLOCKING IS REQUIRED AT ALL PANEL EDGES.
- [4] PROVIDE SHEAR WALL SHEATHING AND NAILING FOR THE ENTIRE LENGTH OF THE WALLS INDICATED ON THE PLANS. ENDS OF FULL HEIGHT WALLS ARE DESIGNATED BY WINDOWS, OR DOORWAYS OR AS DESIGNATED ON PLANS. HOLD-DOWN REQUIREMENTS PER PLANS. (ALTERNATE NOTE: WALLS DESIGNATED AS PERFORATED SHEAR WALLS REQUIRE SHEATHING, SHEAR WALL NAILING, ETC. ABOVE AND BELOW ALL OPENINGS).
- [5] SHEATHING EDGE NAILING IS REQUIRED AT ALL HOLD-DOWN POSTS. EDGE NAILING MAY ALSO BE REQUIRED TO EACH STUD USED IN BUILT-UP HOLD-DOWN POSTS. ADDITIONAL INFORMATION PER HOLD-DOWN DETAILS.
- [6] INTERMEDIATE FRAMING TO BE 2x MINIMUM MEMBERS. ATTACH SHEATHING TO INTERMEDIATE FRAMING WITH 0.131"φ x 2~8" NAILS AT 12" oc WHERE STUDS ARE SPACED AT 16"OC AND 0.131"φ X 2~8" NAILS AT 6" oc WHERE STUDS ARE SPACED AT 24" oc.
- [7] BASED ON 0.131"φ X 1 1/2" NAILS USED TO ATTACH FRAMING CLIPS DIRECTLY TO FRAMING. USE 0.131"φ X 2 1/2" NAILS WHERE INSTALLED OVER SHEATHING. 2 1/2" NAILS ONLY APPLICABLE INTO NARROW FACE OF TOP PLATES, NOT APPLICABLE INTO FACE OF SINGLE PLY RIM
- [8] FRAMING CLIPS: A35 OR LTP5 OR APPROVED EQUIVALENT.
- [9] WHERE BOTTOM PLATE ATTACHMENT SPECIFIES (2) ROWS OF NAILS, PROVIDE DOUBLE JOIST, RIM JOIST OR EQUAL BELOW. STAGGER NAILS IN ROWS 1 - 1/2" APART MINIMUM.
- [10] ANCHOR BOLTS SHALL BE PROVIDED WITH HOT DIPPED GALVANIZED STEEL PLATE WASHERS 0.229" x 3" x 3" MIN. THE HOLE IN THE PLATE WASHER MAY BE DIAGONALLY SLOTTED 13/16" x 1 - 3/4" PROVIDED A STANDARD CUT WASHER IS PLACED BETWEEN THE PLATE WASHER AND NUT. PLATE WASHER TO EXTEND TO WITHIN 1/2" OF THE EDGE OF THE SILL PLATE ON THE SIDE(S) WITH SHEATHING. INCREASE PLATE WASHER SIZE AS REQUIRED. EMBED ANCHOR BOLTS 7" MINIMUM INTO THE CONCRETE.
- [11] PRESSURE TREATED MATERIAL CAN CAUSE EXCESSIVE CORROSION IN THE FASTENERS. PROVIDE HOT-DIPPED GALVANIZED (ELECTRO-PLATING IS NOT ACCEPTABLE) NAILS AND CONNECTOR PLATES (FRAMING ANGLES, ETC.) FOR ALL CONNECTORS IN CONTACT WITH PRESSURE TREATED FRAMING MEMBERS. ADDITIONAL INFORMATION PER STRUCTURAL NOTES.
- [12] 7/16" APA-RATED SHEATHING (OSB) MAY BE USED IN PLACE OF 15/32" SHEATHING PROVIDED THAT ALL STUDS ARE SPACED AT 16"OC MAXIMUM.
- [14] AT ADJOINING PANEL EDGES, (2) 2x STUDS NAILED TOGETHER MAY BE USED IN PLACE OF SINGLE 3x STUD. DOUBLE 2x STUDS SHALL BE CONNECTED TOGETHER BY NAILING THE STUDS TOGETHER WITH 3" LONG NAILS OF THE SAME SPACING AND DIAMETER AS THE PLATE NAILING, PER SECTION.
- [15] CONTACT THE STRUCTURAL ENGINEER OF RECORD FOR ADHESIVE OR EXPANSION BOLT ALTERNATIVES TO CAST-IN-PLACE ANCHOR BOLTS. SPECIAL INSPECTION MAY BE REQUIRED.
- [16] NAIL STUDS TO 3x SILL PLATES WITH EITHER (2) 0.148"φ x 4" END NAILS OR (4) 0.131"φ x 2 - 1/2" TOENAILS.
- [17] **SWX** WHERE "W" INDICATES WOOD SHEATHING AND "X" INDICATES EDGE NAIL SPACING.

COMBINED LTP & A35 CLIP AT BOTH SIDES OF RIM/BLKG AS SPEC'D PER SHEARWALL SCHED.

Shearwall Capacity (kips)				
Shearwall Callout	Nails: 0.131"φ x 2 ¹ / ₂ "		0.148"φ x 2 ¹ / ₂ "	
	Hem-Fir	Doug-Fir	Hem-Fir	Doug-Fir
W6	240	260	290	310
W4	350	350	430	460
W3	455	490	560	600
W2	595	640	715	770
2W4	705	760	855	920
2W3	910	980	1120	1200
2W2	1190	1280	1430	1540

ASD Allowable Loads - Data Table			
Connector	Hem-Fir	Doug-Fir	Notes
RBC	420	485	Wind or earthquake loads
LTP4	615	715	Wind or earthquake loads
A35	515	600	Wind or earthquake loads (avg of clip load orientation into side grain parallel and perpendicular)
Z - 16d common through 2x	150	170	C _D =1.6 Cd=.77 (3/4 ply assumed)
Z - 10d common through 2x	163	184	C _D =1.6 Factor included
5/8 Ø to 2x plate	1376	1472	C _D =1.6 Factor included
3/4 Ø to 2x plate	1920	2016	C _D =1.6 Factor included
5/8 Ø to 3x plate	1712	1872	C _D =1.6 Factor included
3/4 Ø to 3x plate	2240	2432	C _D =1.6 Factor included

SHEARWALL SCHEDULE WITH LP NOVACORE 1 7/16" (R-5) SYSTEM					COMMENTS
WALL MARK	SHEATHING	PANEL EDGE NAILING	RIM CONNECTION & SILL PLATE ANCHORAGE PER TYPICAL SCHEDULE	SHEAR CAPACITY (PLF)	
SW6	1-7/16" (R-5) LP NOVACORE SHTNG	3"x0.131"x0.281" @ 4" OC	SEE TYP SCHED.	245	SEE APA REPORT FOR APPROVED SHEAR CAPACITIES
SW4	1-7/16" (R-5) LP NOVACORE SHTNG	3"x0.131"x0.281" @ 3" OC	SEE TYP SCHED.	280	SEE APA REPORT FOR APPROVED SHEAR CAPACITIES
2W4/6	1-7/16" (R-5) LP NOVACORE SHTNG OUTSIDE & 7/16" APA PLY/OSB INSIDE	3"x0.131"x0.281" @ 4" OC AT NOVACORE 1 1/2"x0.131" @ 6" OC AT TYPICAL PLY	SEE TYP SCHED. FOR '2W4'	480	COMBINED SHEAR CAPACITY = 245 PLF + 240 PLF
2W3/3	1-7/16" (R-5) LP NOVACORE SHTNG OUTSIDE & 7/16" APA PLY/OSB INSIDE	3"x0.131"x0.281" @ 3" OC AT NOVACORE 1 1/2"x0.131" @ 3" OC AT TYPICAL PLY	SEE TYP SCHED. FOR '2W3'	735	COMBINED SHEAR CAPACITY = 280 PLF + 455 PLF

SHEAR WALL CALCULATIONS							
Rim Joist or Blocking Connection to Top Plate Below			2x Plate Attachment	Anchor Bolt Spacing to Concrete Below			
			0.148"φ x 3 1/2" Nailing to Rim Joist or Blocking Below	2x Sill Plate Attachment		3x Sill Plate Attachment	
Clip Spacing (in)				Bolt Diameter		Bolt Diameter	
RBC	LTP4	A35		5/8 Ø	3/4 Ø	5/8 Ø	3/4 Ø
21.0	21.0	21.0	7.5	68.8	96.0	85.6	112.0
14.4	14.4	14.4	5.2	47.2	65.8	58.7	76.8
11.1	11.1	11.1	4.0	18.1	25.3	45.2	59.1
8.5	8.5	8.5	3.0	13.9	19.4	34.5	45.2
7.1	7.1	7.1	2.6	NA	NA	29.1	38.1
5.5	5.5	5.5	2.0	NA	NA	22.6	29.5
4.2	6.2	5.2	1.5	NA	NA	17.3	22.6

LP NovaCore[®] Thermal Insulated Sheathing
Louisiana-Pacific Corporation

PR-N139

Revised March 30, 2024

Product: LP NovaCore[®] Thermal Insulated Sheathing
Louisiana-Pacific Corporation, 1610 West End Ave., Suite 200, Nashville, TN 37203
(888) 820-0325
www.lpcorp.com

1. Basis of the product report:

- 2021, 2018, and 2015 International Building Code (IBC): Sections 104.11 Alternative materials and 2303.1.5 Wood structural panels
- 2012 IBC: Sections 104.11 Alternative materials and 2303.1.4 Wood structural panels
- 2021, 2018, 2015, and 2012 International Residential Code (IRC): Sections R104.11 Alternative materials and R503.2 Wood structural panel sheathing
- DOC PS 2-18, Performance Standard for Wood Structural Panels
- APA Reports T2022P-06, T2022P-13, T2023P-12, T2023P-13, and T2024P-10, and other qualification data

2. Product description:

LP NovaCore[®] Thermal Insulated Sheathing is an insulated sheathing made by combining 7/16 Category OSB with a layer of R-5 per inch XPS rigid foam insulation laminated to the OSB with a non-structural polyvinyl acetate (PVA) adhesive. The OSB complies with DOC PS 2 in accordance with the in-plant manufacturing standard approved by APA.

LP NovaCore Thermal Insulated Sheathing is available in net thicknesses of 15/16, 1-7/16, and 1-15/16 inches, and 4x8-foot, 4x9-foot, and 4x10-foot nominal panel sizes with square edges. The XPS foam specification and the PVA glue bond applications are specified in the in-plant manufacturing standard but are beyond the scope of the APA certification.

3. Design properties:

- 3.1 Intermittent Wall Bracing (WSP Method): Table 1 lists the LP NovaCore Thermal Insulated Sheathing prescriptive nailing requirements for use as the intermittent wall bracing in accordance with Section R602.10 of the IRC and Section 2308.6 of the 2021, 2018, and 2015 IBC, and Section 2308.3 of the 2012 IBC. Segments of the wall with openings shall not be counted as the length of wall bracing for the WSP intermittent wall bracing method.
- 3.2 Engineered Shear Wall: Tables 2A and Table 2B list the LP NovaCore Thermal Insulated Sheathing in-plane nominal unit shear capacities for engineering design in accordance with Section 2305 of the IBC and ANSI/AWC Special Design Provisions for Wind and Seismic (SDPWS) for wood structural panel shear walls unless otherwise specified in this report. The seismic design coefficients and factors shall be in accordance with the ASCE-7 Bearing Wall Systems for light-frame wood walls sheathed with wood structural panels (Item 15) with the maximum shear wall aspect ratio of 2:1. Segments of the wall with openings shall not be counted as a shear wall.

4. Product installation:

LP NovaCore Thermal Insulated Sheathing recognized in this report shall be installed with the foam direct to studs and used in accordance with the recommendations provided by the

manufacturer (<https://lpcorp.com/resources/product-literature/installation-instructions/lp-novacore-installation-instructions>).

5. Limitations:

- a) LP NovaCore Thermal Insulated Sheathing recognized in Section 3.1 of this report shall be permitted for use as prescriptive intermittent wall bracing in Seismic Design Categories (SDC) A, B, and C (excluding townhouses in SDC C) and in regions where wind design is not required by Section R301.2.1.1 of the IRC when installed in accordance with the requirements specified in this report and the recommendations provided by the manufacturer.
- b) LP NovaCore Thermal Insulated Sheathing recognized in Section 3.2 of this report shall be permitted for use as shear walls in any Seismic Design Categories as permitted in Section 2305 of the IBC when installed in accordance with the requirements specified in this report and the recommendations provided by the manufacturer.
- c) LP NovaCore Thermal Insulated Sheathing is limited to dry service conditions that result in the average equilibrium moisture content of sawn lumber of less than 16%.
- d) LP NovaCore Thermal Insulated Sheathing shall be covered with a water-resistive barrier on the exterior of the OSB sheathing in accordance with the code.
- e) An approved thermal barrier, such as minimum 1/2-inch gypsum wallboard, shall be installed on the interior side of the wall framing, opposite the LP NovaCore Thermal Insulated Sheathing, in accordance with Section R316.4 of the IRC or Section 2603.4 of the IBC.
- f) Fire resistance of LP NovaCore Thermal Insulated Sheathing is beyond the scope of this report.
- g) The 1/2-inch thick (R-3), 1-inch thick (R-5), and 1-1/2-inch thick (R-7.5) XPS foam insulation is supplied by a foam manufacturer in accordance with the in-plant manufacturing standard and its certification is beyond the scope of this report.
- h) The 7/16 Category OSB sheathing is manufactured at the LP facilities in Thomasville, Alabama (APA assigned plant number 520) and Peace Valley, British Columbia, Canada (APA assigned plant number 510), and certified by APA.
- i) This report is subject to re-examination in one year.

6. Identification:

The NovaCore Thermal Insulated Sheathing described in this report is identified by a label bearing the manufacturer's name (Louisiana-Pacific Corporation) and/or trademark, the report number PR-N139, and a means of identifying the date of manufacture.

Table 1. Intermittent Wall Bracing Nailing Requirements for LP NovaCore Thermal Insulated Sheathing in Accordance with the 2021, 2018, 2015, and 2012 IRC (WSP Method)

Foam Thickness (in)	Framing ^(a)		Nailing Requirement		
	Nominal Stud Size (Min.)	Max. Stud Spacing (in.)	Min. Nail Size Nail Size Length x Shank Dia. x Head Dia. (in.) ^(b,c,d)	Max. Nail Spacing Edge ^(e) /Field (in.)	Min. Penetration into Framing (in.)
1/2	2 x 4	24	2-1/2 x 0.131 x 0.281	4/12	1.5
1	2 x 4	24	3 x 0.131 x 0.281	4/12	1.5
1-1/2	2 x 4	24	3-1/2 x 0.131 x 0.281	3/12	1.5

For SI: 1 inch = 25.4 mm, 1 foot = 304.8 mm, 1 lbf = 0.454 kg, 1 psi = 6.9 kPa

- ^(a) All panel edges must be backed by framing or blocking. Exception: When not used as bracing panels, the horizontal edges may be left unblocked.
- ^(b) Nails must be full round head of a type generally used to attach wood structural panel sheathing.
- ^(c) Offset round head nails of equivalent size shall be permitted to be substituted provided the nails are included in ICC-ES Evaluation Report ESR-1539 and meet the Head Area Ratio (HAR) requirements of a nail having a shank diameter of at least 0.131 in. (e.g., Y =8d equivalent to an 8d common nail with a shank diameter of 0.131 in., or Y 135 for a nail having a shank diameter of 0.135 in.).
- ^(d) All nails must be "bright" carbon steel or galvanized of equivalent or larger size.
- ^(e) All panel edge nails must be located approximately 3/8 inch from panel edges except at the corner of a brace wall line, in which the recommendation by the manufacturer shall be followed.

Table 2A. Nominal Unit Shear Capacities for Douglas fir-Larch Wood-Framed Shear Walls Sheathed with LP NovaCore Insulated Sheathing Using Standard Full-Round Head Nails^(a,b,c,d,e,f)

Net Panel Thickness (in.)	Min. Nail Penetration into Framing (in.)	Nail Size Length x Shank Dia. x Head Dia. (in.)	Nail Spacing Edge/Field (in.)	Nominal Unit Shear Capacity (lbf/ft)	Apparent Shear Stiffness, G_a (kips/in.)
15/16	1.5	2-1/2 x 0.131 x 0.281	3/12	840	9.6
			4/12	730	7.2
1-7/16	1.5	3 x 0.131 x 0.281	3/12	785	5.6
			4/12	685	5.1
1-15/16	1.5	3-1/2 x 0.131 x 0.281	3/12	730	3.2

For SI: 1 inch = 25.4 mm, 1lbf/ft = 14.59 N/m; 1 kips/in. = 1.216 N/m

- For seismic design, the allowable stress design (ASD) allowable shear capacity shall be determined by dividing the tabulated nominal shear capacity by the ASD reduction factor of 2.8 and the LRFD factored shear resistance shall be determined by multiplying the nominal shear capacity by a resistance factor, ϕ_D , of 0.50. No further increases shall be permitted.
- For wind design, the ASD allowable shear capacity shall be determined by dividing the tabulated nominal shear capacity by the ASD reduction factor of 2.0 and the LRFD factored shear resistance shall be determined by multiplying the nominal shear capacity by a resistance factor, ϕ_D , of 0.80. No further increases shall be permitted.
- Values assume Douglas fir-Larch lumber at 19% or less moisture content at the time of fabrication.
- When species of framing lumber other than Douglas fir-Larch are used, reduce nominal unit shear capacity by multiplying the tabulated value by the Specific Gravity Adjustment Factor = $(1-(0.50-G)) \leq 1.0$, where G = specific gravity of the framing lumber from NDS Table 12.3.3A.
- All panel edges shall be backed by framing or blocking, and nails shall be located approximately 3/8 inch from panel edges except at the corner of a brace wall line, in which the recommendation by the manufacturer shall be followed.
- Shear wall deflection shall be determined in accordance with SDPWS using the G_a value provided in this table.

Table 2B. Nominal Unit Shear Capacities for Douglas fir-Larch Wood-Framed Shear Walls Sheathed with LP NovaCore Insulated Sheathing Using Nails with Offset Round Heads^(a,b,c,d,e,f)

Net Panel Thickness (in.) ^(g)	Min. Nail Penetration into Framing (in.)	Nail Size Length x Shank Dia. (in.) x Min. Head Area Ratio (HAR) ^(g)	Nail Spacing Edge/Field (in.)	Nominal Unit Shear Capacity (lbf/ft)	Apparent Shear Stiffness, G_a (kips/in.)
15/16	1.5	2-1/2 x 0.131 x Y =8d	3/12	785	8.9
			4/12	685	6.7
1-7/16	1.5	3 x 0.131 x Y =8d	3/12	730	5.1
			4/12	645	4.7
1-15/16	1.5	3-1/2 x 0.131 x Y =8d	3/12	670	2.6

For SI: 1 inch = 25.4 mm, 1lbf/ft = 14.59 N/m; 1 kips/in. = 1.216 N/m

- For seismic design, the allowable stress design (ASD) allowable shear capacity shall be determined by dividing the tabulated nominal shear capacity by the ASD reduction factor of 2.8 and the LRFD factored shear resistance shall be determined by multiplying the nominal shear capacity by a resistance factor, ϕ_D , of 0.50. No further increases shall be permitted.
- For wind design, the ASD allowable shear capacity shall be determined by dividing the tabulated nominal shear capacity by the ASD reduction factor of 2.0 and the LRFD factored shear resistance shall be determined by multiplying the nominal shear capacity by a resistance factor, ϕ_D , of 0.80. No further increases shall be permitted.
- Values assume Douglas fir-Larch lumber at 19% or less moisture content at the time of fabrication.
- When species of framing lumber other than Douglas fir-Larch are used, reduce nominal unit shear capacity by multiplying the tabulated value by the Specific Gravity Adjustment Factor = $(1-(0.50-G)) \leq 1.0$, where G = specific gravity of the framing lumber from NDS Table 12.3.3A.
- All panel edges shall be backed by framing or blocking, and nails shall be located approximately 3/8 inch from panel edges except at the corner of a brace wall line, in which the recommendation by the manufacturer shall be followed.
- Shear wall deflection shall be determined in accordance with SDPWS using the G_a value provided in this table.
- Offset round head nails included in ICC-ES Evaluation Report ESR-1539 and meet the Head Area Ratio (HAR) requirements of a nail having a shank diameter of at least 0.131 in. (e.g., Y =8d for an 8d common nail with a shank diameter of 0.131 in., or Y 135 for a nail having a shank diameter of 0.135 in.).

APA – *The Engineered Wood Association* is an approved national standards developer accredited by American National Standards Institute (ANSI). APA publishes ANSI standards and Voluntary Product Standards for wood structural panels and engineered wood products. APA is an accredited certification body under ISO/IEC 17065 by Standards Council of Canada (SCC), an accredited inspection agency under ISO/IEC 17020 by International Code Council (ICC) International Accreditation Service (IAS), and an accredited testing organization under ISO/IEC 17025 by IAS. APA is also an approved Product Certification Agency, Testing Laboratory, Quality Assurance Entity, Validation Entity, and Product Evaluation Entity by the State of Florida, and an approved testing laboratory by City of Los Angeles.

**APA – THE ENGINEERED WOOD ASSOCIATION
HEADQUARTERS**

7011 So. 19th St. • Tacoma, Washington 98466
Phone: (253) 565-6600 • Fax: (253) 565-7265 • Internet Address: www.apawood.org

PRODUCT SUPPORT HELP DESK
(253) 620-7400 • E-mail Address: help@apawood.org

DISCLAIMER

APA Product Report® is a trademark of APA – *The Engineered Wood Association*, Tacoma, Washington. The information contained herein is based on the product evaluation in accordance with the references noted in this report. No warranties, express or implied, including as to fitness for a particular purpose, are made regarding this report. Neither APA nor its members shall be liable, or assume any legal liability or responsibility, for damages, direct or indirect, arising from the use, application of, and/or reference to opinions, findings, conclusions or recommendations included in this report. Consult your local jurisdiction or design professional to assure compliance with code, construction, and performance requirements. Because APA has no control over quality of workmanship or the conditions under which engineered wood products are used, it cannot accept responsibility for product performance or designs as actually constructed.

Project Number: S230110-1	Plan Name: Granbois	Sheet Number: L10
Engineer: HK	Specifics: Tank wall design (plate design)	Date: 4/19/2024

Vertical Height (a) = 12.0 ft	Wall Thickness (t) = 10 in
Horizontal Unbraced Length (b) = 8.0 ft	Effective Depth (d) = 6 in
Wall Aspect Ratio (b/a) = 0.67	Active Earth Pressure (Pa) = 100 pcf

PLATE COEFFICIENTS							
<i>(Side = Fixed, Top = Free, Bottom = Hinged Condition)</i>							
Wall Aspect Ratio b / a	Wall Section x / a	y = 0		y = b / 4		y = b / 2	
		Mx	My	Mx	My	Mx	My
0.5	TOP	0.000	0.002	0.000	0.000	0.000	-0.003
	1/4	0.000	0.004	0.001	0.001	-0.001	-0.005
	1/2	0.002	0.006	0.002	0.002	-0.002	-0.010
	3/4	0.007	0.008	0.002	0.002	-0.003	-0.014
0.67	TOP	0.000	0.004	0.000	0.001	0.000	-0.006
	1/4	0.001	0.007	0.000	0.002	-0.002	-0.010
	1/2	0.004	0.009	0.002	0.003	-0.003	-0.018
	3/4	0.009	0.011	0.004	0.003	-0.004	-0.022
0.75	TOP	0.000	0.005	0.000	0.001	0.000	-0.008
	1/4	0.001	0.008	0.000	0.002	-0.003	-0.013
	1/2	0.005	0.011	0.002	0.004	-0.004	-0.022
	3/4	0.010	0.012	0.005	0.004	-0.005	-0.026

VERTICAL REINFORCEMENT AT CORNER (Y = 0)							
Wall Section x / a	Coefficient C	Moment Mx = C*Pa*a ³ (kip - ft)	Ult. Moment Mux = 1.6*Mx (kip - ft)	As Required As = Mux / 4d (in ² / ft)	Rebar Size	Rebar Spacing (in)	Provided As (in ² / ft)
TOP	0.0000	0.000	0.000	0.000	# 4	12	0.200
1/4	0.0007	0.115	0.184	0.008	# 4	12	0.200
1/2	0.0040	0.691	1.106	0.046	# 4	12	0.200
3/4	0.0090	1.555	2.488	0.104	# 4	12	0.200

VERTICAL REINFORCEMENT CENTER (Y = 1 / 2)							
Wall Section x / a	Coefficient C	Moment Mx = C*Pa*a ³ (kip - ft)	Ult. Moment Mux = 1.6*Mx (kip - ft)	As Required As = Mux / 4d (in ² / ft)	Rebar Size	Rebar Spacing (in)	Provided As (in ² / ft)
TOP	0.000	0.000	0.000	0.000	# 4	12	0.200
1/4	-0.002	-0.403	-0.645	0.027	# 4	12	0.200
1/2	-0.003	-0.576	-0.922	0.038	# 4	12	0.200
3/4	-0.004	-0.749	-1.198	0.050	# 4	12	0.200

HORIZONTAL REINFORCEMENT AT CORNER (Y = 0)							
Wall Section x / a	Coefficient C	Moment My = C*Pa*a ³ (kip - ft)	Ult. Moment Muy = 1.6*My (kip - ft)	As Required As = Muy / 4d (in ² / ft)	Rebar Size	Rebar Spacing (in)	Provided As (in ² / ft)
TOP	0.004	0.691	1.106	0.046	# 4	12	0.200
1/4	0.007	1.152	1.843	0.077	# 4	12	0.200
1/2	0.009	1.613	2.580	0.108	# 4	12	0.200
3/4	0.011	1.843	2.949	0.123	# 4	12	0.200

HORIZONTAL REINFORCEMENT CENTER (Y = 1 / 2)							
Wall Section x / a	Coefficient C	Moment My = C*Pa*a ³ (kip - ft)	Ult. Moment Muy = 1.6*My (kip - ft)	As Required As = Muy / 4d (in ² / ft)	Rebar Size	Rebar Spacing (in)	Provided As (in ² / ft)
TOP	-0.006	-1.094	-1.751	0.073	# 4	6	0.400
1/4	-0.010	-1.786	-2.857	0.119	# 4	6	0.400
1/2	-0.018	-3.110	-4.977	0.207	# 4	6	0.400
3/4	-0.022	-3.802	-6.083	0.253	# 4	6	0.400

Project Number: S230110-1	Plan Name: Granbois	Sheet Number: L10
Engineer: HK	Specifics: Window Well Wall design (plate design)	Date: 4/19/2024

Vertical Height (a) = 6.0 ft	Wall Thickness (t) = 6 in
Horizontal Unbraced Length (b) = 9.0 ft	Effective Depth (d) = 4 in
Wall Aspect Ratio (b/a) = 1.50	Active Earth Pressure (Pa) = 60 pcf

PLATE COEFFICIENTS							
<i>(Side = Fixed, Top = Free, Bottom = Hinged Condition)</i>							
Wall Aspect Ratio b / a	Wall Section x / a	y = 0		y = b / 4		y = b / 2	
		Mx	My	Mx	My	Mx	My
1.25	TOP	0.000	0.017	0.000	0.003	0.000	-0.034
	1/4	0.005	0.020	0.002	0.005	-0.008	-0.042
	1/2	0.017	0.023	0.009	0.009	-0.010	-0.045
	3/4	0.021	0.017	0.013	0.009	-0.009	-0.044
1.50	TOP	0.000	0.027	0.000	0.005	0.000	-0.052
	1/4	0.009	0.028	0.003	0.008	-0.012	-0.059
	1/2	0.022	0.027	0.012	0.011	-0.013	-0.063
	3/4	0.027	0.020	0.017	0.011	-0.010	-0.052
1.5	TOP	0.000	0.027	0.000	0.005	0.000	-0.052
	1/4	0.009	0.028	0.003	0.008	-0.012	-0.059
	1/2	0.022	0.027	0.012	0.011	-0.013	-0.063
	3/4	0.027	0.020	0.017	0.011	-0.010	-0.052

VERTICAL REINFORCEMENT AT CORNER (Y = 0)							
Wall Section x / a	Coefficient C	Moment $M_x = C * P_a * a^3$ (kip - ft)	Ult. Moment $M_{ux} = 1.6 * M_x$ (kip - ft)	As Required $A_s = M_{ux} / 4d$ (in ² / ft)	Rebar Size	Rebar Spacing (in)	Provided As (in ² / ft)
TOP	0.0000	0.000	0.000	0.000	# 4	12	0.200
1/4	0.0090	0.117	0.187	0.012	# 4	12	0.200
1/2	0.0220	0.285	0.456	0.029	# 4	12	0.200
3/4	0.0270	0.350	0.560	0.035	# 4	12	0.200

VERTICAL REINFORCEMENT CENTER (Y = 1 / 2)							
Wall Section x / a	Coefficient C	Moment $M_x = C * P_a * a^3$ (kip - ft)	Ult. Moment $M_{ux} = 1.6 * M_x$ (kip - ft)	As Required $A_s = M_{ux} / 4d$ (in ² / ft)	Rebar Size	Rebar Spacing (in)	Provided As (in ² / ft)
TOP	0.000	0.000	0.000	0.000	# 4	12	0.200
1/4	-0.012	-0.156	-0.249	0.016	# 4	12	0.200
1/2	-0.013	-0.168	-0.270	0.017	# 4	12	0.200
3/4	-0.010	-0.130	-0.207	0.013	# 4	12	0.200

HORIZONTAL REINFORCEMENT AT CORNER (Y = 0)							
Wall Section x / a	Coefficient C	Moment $M_y = C * P_a * a^3$ (kip - ft)	Ult. Moment $M_{uy} = 1.6 * M_y$ (kip - ft)	As Required $A_s = M_{uy} / 4d$ (in ²)	Rebar Size	Rebar Spacing (in)	Provided As (in ² / ft)
TOP	0.027	0.350	0.560	0.035	# 4	12	0.200
1/4	0.028	0.363	0.581	0.036	# 4	12	0.200
1/2	0.027	0.350	0.560	0.035	# 4	12	0.200
3/4	0.020	0.259	0.415	0.026	# 4	12	0.200

HORIZONTAL REINFORCEMENT CENTER (Y = 1 / 2)							
Wall Section x / a	Coefficient C	Moment $M_y = C * P_a * a^3$ (kip - ft)	Ult. Moment $M_{uy} = 1.6 * M_y$ (kip - ft)	As Required $A_s = M_{uy} / 4d$ (in ²)	Rebar Size	Rebar Spacing (in)	Provided As (in ² / ft)
TOP	-0.052	-0.674	-1.078	0.067	# 4	6	0.400
1/4	-0.059	-0.765	-1.223	0.076	# 4	6	0.400
1/2	-0.063	-0.816	-1.306	0.082	# 4	6	0.400
3/4	-0.052	-0.674	-1.078	0.067	# 4	6	0.400



LONGITUDE
ONE TWENTY°
ENGINEERING & DESIGN

Foundation Design

DATE:	08/19/2024	COMPANY:	L120 Engineering & Design, LLC
VITRUVIUS BUILD:	StruCalc	DESIGNED BY:	Mans Thurfjell
CUSTOMER:		REVIEWED BY:	Mans Thurfjell
PROJ. ADDRESS:	--	PROJECT NAME:	2018 fnd 3000 psf
	--		
LEVEL:	Basement	LOADING:	
MEMBER NAME:	16in cont ftg	CODE:	2018 International Building Code
MEMBER TYPE:	CONTINUOUS FOOTING	ACI:	ACI 318-19
MATERIAL:	Concrete		
1.33 (ft) Wide X 10 (in) Deep		Soil Depth TOF: 0 (ft)	
		Longit: (2) #4 Bars	

16in cont ftg DIAGRAMS

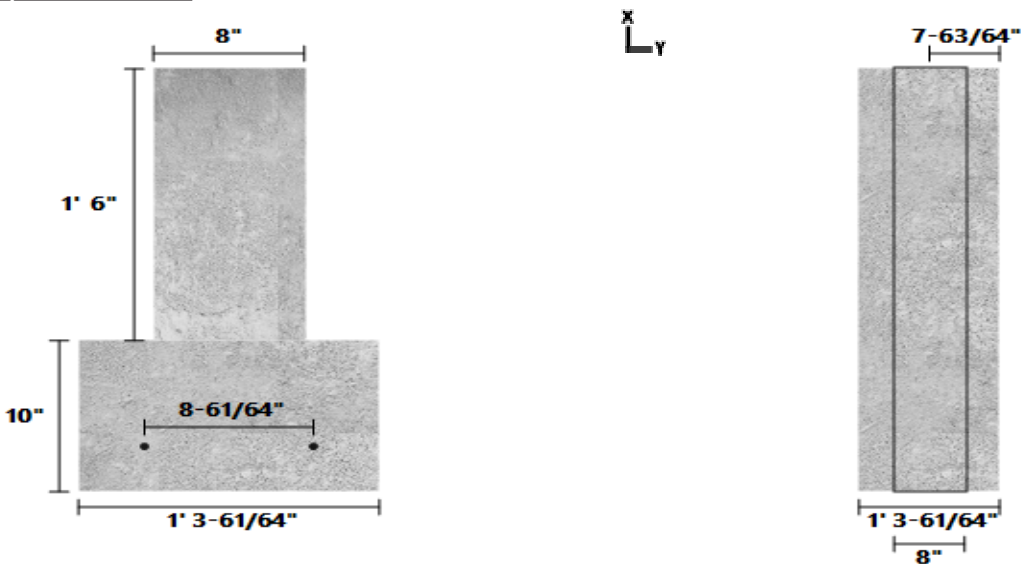

MATERIAL PROPERTIES

FOOTING					
fc' (psi)	Ec (psi)	Density (lb/ft ³)	Width (ft)	Depth (in)	
2500	2880952	145	1.33	10	
STEM WALL					
Width (in)	Height (in)	Material	Offset (in)		
8	18	Concrete	0		
SOIL					
Bearing Strength (lb/ft ²)	Density (lb/ft ³)	Cohesion	Friction Angle	Depth (ft)	Rankine Coefficient (Kp)
3000	140	0	30	0	0
REBAR					
Bar Size #	Transv. Spacing (in)	# Longit. Bars	fy (psi)	Es (psi)	
4	None	2	40000	2.9E+07	

PASS-FAIL

	PASS/FAIL	MAGNITUDE	STRENGTH	LOAD COMBO
Soil Bearing Pressure (lb/ft ²)	PASS (1.1%)	2966.2	3000.0	D+L
One-Way Shear Y (lb/ft)	PASS (91.2%)	513.2	5850.0	1.2D+1.6L+0.5Lr
Moment Y (lb-ft)	PASS (42.5%)	920.0	1600.0	1.2D+1.6L+0.5Lr

LOAD LIST

Type	Left Magnitude	Right Magnitude	Load Start (ft)	Load End (ft)	Load Type	Direction
Uniform (lb/ft)	1800	1800	0	1	Dead	Z
Uniform (lb/ft)	2000	2000	0	1	Live	Z
Stemwall Weight (lb/ft)	145	145	0	1	Dead	Z

DATE:	08/19/2024	COMPANY:	L120 Engineering & Design, LLC
VITRUVIUS BUILD:	StruCalc	DESIGNED BY:	Mans Thurfjell
CUSTOMER:		REVIEWED BY:	Mans Thurfjell
PROJ. ADDRESS:	--	PROJECT NAME:	2018 fnd 3000 psf
	--		
LEVEL:	Basement	LOADING:	
MEMBER NAME:	30x30x12	CODE:	2018 International Building Code
MEMBER TYPE:	ISOLATED FOOTING	ACI:	ACI 318-19
MATERIAL:	Concrete		
2.5 (ft) X 2.5 (ft) X 12 (in)		Soil Depth TOF: 0 (ft)	(4) #4 Long, (4) #4 Short

30x30x12 DIAGRAMS

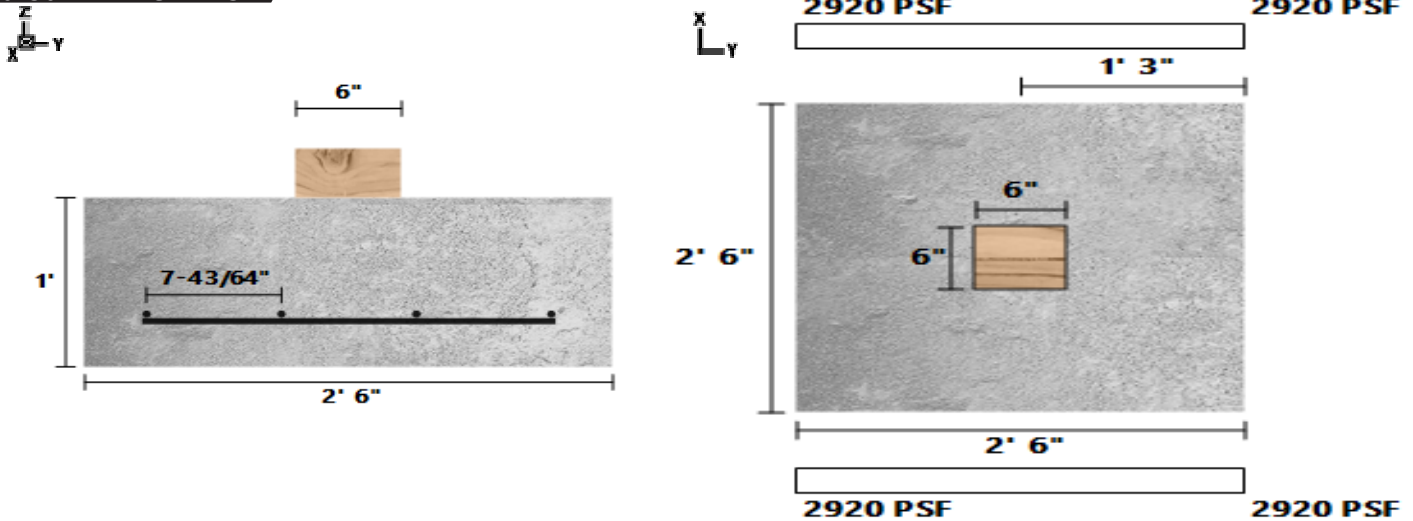

MATERIAL PROPERTIES

FOOTING						
fc' (psi)	Ec (psi)	Density (lbf/ft ³)	Width (ft)	Length (ft)	Depth (in)	Volume (ft ³)
2500	2880952	145	2.5	2.5	12	6.25
CALCULATION VARIABLES						
Bo (in)	Φ-X	Φ-Y				
58	0	0				
COLUMN						
Width (in)	Length (in)	Material	Offset (in)			
6	6	Wood	0			
SOIL						
Bearing Strength (lbf/ft ²)	Density (lbf/ft ³)	Cohesion	Friction Angle	Depth (ft)	Rankine Coefficient (Kp)	
3000	140	0	30	0	3	
REBAR						
Bar Size #	# Bars Long	# Bars Short	fy (psi)	Es (psi)		
4	4	4	40000	2.9E+07		

PASS-FAIL

	PASS/FAIL	MAGNITUDE	STRENGTH	LOAD COMBO
Soil Bearing Pressure (lbf/ft ²)	PASS (2.7%)	2920.0	3000.0	D+L
Two-Way Shear (Punching) (lbf)	PASS (65.4%)	25600.0	73950.0	1.2D+1.6L+0.5Lr
One-Way Shear X (lbf)	PASS (84.4%)	2986.7	19125.0	1.2D+1.6L+0.5Lr
Moment X (lbf-ft)	PASS (18.1%)	5120.0	6250.0	1.2D+1.6L+0.5Lr
One-Way Shear Y (lbf)	PASS (84.4%)	2986.7	19125.0	1.2D+1.6L+0.5Lr
Moment Y (lbf-ft)	PASS (18.1%)	5120.0	6250.0	1.2D+1.6L+0.5Lr
Crushing (psi)	PASS (48.5%)	711.1	1381.3	1.2D+1.6L+0.5Lr

LOAD LIST

Type	Left Magnitude	Right Magnitude	Load Start (ft)	Load End (ft)	Load Type	Direction
Point (lbf)	9000	-	0	-	Dead	Z
Point (lbf)	9250	-	0	-	Live	Z

DATE:	08/19/2024	COMPANY:	L120 Engineering & Design, LLC
VITRUVIUS BUILD:	StruCalc	DESIGNED BY:	Mans Thurfjell
CUSTOMER:		REVIEWED BY:	Mans Thurfjell
PROJ. ADDRESS:	-- --	PROJECT NAME:	2018 fnd 3000 psf
LEVEL:	Basement	LOADING:	
MEMBER NAME:	36x36x12	CODE:	2018 International Building Code
MEMBER TYPE:	ISOLATED FOOTING	ACI:	ACI 318-19
MATERIAL:	Concrete		
3 (ft) X 3 (ft) X 12 (in)		Soil Depth TOF: 0 (ft)	(5) #4 Long, (5) #4 Short

36x36x12 DIAGRAMS

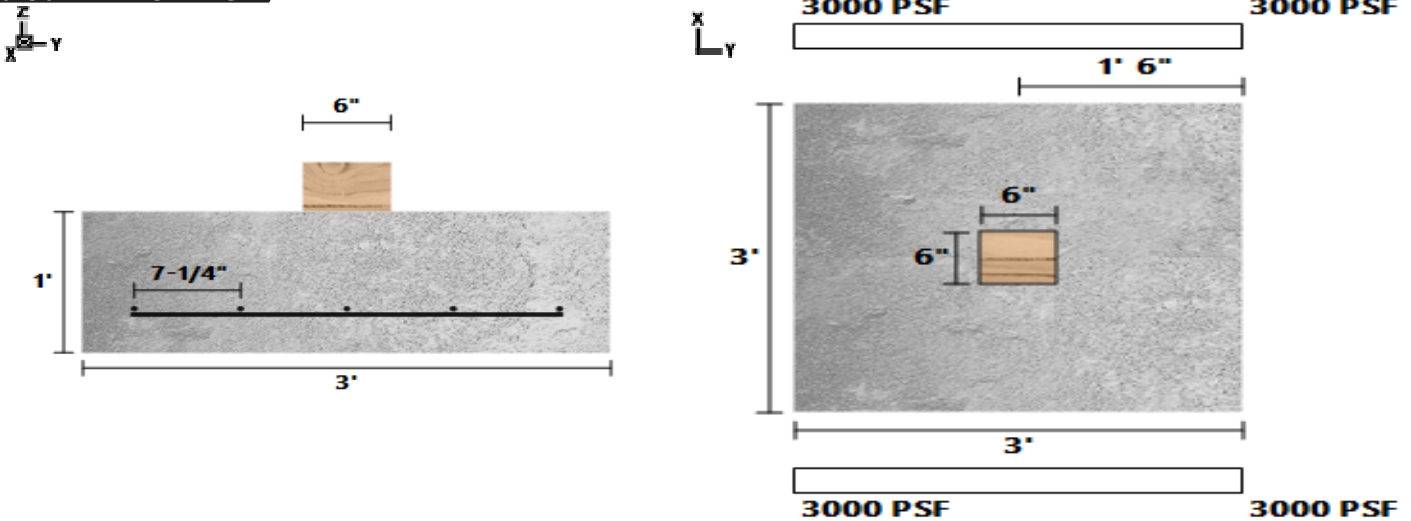

MATERIAL PROPERTIES

FOOTING						
fc' (psi)	Ec (psi)	Density (lbf/ft ³)	Width (ft)	Length (ft)	Depth (in)	Volume (ft ³)
2500	2880952	145	3	3	12	9
CALCULATION VARIABLES						
Bo (in)	Φ-X	Φ-Y				
58	0	0				
COLUMN						
Width (in)	Length (in)	Material	Offset (in)			
6	6	Wood	0			
SOIL						
Bearing Strength (lbf/ft ²)	Density (lbf/ft ³)	Cohesion	Friction Angle	Depth (ft)	Rankine Coefficient (Kp)	
3000	140	0	30	0	3	
REBAR						
Bar Size #	# Bars Long	# Bars Short	fy (psi)	Es (psi)		
4	5	5	40000	2.9E+07		

PASS-FAIL

	PASS/FAIL	MAGNITUDE	STRENGTH	LOAD COMBO
Soil Bearing Pressure (lbf/ft ²)	PASS (0.0%)	3000.0	3000.0	D+L
Two-Way Shear (Punching) (lbf)	PASS (48.6%)	38000.0	73950.0	1.2D+1.6L+0.5Lr
One-Way Shear X (lbf)	PASS (70.1%)	6861.1	22950.0	1.2D+1.6L+0.5Lr
Moment X (lbf-ft)	PASS (60.0%)	9895.8	24715.7	1.2D+1.6L+0.5Lr
One-Way Shear Y (lbf)	PASS (70.1%)	6861.1	22950.0	1.2D+1.6L+0.5Lr
Moment Y (lbf-ft)	PASS (60.0%)	9895.8	24715.7	1.2D+1.6L+0.5Lr
Crushing (psi)	PASS (23.6%)	1055.6	1381.3	1.2D+1.6L+0.5Lr

LOAD LIST

Type	Left Magnitude	Right Magnitude	Load Start (ft)	Load End (ft)	Load Type	Direction
Point (lbf)	13000	-	0	-	Dead	Z
Point (lbf)	14000	-	0	-	Live	Z



Client:		Date:	Jul 29, 2022
Author:	Harrison Kliegl	Job #:	
Project:	3500 PSF Retaining Walls	Subject:	13'-0" Max Retaining Wall PASS
References:	IBC 2021, ASCE 7-16		

| Stability Summary |

Total Sliding Forces	$F_{sliding} = 3.49$ kip/ft	
Total Resistance to Sliding	$F_{resist} = 2.6$ kip/ft	IBC 2018, CI 1806.3
Lateral Force Transmitted to Footing Restraint	$F_{restraint} = 0.891$ kip/ft	
Total Overturning Moment	$M_{overturn} = 16.4$ kip · ft/ft	
Total Restoring Moment	$M_{restore} = 34.3$ kip · ft/ft	
72% Overturning Factor of Safety	$FS_{overturn} = 2.09$	
Maximum Bearing Pressure	$q_{max} = 1210$ psf	
35% Soil Allowable Bearing Capacity	$q_a = 3500$ psf	

| Stem Summary |

Moment Demand of Wall Stem	$M_{u,stem} = 20.3$ kip · ft/ft	
76% Moment Capacity of Wall Stem	$\phi M_{n,stem} = 26.8$ kip · ft/ft	ACI 318-14, CI 22.3
Shear Demand of Wall Stem	$V_{u,stem} = 4.7$ kip/ft	ACI 318-14, CI 9.4.3
64% Shear Capacity of Wall Stem	$\phi V_{n,stem} = 7.37$ kip/ft	ACI 318-14, CI 22.5

| Heel Summary |

Moment Demand of Heel	$M_{u,heel} = 2.43$ kip · ft/ft	ACI 318-14, CI 13.2.7.1
10% Moment Capacity of Heel	$\phi M_{n,heel} = 24.3$ kip · ft/ft	ACI 318-14, CI 22.3
Shear Demand of Heel	$V_{u,heel} = 3.24$ kip/ft	ACI 318-14, CI 9.4.3
33% Shear Capacity of Wall Base	$\phi V_{n,heel} = 9.68$ kip/ft	ACI 318-14, CI 22.5

| Toe Summary |

Moment Demand of Toe	$M_{u,toe} = 22.7$ kip · ft/ft	ACI 318-14, CI 13.2.7.1
93% Moment Capacity of Toe	$\phi M_{n,toe} = 24.3$ kip · ft/ft	ACI 318-14, CI 22.3
Shear Demand of Toe	$V_{u,toe} = 6.28$ kip/ft	ACI 318-14, CI 9.4.3
65% Shear Capacity of Toe	$\phi V_{n,toe} = 9.68$ kip/ft	ACI 318-14, CI 22.5

Key Dimensions

■ Concrete Wall
 ■ Soil Cover
 ■ Backfill

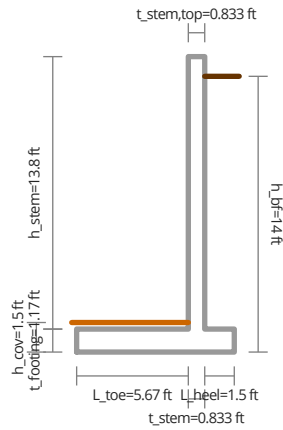

Wall Height	$H = 15 \text{ ft}$
Thickness of Wall Stem at Base	$t_{stem} = 10 \text{ in}$
Thickness of Wall Stem at Top	$t_{stem,top} = 10 \text{ in}$
Length of Toe	$L_{toe} = 5.67 \text{ ft}$
Length of Heel	$L_{heel} = 1.5 \text{ ft}$
Thickness of Footing	$t_{footing} = 14 \text{ in}$

Surcharge

Dead Load Surcharge	$q_D = 0 \text{ psf}$
Dead Load Surcharge is Directly Above Heel?	No
Live Load Surcharge	$q_L = 15 \text{ psf}$

Soil Properties

Height of Backfill	$h_{bf} = 14 \text{ ft}$
Depth of Soil Cover to Bottom of Footing	$h_{cov} = 1.5 \text{ ft}$
Lateral Pressure Method	Equivalent Fluid Pressure - Custom Values <small>IBC 2021</small>
Soil Unit Weight	$\gamma_{input} = 125 \text{ pcf}$
Active Soil Pressure	$p_{a,input} = 35 \text{ psf/ft}$
Allowable Passive / Lateral Bearing Pressure	$p_{p,input} = 300 \text{ psf/ft}$

Base Soil Properties

Source of Soil Properties	Same as Backfill
Allowable Bearing Capacity of Base Soil	$q_{a,input} = 3500 \text{ psf}$
Soil-Footing Friction Coefficient	$\mu_{input} = 0.45$
Base Soil Cohesion	$c_{base,input} = 0 \text{ psf}$
Maximum Allowable Cohesion as Proportion of Dead Load	$c_{max} = 0.5$
Soil-Footing Friction Coefficient	$\mu = 0.45$
Base Soil Cohesion	$c_{base} = 0 \text{ psf}$

If presumptive values are used: IBC 2021 Table 1806.2

If presumptive values are used: IBC 2021 Table 1806.2

Water Table

Height of Water Table

$$h_{water} = 0 \text{ ft}$$

Unit Weight of Water

$$\gamma_{water} = 62.4 \text{ pcf}$$

Concrete Properties

Concrete Strength

$$f'_c = 2500 \text{ psi}$$

ACI 318-14 Table 19.2.1.1

Concrete Weight Classification

Normalweight

ACI 318-14, CI 19.2.4.2

Reinforcement Yield Strength

$$f_y = 60\,000 \text{ psi}$$

ACI 318-14 Table 20.2.2.4a

Stem Reinforcement

Stem Concrete Cover

$$c_{stem} = 1.5 \text{ in}$$

ACI 318-14 Table 20.6.1.3.1

Main Reinforcement Size

#5

Main Reinforcement Spacing

$$s_{stem} = 4.5 \text{ in}$$

ACI 318-14, CI 25.2.1 (minimum spacing) and CI 7.7.2.3 (maximum spacing)

Heel Reinforcement (Top Bars)

Heel Concrete Cover

$$c_{heel} = 3 \text{ in}$$

ACI 318-14 Table 20.6.1.3.1

Heel Reinforcement Size

#4

Heel Reinforcement Spacing

$$s_{heel} = 4.5 \text{ in}$$

ACI 318-14, CI 25.2.1 (minimum spacing) and CI 7.7.2.3 (maximum spacing)

Toe Reinforcement (Bottom Bars)

Include Toe Reinforcement?

Yes

Toe Concrete Cover

$$c_{toe} = 3 \text{ in}$$

ACI 318-14 Table 20.6.1.3.1

Toe Reinforcement Size

#4

Toe Reinforcement Spacing

$$s_{toe} = 4.5 \text{ in}$$

ACI 318-14, CI 25.2.1 (minimum spacing) and CI 7.7.2.3 (maximum spacing)

Shrinkage / Temperature Reinforcement

Shrinkage/Temperature Reinforcement Size

#4

Stem Shrinkage/Temperature Bar Spacing

$$s_{\ell,stem} = 10 \text{ in}$$

ACI 318-14, CI 7.7.2.3

Footing Shrinkage/Temperature Bar Spacing

$$s_{\ell,footing} = 6 \text{ in}$$

ACI 318-14, CI 7.7.2.3

Stem Reinforcement Depth & Spacing

Depth to Stem Reinforcement

$$d_{stem} = 8.19 \text{ in}$$

Area of Vertical Tension Reinforcement

$$A_{s,stem} = 0.827 \text{ in}^2/\text{ft}$$

Heel Reinforcement Depth & Spacing

Heel Depth to Reinforcement

$$d_{heel} = 10.7 \text{ in}$$

ACI 318-14, CI 13.3.1.2

Area of Heel Reinforcement

$$A_{s,heel} = 0.533 \text{ in}^2/\text{ft}$$

Toe Reinforcement Depth & Spacing

Toe Depth to Reinforcement

$$d_{toe} = 10.7 \text{ in}$$

ACI 318-14, CI 13.3.1.2

Area of Toe Reinforcement

$$A_{s,toe} = 0.533 \text{ in}^2/\text{ft}$$

Design Criteria

Design Code for Load Combinations

code = International Building Code (IBC) 2021

Retaining Wall Movement Condition

Active Case (Ka)

Footing Restrained Against Sliding?

Yes

Consider Resisting Soil Pressures for Stability Checks?

No

Consider Soil Above Toe for Stability Checks?	No	
Consider Resisting Pressure from Soil Above Toe for Strength Design?	No	
Sliding Minimum Factor of Safety	$FS_{min,sliding} = 1.5$	IBC 2021, CI 1807.2.3
Overturning Minimum Factor of Safety	$FS_{min,ovt} = 1.5$	IBC 2021, CI 1807.2.3

Unfactored Vertical and Horizontal Loads for Stability Design

Backfill Soil Width	$w_s = 1 \text{ ft}, 6 \text{ in}$	
Weight of Wall Stem	$W_{stem} = 1.73 \text{ kip/ft}$	
Weight of Heel	$W_{heel} = 0.263 \text{ kip/ft}$	
Weight of Toe	$W_{toe} = 0.992 \text{ kip/ft}$	
Weight of Backfill Soil	$W_{bf} = 2.41 \text{ kip/ft}$	
Lateral Force Due to Dead Load Surcharge	$P_D = 0 \text{ kip/ft}$	
Lateral Force Due to Live Load Surcharge	$P_L = 0.0588 \text{ kip/ft}$	
Lateral Force Due to Backfill	$P_{bf} = 3.43 \text{ kip/ft}$	
Passive Force of Soil on Footing	$P_{p,footing} = 0.321 \text{ kip/ft}$	IBC 2021, CI 1806.3.3
Passive Force of Soil Above Toe on Stem	$P_{p,stem} = 0.0167 \text{ kip/ft}$	
Active Force of Soil on Footing	$P_{a,footing} = 0.0374 \text{ kip/ft}$	IBC 2021, CI 1806.3.3
Active Force of Soil Above Toe on Stem	$P_{a,stem} = 0.00194 \text{ kip/ft}$	

Tabulated Soil Loads

Vertical Loads (Resisting)

$\mathbf{W} =$

Element	Unfactored Forces $W_{unfactored}$ (kip/ft)	Load Factor ξ	Weight W (kip/ft)	Moment Arm y (ft)	Restoring Moment $M_{restore}$ (kip · ft/ft)
Dead Load Surcharge	0	1	0	7.25	0
Wall Stem	1.73	1	1.73	6.09	10.5
Wall Footing	1.4	1	1.4	4	5.6
Soil Cover Above Toe	0.236	1	0.236	2.84	0.67
Backfill Above Water Table	2.41	1	2.41	7.25	17.5

Live Load Surcharge Vertical Loads (Soil Bearing)

$\mathbf{W}_L =$

Element	Unfactored Forces $W_{unfactored}$ (kip/ft)	Load Factor ξ	Weight W (kip/ft)	Moment Arm y (ft)	Restoring Moment $M_{restore}$ (kip · ft/ft)
Live Load Surcharge	0.0225	1	0.0225	7.25	0.163

Lateral Loads

$\mathbf{H} =$

IBC 2018, CI 1605.2

Element	Unfactored Forces $H_{unfactored}$ (kip/ft)	Load Factor ξ	Lateral Load H (kip/ft)	Moment Arm y (ft)	Overturning Moment $M_{overturn}$ (kip · ft/ft)
Dead Load Surcharge	0	1	0	7	0
Live Load Surcharge	0.0588	1	0.0588	7	0.412
Backfill	3.43	1	3.43	4.67	16

Passive Soil Loads (Resisting Sliding)

$\mathbf{F}_p =$

Element	Unfactored Passive Forces $F_{p,unfactored}$ (kip/ft)	Load Factor ξ	Passive Lateral Resisting Load F_p (kip/ft)
Soil Against Toe Face	0.321	0.6	0.193

Active Soil Loads (Resisting Overturning)

$\mathbf{F}_a =$

Element	Unfactored Active Forces $F_{a,unfactored}$ (kip/ft)	Load Factor ξ	Active Lateral Resisting Load F_a (kip/ft)	Moment Arm y (ft)	Active Resisting Moment M_a (kip · ft/ft)
Soil Against Toe Face	0.0374	0.6	0.0225	0.46	0.0103

Stability Analysis - Sliding Loads

Total Horizontal Loads (Sliding)

$H_{total} = 3.49 \text{ kip/ft}$

Total Vertical Loads (Resisting) $W_{total} = 5.77$ kip/ft
 Total Passive Loads (Resisting) $F_{p,total} = 0.193$ kip/ft

Stability Analysis - Overturning Loads

Total Overturning Moment $M_{over} = 16.4$ kip · ft/ft
 Total Restoring Moment from Gravity $M_{res,grav} = 34.3$ kip · ft/ft

Stability Analysis - Soil Bearing Check

Eccentricity (Live Load Not Over Heel) $e = 0$ ft, 10.9 in
 Eccentricity (Live Load Over Heel) $e_L = 0$ ft, 10.7 in
 Bearing Pressures **BP** =

IBC 2021, CI 1605.2

Location	Live Load Not Over Heel q (psf)	Live Load Over Heel q_L (psf)
Toe	1210	1210
At d from stem face	626	630
Stem face	516	521
Heel	228	238

Unfactored Vertical Loads for Structural Strength Design

Lateral Force on Stem Due to Dead Load Surcharge $P_{D,stem} = 0$ kip/ft
 Lateral Force on Stem Due to Live Load Surcharge $P_{L,stem} = 0.0539$ kip/ft
 Lateral Force on Stem Due to Backfill $P_{bf,stem} = 2.88$ kip/ft

Structural Strength Design Loads

Lateral Stem Loads

SL =

IBC 2021, CI 1605.2

Element	Unfactored Forces H (kip/ft)	Load Factor ξ	Factored Horizontal Loads H_u (kip/ft)	Moment Arm y (ft)	Stem Moment $M_{u,stem}$ (kip · ft/ft)
Dead Load Surcharge	0	1.6	0	6.42	0
Live Load Surcharge	0.0539	1.6	0.0862	6.42	0.553
Backfill	2.88	1.6	4.61	4.28	19.7

Heel Loads

HL =

Element	Unfactored Forces W (kip/ft)	Load Factor ξ	Factored Weight W_u (kip/ft)	Moment Arm y (ft)	Heel Moment $M_{u,heel}$ (kip · ft/ft)
Dead Load Surcharge	0	1.2	0	0.75	0
Live Load Surcharge	0.0225	1.6	0.036	0.75	0.027
Heel Weight	0.263	1.2	0.315	0.75	0.236
Backfill Above Water Table	2.41	1.2	2.89	0.75	2.17

Toe Loads (Shear)

TL_V =

Element	Unfactored Shear Load at d V_d (kip/ft)	Load Factor ξ	Factored Shear Load V_u (kip/ft)
Upwards Soil Pressure	4.39	1.6	7.03
Toe Weight	-0.835	0.9	-0.752

Toe Loads (Moment)

TL_M =

Element	Unfactored Toe Loads P (kip/ft)	Load Factor ξ	Moment Arm y (ft)	Toe Moment M_u (kip · ft/ft)
Upwards Soil Pressure	4.9	1.6	3.21	25.2
Toe Weight	-0.992	0.9	2.84	-2.53

Stem Flexural Analysis (ACI 318-14, CI 22.2)

Tension Reinforcement Strain

$\epsilon_t = 0.00773$

ACI 318-14, CI 22.2.2.4.1 and CI 7.3.3.1 for strain limit

Resistance Factor in Bending

$$\phi_b = 0.9$$

ACI 318-14, Table 21.2.2

Factored Moment Capacity

$$\phi M_n = 26\,800 \text{ lb} \cdot \text{ft}/\text{ft}$$

ACI 318-14, 8.5.1.1a

Heel Flexural Analysis (ACI 318-14, CI 22.2)

Tension Reinforcement Strain

$$\epsilon_t = 0.0188$$

ACI 318-14, CI 22.2.2.4.1 and CI 7.3.3.1 for strain limit

Resistance Factor in Bending

$$\phi_b = 0.9$$

ACI 318-14, Table 21.2.2

Factored Moment Capacity

$$\phi M_{n,heel} = 24\,300 \text{ lb} \cdot \text{ft}/\text{ft}$$

ACI 318-14, 8.5.1.1a

Toe Flexural Analysis (ACI 318-14, CI 22.2)

Tension Reinforcement Strain

$$\epsilon_t = 0.0188$$

ACI 318-14, CI 22.2.2.4.1 and CI 7.3.3.1 for strain limit

Resistance Factor in Bending

$$\phi_b = 0.9$$

ACI 318-14, Table 21.2.1

Factored Moment Capacity

$$\phi M_{n,toe} = 24\,300 \text{ lb} \cdot \text{ft}/\text{ft}$$

ACI 318-14, 8.5.1.1a

Shear in Stem (ACI 318-14, CI 22.5)

Resistance Factor in Shear

$$\phi_v = 0.75$$

ACI 318-14 Table 21.2.1

Factored Stem Shear Capacity

$$\phi V_{n,stem} = 7370 \text{ plf}$$

ACI 318-14, CI 22.5.5

Shear in Heel (ACI 318-14, CI 22.5)

Factored Base Shear Capacity

$$\phi V_{n,base} = 9670 \text{ plf}$$

ACI 318-14, CI 22.5.5

Shear in Toe (ACI 318-14, CI 22.5)

Resistance Factor in Shear (Toe)

$$\phi_{v,toe} = 0.75$$

ACI 318-14 Table 21.2.1

Factored Toe Shear Capacity

$$\phi V_{n,toe} = 9670 \text{ plf}$$

ACI 318-14, CI 22.5.5

Comments



LONGITUDE
ONE TWENTY°
ENGINEERING & DESIGN

Supplementary Calculations for the following:

- ~ ***Hold-down anchor design/calculations***
- ~ ***Hand-rail calculations (wood/concrete)***
- ~ ***Balloon framed stud design***

- ~ ***Ledger Calculations/Data***



Hold-down anchor design calculations



Company:	L120 Engineering & Design	Date:	5/3/2018
Engineer:	MRT	Page:	1/4
Project:	Hold-down Anchors		
Address:			
Phone:			
E-mail:			

1. Project information

Customer company:
 Customer contact name:
 Customer e-mail:
 Comment:

Project description:
 Location:
 Fastening description:

5/8" DIA Anchor

2. Input Data & Anchor Parameters

General

Design method: ACI 318-14
 Units: Imperial units

Anchor Information:

Anchor type: Cast-in-place
 Material: AB_H
 Diameter (inch): 0.625
 Effective Embedment depth, h_{ef} (inch): 4.000
 Anchor category: -
 Anchor ductility: Yes
 h_{min} (inch): 6.13
 C_{min} (inch): 1.38
 S_{min} (inch): 2.50

Base Material

Concrete: Normal-weight
 Concrete thickness, h (inch): 18.00
 State: Cracked
 Compressive strength, f_c (psi): 2500
 $\Psi_{c,v}$: 1.0
 Reinforcement condition: A tension, A shear
 Supplemental reinforcement: Not applicable
 Reinforcement provided at corners: Yes
 Ignore concrete breakout in tension: No
 Ignore concrete breakout in shear: No
 Ignore 6do requirement: Yes
 Build-up grout pad: No

Load and Geometry

Load factor source: ACI 318 Section 5.3
 Load combination: $U = 0.9D + 1.0E$
 Seismic design: Yes
 Anchors subjected to sustained tension: Not applicable
 Ductility section for tension: 17.2.3.4.3 (a) (iii)-(vi) is satisfied
 Ductility section for shear: 17.2.3.5.2 not applicable
 Ω_0 factor: not set
 Apply entire shear load at front row: No
 Anchors only resisting wind and/or seismic loads: Yes

<Figure 1>

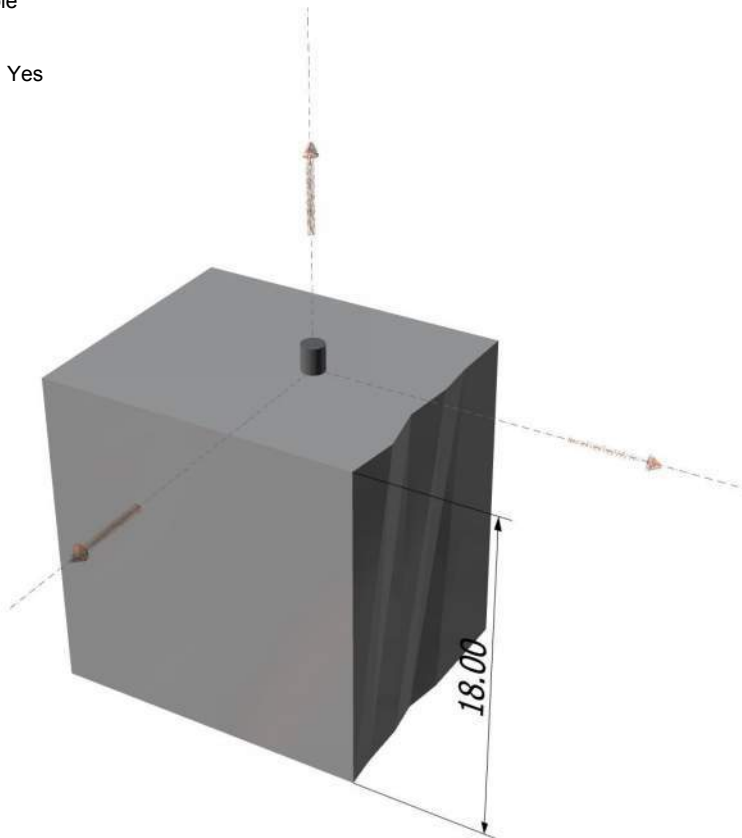

Input data and results must be checked for agreement with the existing circumstances, the standards and guidelines must be checked for plausibility.



Company:	L120 Engineering & Design	Date:	5/3/2018
Engineer:	MRT	Page:	2/4
Project:	Hold-down Anchors		
Address:			
Phone:			
E-mail:			

<Figure 2>

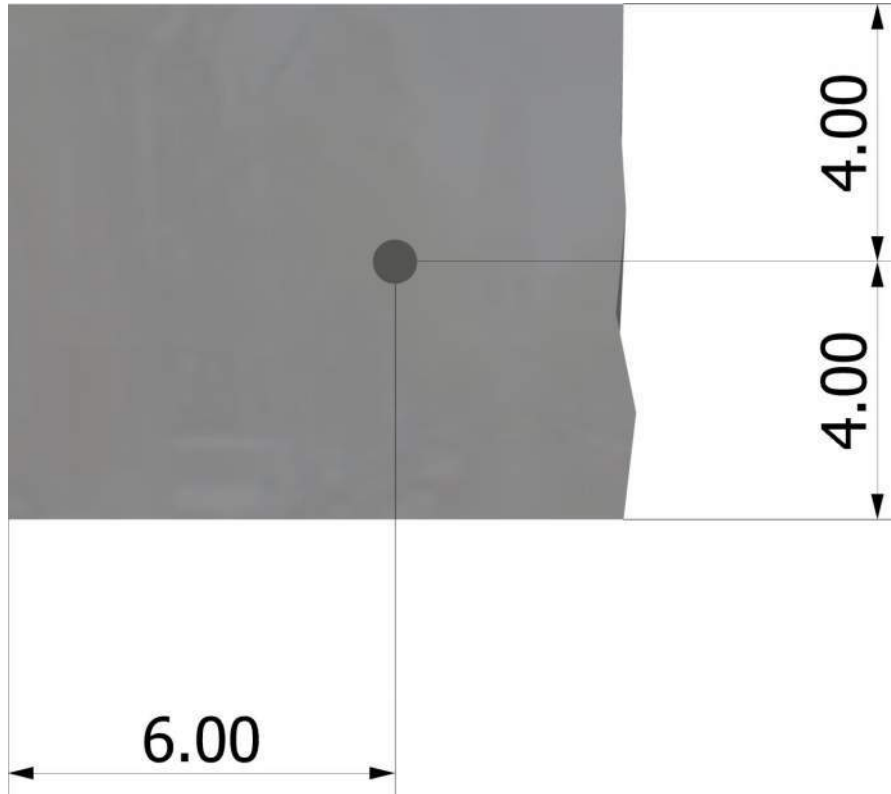

Recommended Anchor

Anchor Name: PAB Pre-Assembled Anchor Bolt - PAB5H (5/8"Ø)





Anchor Designer™
Software
Version 2.5.6582.0

Company:	L120 Engineering & Design	Date:	5/3/2018
Engineer:	MRT	Page:	3/4
Project:	Hold-down Anchors		
Address:			
Phone:			
E-mail:			

3. Resulting Anchor Forces

Anchor	Tension load, N _{ua} (lb)	Shear load x, V _{uax} (lb)	Shear load y, V _{uay} (lb)	Shear load combined, $\sqrt{(V_{uax})^2 + (V_{uay})^2}$ (lb)
1	2925.0	0.0	0.0	0.0
Sum	2925.0	0.0	0.0	0.0

Maximum concrete compression strain (%): 0.00
 Maximum concrete compression stress (psi): 0
 Resultant tension force (lb): 2925
 Resultant compression force (lb): 0
 Eccentricity of resultant tension forces in x-axis, e'_{Nx} (inch): 0.00
 Eccentricity of resultant tension forces in y-axis, e'_{Ny} (inch): 0.00

4. Steel Strength of Anchor in Tension (Sec. 17.4.1)

N _{sa} (lb)	φ	φN _{sa} (lb)
27120	0.75	20340

5. Concrete Breakout Strength of Anchor in Tension (Sec. 17.4.2)

$$N_b = k_c \lambda_a \sqrt{f_c} h_{ef}^{1.5} \text{ (Eq. 17.4.2.2a)}$$

k _c	λ _a	f _c (psi)	h _{ef} (in)	N _b (lb)
24.0	1.00	2500	4.000	9600

$$0.75 \phi N_{cb} = 0.75 \phi (A_{Nc} / A_{Nco}) \Psi_{ed,N} \Psi_{c,N} \Psi_{cp,N} N_b \text{ (Sec. 17.3.1 \& Eq. 17.4.2.1a)}$$

A _{Nc} (in ²)	A _{Nco} (in ²)	c _{a,min} (in)	Ψ _{ed,N}	Ψ _{c,N}	Ψ _{cp,N}	N _b (lb)	φ	0.75 φN _{cb} (lb)
103.00	144.00	4.00	0.900	1.00	1.000	9600	0.75	3476

6. Pullout Strength of Anchor in Tension (Sec. 17.4.3)

$$0.75 \phi N_{pn} = 0.75 \phi \Psi_{c,P} N_p = 0.75 \phi \Psi_{c,P} 8 A_{brg} f_c \text{ (Sec. 17.3.1, Eq. 17.4.3.1 \& 17.4.3.4)}$$

Ψ _{c,P}	A _{brg} (in ²)	f _c (psi)	φ	0.75 φN _{pn} (lb)
1.0	2.10	2500	0.70	22029

Input data and results must be checked for agreement with the existing circumstances, the standards and guidelines must be checked for plausibility.



Company:	L120 Engineering & Design	Date:	5/3/2018
Engineer:	MRT	Page:	4/4
Project:	Hold-down Anchors		
Address:			
Phone:			
E-mail:			

11. Results

11. Interaction of Tensile and Shear Forces (Sec. D.7)?

Tension	Factored Load, N_{ua} (lb)	Design Strength, ϕN_n (lb)	Ratio	Status
Steel	2925	20340	0.14	Pass
Concrete breakout	2925	3476	0.84	Pass (Governs)
Pullout	2925	22029	0.13	Pass

PAB5H (5/8"Ø) with hef = 4.000 inch meets the selected design criteria.

ACI 318-14 Section 17.2.3.4.3(a) (i) & (ii) Calculations for Ductility requirement for tension load

Steel	Factored Load, N_{ua} (lb)	1.2 x Nominal Strength, N_n (lb)	Ratio	
Steel	2925	32544	9.0 %	
Concrete	Nominal Strength, N_n (lb)	Nominal Strength, N_n (lb)	Ratio	
Concrete breakout	2925	6180	47.3 %	Governs
Pullout	2925	41960	7.0 %	

ACI 318-14 Section 17.2.3.4.3(a) (i) & (ii) is not satisfied since steel ratio does not govern.

12. Warnings

- Minimum spacing and edge distance requirement of 6da per ACI 318 Sections 17.7.1 and 17.7.2 for torqued cast-in-place anchor is waived per designer option.

- Brittle failure governs for tension. Governing anchor failure mode is brittle failure. Attachment shall be designed to satisfy the requirements of ACI 318-14 Section 17.2.3.4.3 for structures assigned to Seismic Design Category C, D, E, or F when the component of the strength level earthquake force applied to anchors exceeds 20 percent of the total factored anchor force associated with the same load combination. In case when ACI 318-14 Sections 17.2.3.4.3 (a)(iii) to (vi), (b), (c) or (d) is satisfied for tension loading, select appropriate checkbox from Inputs tab to disable this message. Alternatively, Ω_0 factor can be entered to satisfy ACI 318-14 Section 17.2.3.4.3(d) to increase the earthquake portion of the loads as required.

- Per designer input, the shear component of the strength-level earthquake force applied to anchors does not exceed 20 percent of the total factored anchor shear force associated with the same load combination. Therefore the ductility requirements of ACI 318 17.2.3.5.2 for shear need not be satisfied – designer to verify.

- Designer must exercise own judgement to determine if this design is suitable.



Company:	L120 Engineering & Design	Date:	1/14/2018
Engineer:	MRT	Page:	1/4
Project:	Hold-down Anchors		
Address:			
Phone:			
E-mail:			

1. Project information

Customer company:
Customer contact name:
Customer e-mail:
Comment:

Project description:
Location:
Fastening description:

3/4" DIA Anchor

2. Input Data & Anchor Parameters

General

Design method: ACI 318-14
Units: Imperial units

Anchor Information:

Anchor type: Cast-in-place
Material: AB
Diameter (inch): 0.750
Effective Embedment depth, h_{ef} (inch): 12.000
Anchor category: -
Anchor ductility: Yes
 h_{min} (inch): 14.25
 C_{min} (inch): 1.63
 S_{min} (inch): 3.00

Base Material

Concrete: Normal-weight
Concrete thickness, h (inch): 18.00
State: Cracked
Compressive strength, f_c (psi): 2500
 $\Psi_{c,v}$: 1.0
Reinforcement condition: A tension, A shear
Supplemental reinforcement: Not applicable
Reinforcement provided at corners: Yes
Ignore concrete breakout in tension: Yes
Ignore concrete breakout in shear: No
Ignore 6do requirement: Yes
Build-up grout pad: No

Load and Geometry

Load factor source: ACI 318 Section 5.3
Load combination: $U = 0.9D + 1.0E$
Seismic design: Yes
Anchors subjected to sustained tension: Not applicable
Ductility section for tension: 17.2.3.4.3 (a) (iii)-(vi) is satisfied
Ductility section for shear: 17.2.3.5.2 not applicable
 Ω_D factor: not set
Apply entire shear load at front row: No
Anchors only resisting wind and/or seismic loads: Yes

<Figure 1>

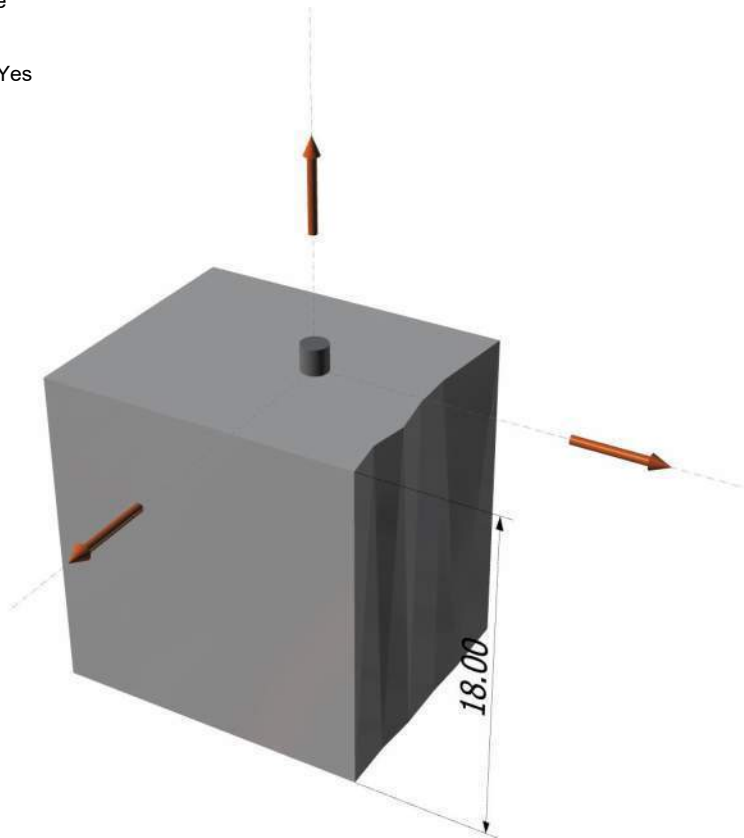



Company:	L120 Engineering & Design	Date:	1/14/2018
Engineer:	MRT	Page:	2/4
Project:	Hold-down Anchors		
Address:			
Phone:			
E-mail:			

<Figure 2>

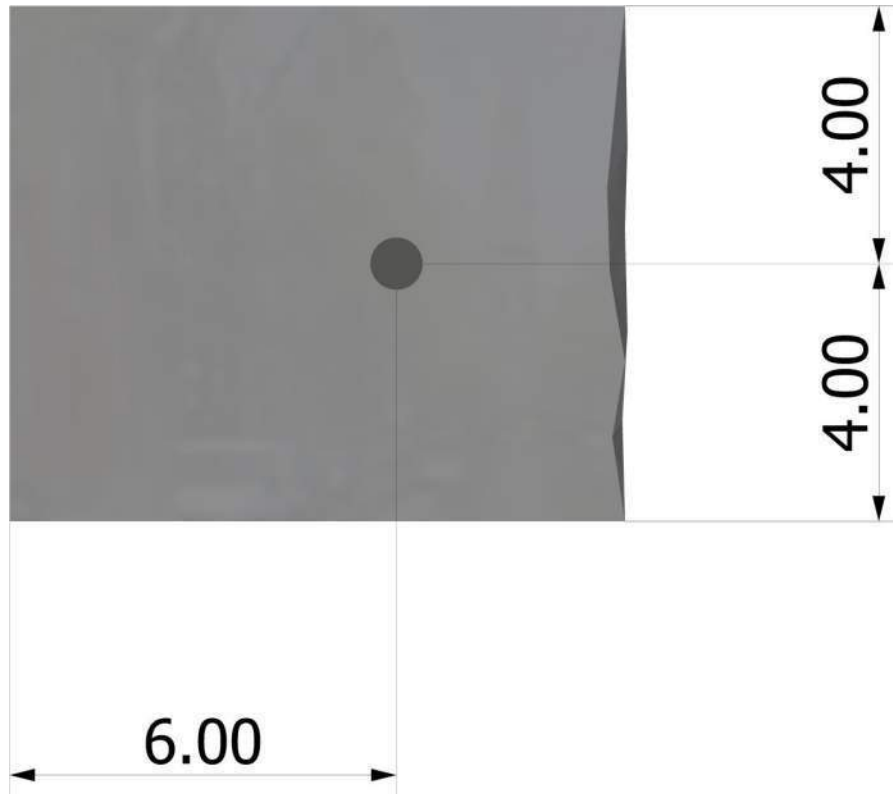

Recommended Anchor

Anchor Name: PAB Pre-Assembled Anchor Bolt - PAB6 (3/4"Ø)





Anchor Designer™
Software
Version 2.5.6582.0

Company:	L120 Engineering & Design	Date:	1/14/2018
Engineer:	MRT	Page:	3/4
Project:	Hold-down Anchors		
Address:			
Phone:			
E-mail:			

3. Resulting Anchor Forces

Anchor	Tension load, N_{ua} (lb)	Shear load x, V_{uax} (lb)	Shear load y, V_{uay} (lb)	Shear load combined, $\sqrt{(V_{uax})^2 + (V_{uay})^2}$ (lb)
1	13050.0	0.0	0.0	0.0
Sum	13050.0	0.0	0.0	0.0

Maximum concrete compression strain (%): 0.00
 Maximum concrete compression stress (psi): 0
 Resultant tension force (lb): 0
 Resultant compression force (lb): 0
 Eccentricity of resultant tension forces in x-axis, e'_{Nx} (inch): 0.00
 Eccentricity of resultant tension forces in y-axis, e'_{Ny} (inch): 0.00

4. Steel Strength of Anchor in Tension (Sec. 17.4.1)

N_{sa} (lb)	ϕ	ϕN_{sa} (lb)
19370	0.75	14528

6. Pullout Strength of Anchor in Tension (Sec. 17.4.3)

$0.75\phi N_{pn} = 0.75\phi\psi_{c,P}N_p = 0.75\phi\psi_{c,P}8A_{brg}f_c$ (Sec. 17.3.1, Eq. 17.4.3.1 & 17.4.3.4)

$\psi_{c,P}$	A_{brg} (in ²)	f_c (psi)	ϕ	$0.75\phi N_{pn}$ (lb)
1.0	3.53	2500	0.70	37107

Input data and results must be checked for agreement with the existing circumstances, the standards and guidelines must be checked for plausibility.



Company:	L120 Engineering & Design	Date:	1/14/2018
Engineer:	MRT	Page:	4/4
Project:	Hold-down Anchors		
Address:			
Phone:			
E-mail:			

7. Side-Face Blowout Strength of Anchor in Tension (Sec. 17.4.4)

$$0.75\phi N_{sb} = 0.75\phi \left\{ (1 + c_{a2}/c_{a1})/4 \right\} (160c_{a1}\sqrt{A_{brg}})\lambda\sqrt{f'_c} \text{ (Sec. 17.3.1 \& Eq. 17.4.4.1)}$$

c_{a1} (in)	c_{a2} (in)	A_{brg} (in ²)	λ_a	f'_c (psi)	ϕ	$0.75\phi N_{sbg}$ (lb)
4.00	6.00	3.53	1.00	2500	0.75	21149

11. Results

11. Interaction of Tensile and Shear Forces (Sec. D.7)?

Tension	Factored Load, N_{ua} (lb)	Design Strength, ϕN_n (lb)	Ratio	Status
Steel	13050	14528	0.90	Pass (Governs)
Pullout	13050	37107	0.35	Pass
Side-face blowout	13050	21149	0.62	Pass

PAB6 (3/4"Ø) with hef = 12.000 inch meets the selected design criteria.

ACI 318-14 Section 17.2.3.4.3(a) (i) & (ii) Calculations for Ductility requirement for tension load

Steel	Factored Load, N_{ua} (lb)	1.2 x Nominal Strength, N_n (lb)	Ratio	
Steel	13050	23244	56.1%	Governs

Concrete	Nominal Strength, N_n (lb)	Nominal Strength, N_n (lb)	Ratio	
Pullout	13050	70680	18.5%	
Side-face blowout	13050	37598	34.7%	

ACI 318-14 Section 17.2.3.4.3(a) (i) & (ii) satisfied since steel ratio governs and the steel element is ductile.

12. Warnings

- Minimum spacing and edge distance requirement of $6d_a$ per ACI 318 Sections 17.7.1 and 17.7.2 for torqued cast-in-place anchor is waived per designer option.
- Concrete breakout strength in tension has not been evaluated against applied tension load(s) per designer option. Refer to ACI 318 Section 17.3.2.1 for conditions where calculations of the concrete breakout strength may not be required.
- Per designer input, the shear component of the strength-level earthquake force applied to anchors does not exceed 20 percent of the total factored anchor shear force associated with the same load combination. Therefore the ductility requirements of ACI 318 17.2.3.5.2 for shear need not be satisfied – designer to verify.
- Designer must exercise own judgement to determine if this design is suitable.



Company:	L120 Engineering & Design	Date:	1/14/2018
Engineer:	MRT	Page:	1/5
Project:	Hold-down Anchors		
Address:			
Phone:			
E-mail:			

1. Project information

Customer company:
 Customer contact name:
 Customer e-mail:
 Comment:

Project description:
 Location:
 Fastening description:

7/8" DIA Anchor

2. Input Data & Anchor Parameters

General

Design method: ACI 318-14
 Units: Imperial units

Anchor Information:

Anchor type: Cast-in-place
 Material: AB_H
 Diameter (inch): 0.875
 Effective Embedment depth, h_{ef} (inch): 12.000
 Anchor category: -
 Anchor ductility: Yes
 h_{min} (inch): 14.38
 C_{min} (inch): 1.75
 S_{min} (inch): 3.50

Base Material

Concrete: Normal-weight
 Concrete thickness, h (inch): 18.00
 State: Cracked
 Compressive strength, f_c (psi): 2500
 $\Psi_{c,v}$: 1.0
 Reinforcement condition: A tension, A shear
 Supplemental reinforcement: Not applicable
 Reinforcement provided at corners: Yes
 Ignore concrete breakout in tension: Yes
 Ignore concrete breakout in shear: No
 Ignore 6do requirement: Yes
 Build-up grout pad: No

Load and Geometry

Load factor source: ACI 318 Section 5.3
 Load combination: $U = 0.9D + 1.0E$
 Seismic design: Yes
 Anchors subjected to sustained tension: Not applicable
 Ductility section for tension: 17.2.3.4.3 (a) (iii)-(vi) is satisfied
 Ductility section for shear: 17.2.3.5.2 not applicable
 Ω_0 factor: not set
 Apply entire shear load at front row: No
 Anchors only resisting wind and/or seismic loads: Yes

<Figure 1>

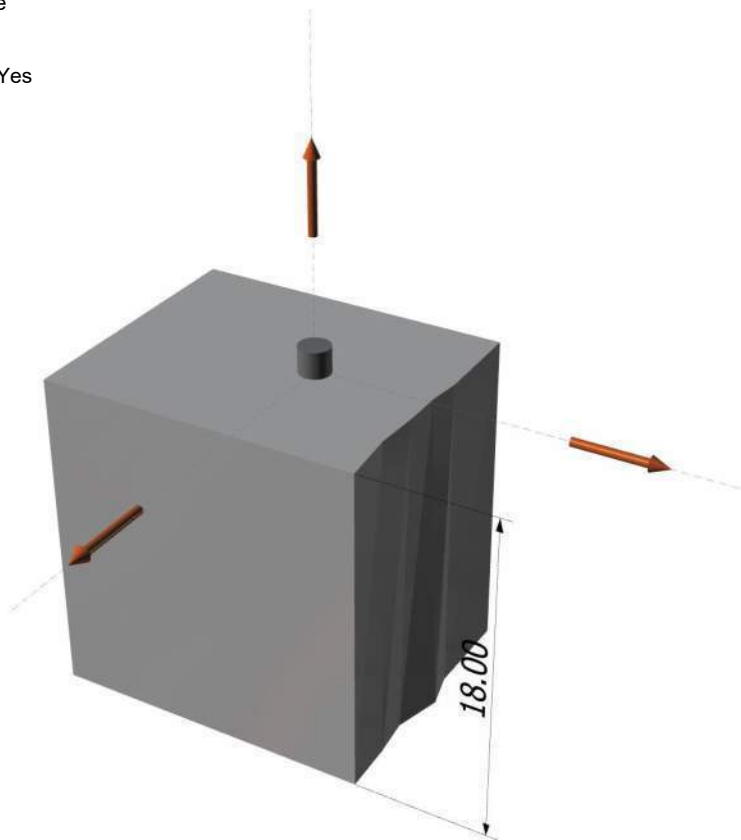



Company:	L120 Engineering & Design	Date:	1/14/2018
Engineer:	MRT	Page:	2/5
Project:	Hold-down Anchors		
Address:			
Phone:			
E-mail:			

<Figure 2>

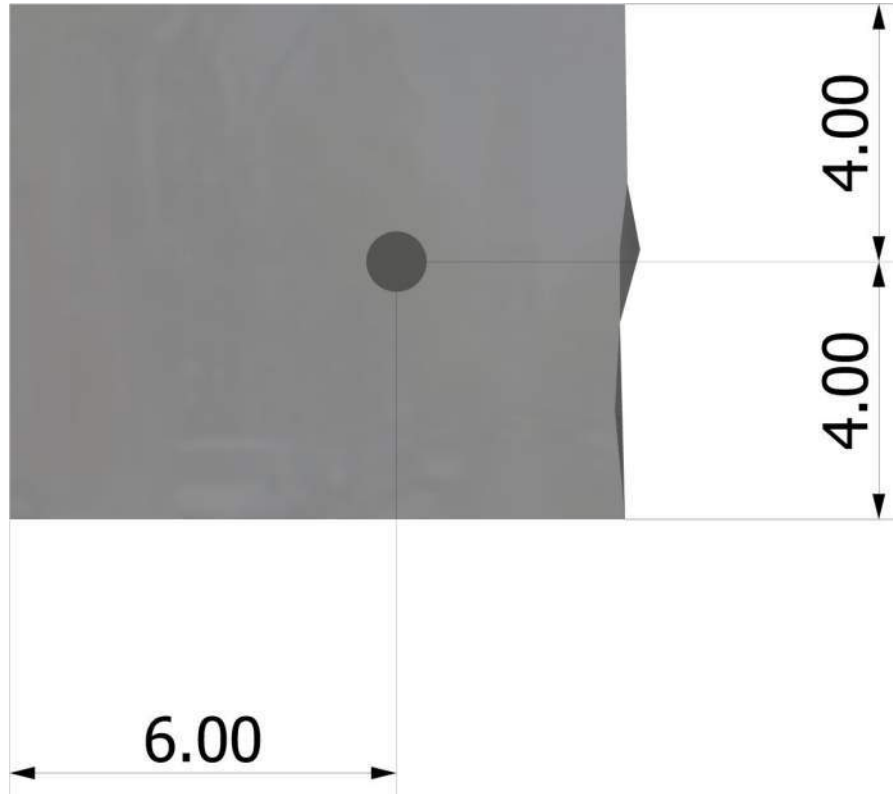

Recommended Anchor

Anchor Name: PAB Pre-Assembled Anchor Bolt - PAB7H (7/8"Ø)





Company:	L120 Engineering & Design	Date:	1/14/2018
Engineer:	MRT	Page:	3/5
Project:	Hold-down Anchors		
Address:			
Phone:			
E-mail:			

3. Resulting Anchor Forces

Anchor	Tension load, N_{ua} (lb)	Shear load x, V_{uax} (lb)	Shear load y, V_{uay} (lb)	Shear load combined, $\sqrt{(V_{uax})^2 + (V_{uay})^2}$ (lb)
1	18000.0	0.0	0.0	0.0
Sum	18000.0	0.0	0.0	0.0

Maximum concrete compression strain (%): 0.00
 Maximum concrete compression stress (psi): 0
 Resultant tension force (lb): 0
 Resultant compression force (lb): 0
 Eccentricity of resultant tension forces in x-axis, e'_{Nx} (inch): 0.00
 Eccentricity of resultant tension forces in y-axis, e'_{Ny} (inch): 0.00

4. Steel Strength of Anchor in Tension (Sec. 17.4.1)

N_{sa} (lb)	ϕ	ϕN_{sa} (lb)
55440	0.75	41580

6. Pullout Strength of Anchor in Tension (Sec. 17.4.3)

$0.75\phi N_{pn} = 0.75\phi\psi_{c,P}N_p = 0.75\phi\psi_{c,P}8A_{brg}f_c$ (Sec. 17.3.1, Eq. 17.4.3.1 & 17.4.3.4)

$\psi_{c,P}$	A_{brg} (in ²)	f_c (psi)	ϕ	$0.75\phi N_{pn}$ (lb)
1.0	4.07	2500	0.70	42683



Company:	L120 Engineering & Design	Date:	1/14/2018
Engineer:	MRT	Page:	4/5
Project:	Hold-down Anchors		
Address:			
Phone:			
E-mail:			

7. Side-Face Blowout Strength of Anchor in Tension (Sec. 17.4.4)

$$0.75\phi N_{sb} = 0.75\phi \left\{ (1 + c_{a2}/c_{a1})/4 \right\} (160c_{a1}\sqrt{A_{brg}})\lambda\sqrt{f'_c} \text{ (Sec. 17.3.1 \& Eq. 17.4.4.1)}$$

c_{a1} (in)	c_{a2} (in)	A_{brg} (in ²)	λ_a	f'_c (psi)	ϕ	$0.75\phi N_{sb}$ (lb)
4.00	6.00	4.07	1.00	2500	0.75	22682

11. Results

11. Interaction of Tensile and Shear Forces (Sec. D.7)?

Tension	Factored Load, N_{ua} (lb)	Design Strength, ϕN_n (lb)	Ratio	Status
Steel	18000	41580	0.43	Pass
Pullout	18000	42683	0.42	Pass
Side-face blowout	18000	22682	0.79	Pass (Governs)

PAB7H (7/8"Ø) with hef = 12.000 inch meets the selected design criteria.

ACI 318-14 Section 17.2.3.4.3(a) (i) & (ii) Calculations for Ductility requirement for tension load

Steel	Factored Load, N_{ua} (lb)	1.2 x Nominal Strength, N_n (lb)	Ratio	
Steel	18000	66528	27.1%	
Concrete	Nominal Strength, N_n (lb)	Nominal Strength, N_n (lb)	Ratio	
Pullout	18000	81300	22.1%	
Side-face blowout	18000	40324	44.6%	Governs

ACI 318-14 Section 17.2.3.4.3(a) (i) & (ii) is not satisfied since steel ratio does not govern.



Company:	L120 Engineering & Design	Date:	1/14/2018
Engineer:	MRT	Page:	5/5
Project:	Hold-down Anchors		
Address:			
Phone:			
E-mail:			

12. Warnings

- Minimum spacing and edge distance requirement of 6da per ACI 318 Sections 17.7.1 and 17.7.2 for torqued cast-in-place anchor is waived per designer option.
- Concrete breakout strength in tension has not been evaluated against applied tension load(s) per designer option. Refer to ACI 318 Section 17.3.2.1 for conditions where calculations of the concrete breakout strength may not be required.
- Brittle failure governs for tension. Governing anchor failure mode is brittle failure. Attachment shall be designed to satisfy the requirements of ACI 318-14 Section 17.2.3.4.3 for structures assigned to Seismic Design Category C, D, E, or F when the component of the strength level earthquake force applied to anchors exceeds 20 percent of the total factored anchor force associated with the same load combination. In case when ACI 318-14 Sections 17.2.3.4.3 (a)(iii) to (vi), (b), (c) or (d) is satisfied for tension loading, select appropriate checkbox from Inputs tab to disable this message. Alternatively, Ω_0 factor can be entered to satisfy ACI 318-14 Section 17.2.3.4.3(d) to increase the earthquake portion of the loads as required.
- Per designer input, the shear component of the strength-level earthquake force applied to anchors does not exceed 20 percent of the total factored anchor shear force associated with the same load combination. Therefore the ductility requirements of ACI 318 17.2.3.5.2 for shear need not be satisfied – designer to verify.
- Designer must exercise own judgement to determine if this design is suitable.



Company:	L120 Engineering & Design	Date:	1/14/2018
Engineer:	MRT	Page:	1/5
Project:	Hold-down Anchors		
Address:			
Phone:			
E-mail:			

1. Project information

Customer company:
Customer contact name:
Customer e-mail:
Comment:

Project description:
Location:
Fastening description:

1" DIA Anchor

2. Input Data & Anchor Parameters

General

Design method: ACI 318-14
Units: Imperial units

Anchor Information:

Anchor type: Cast-in-place
Material: AB_H
Diameter (inch): 1.000
Effective Embedment depth, h_{ef} (inch): 15.000
Anchor category: -
Anchor ductility: Yes
 h_{min} (inch): 17.63
 C_{min} (inch): 1.88
 S_{min} (inch): 4.00

Base Material

Concrete: Normal-weight
Concrete thickness, h (inch): 18.00
State: Cracked
Compressive strength, f_c (psi): 2500
 $\Psi_{c,v}$: 1.0
Reinforcement condition: A tension, A shear
Supplemental reinforcement: Not applicable
Reinforcement provided at corners: Yes
Ignore concrete breakout in tension: Yes
Ignore concrete breakout in shear: No
Ignore 6do requirement: Yes
Build-up grout pad: No

Load and Geometry

Load factor source: ACI 318 Section 5.3
Load combination: $U = 0.9D + 1.0E$
Seismic design: Yes
Anchors subjected to sustained tension: Not applicable
Ductility section for tension: 17.2.3.4.3 (a) (iii)-(vi) is satisfied
Ductility section for shear: 17.2.3.5.2 not applicable
 Ω_D factor: not set
Apply entire shear load at front row: No
Anchors only resisting wind and/or seismic loads: Yes

<Figure 1>

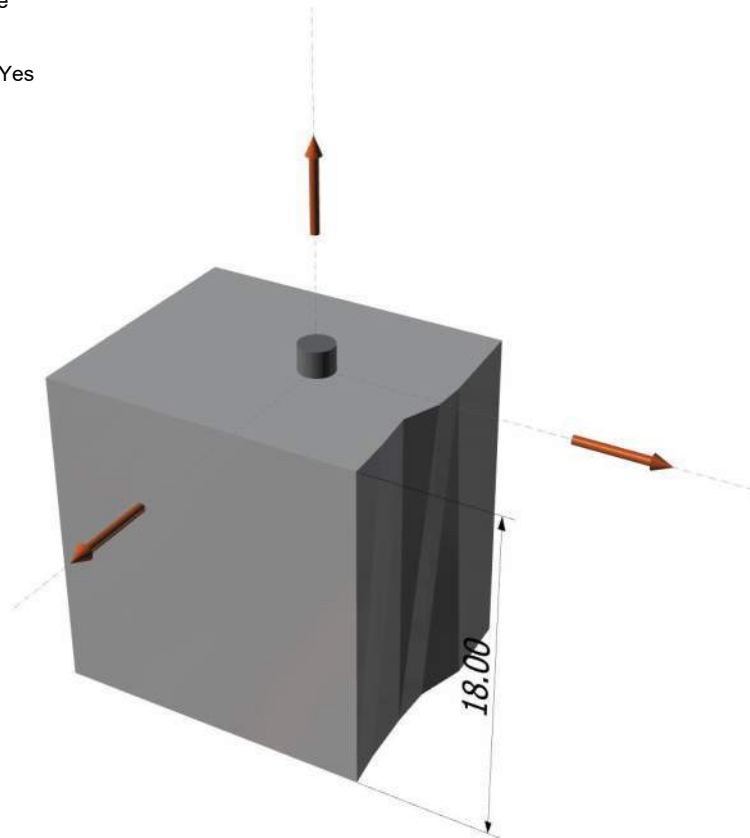



Company:	L120 Engineering & Design	Date:	1/14/2018
Engineer:	MRT	Page:	2/5
Project:	Hold-down Anchors		
Address:			
Phone:			
E-mail:			

<Figure 2>

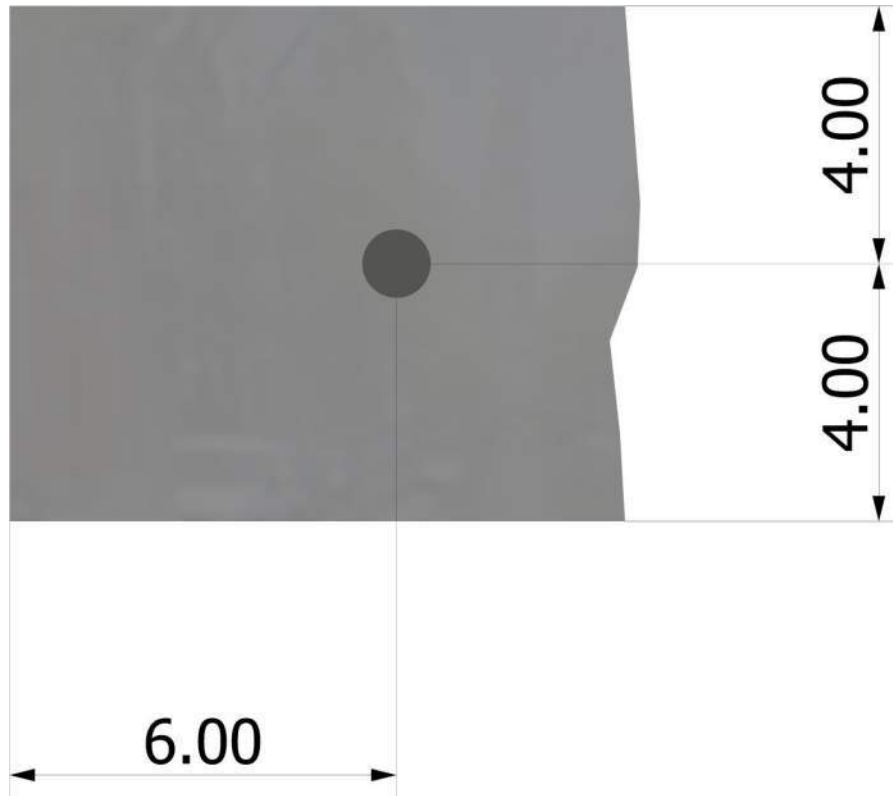

Recommended Anchor

Anchor Name: PAB Pre-Assembled Anchor Bolt - PAB8H (1"Ø)





Company:	L120 Engineering & Design	Date:	1/14/2018
Engineer:	MRT	Page:	3/5
Project:	Hold-down Anchors		
Address:			
Phone:			
E-mail:			

3. Resulting Anchor Forces

Anchor	Tension load, N _{ua} (lb)	Shear load x, V _{uax} (lb)	Shear load y, V _{uay} (lb)	Shear load combined, $\sqrt{(V_{uax})^2 + (V_{uay})^2}$ (lb)
1	22500.0	0.0	0.0	0.0
Sum	22500.0	0.0	0.0	0.0

Maximum concrete compression strain (%): 0.00
 Maximum concrete compression stress (psi): 0
 Resultant tension force (lb): 0
 Resultant compression force (lb): 0
 Eccentricity of resultant tension forces in x-axis, e'_{Nx} (inch): 0.00
 Eccentricity of resultant tension forces in y-axis, e'_{Ny} (inch): 0.00

4. Steel Strength of Anchor in Tension (Sec. 17.4.1)

N _{sa} (lb)	φ	φN _{sa} (lb)
72720	0.75	54540

6. Pullout Strength of Anchor in Tension (Sec. 17.4.3)

$0.75 \phi N_{pn} = 0.75 \phi \psi_{c,P} N_p = 0.75 \phi \psi_{c,P} 8 A_{brg} f_c$ (Sec. 17.3.1, Eq. 17.4.3.1 & 17.4.3.4)

$\psi_{c,P}$	A _{brg} (in ²)	f _c (psi)	φ	0.75 φN _{pn} (lb)
1.0	5.15	2500	0.70	54117



Company:	L120 Engineering & Design	Date:	1/14/2018
Engineer:	MRT	Page:	4/5
Project:	Hold-down Anchors		
Address:			
Phone:			
E-mail:			

7. Side-Face Blowout Strength of Anchor in Tension (Sec. 17.4.4)

$$0.75 \phi N_{sb} = 0.75 \phi \left\{ (1 + c_{a2}/c_{a1}) / 4 \right\} \left\{ 160 c_{a1} \sqrt{A_{brg}} \lambda \sqrt{f'_c} \right\} \quad (\text{Sec. 17.3.1 \& Eq. 17.4.4.1})$$

c_{a1} (in)	c_{a2} (in)	A_{brg} (in ²)	λ_a	f'_c (psi)	ϕ	$0.75 \phi N_{sb}$ (lb)
4.00	6.00	5.15	1.00	2500	0.75	25540

11. Results

11. Interaction of Tensile and Shear Forces (Sec. D.7)?

Tension	Factored Load, N_{ua} (lb)	Design Strength, ϕN_n (lb)	Ratio	Status
Steel	22500	54540	0.41	Pass
Pullout	22500	54117	0.42	Pass
Side-face blowout	22500	25540	0.88	Pass (Governs)

PAB8H (1"Ø) with hef = 15.000 inch meets the selected design criteria.

ACI 318-14 Section 17.2.3.4.3(a) (i) & (ii) Calculations for Ductility requirement for tension load

Steel	Factored Load, N_{ua} (lb)	1.2 x Nominal Strength, N_n (lb)	Ratio	
Steel	22500	87264	25.8%	
Concrete	Nominal Strength, N_n (lb)	Nominal Strength, N_n (lb)	Ratio	
Pullout	22500	103080	21.8%	
Side-face blowout	22500	45405	49.6%	Governs

ACI 318-14 Section 17.2.3.4.3(a) (i) & (ii) is not satisfied since steel ratio does not govern.



Company:	L120 Engineering & Design	Date:	1/14/2018
Engineer:	MRT	Page:	5/5
Project:	Hold-down Anchors		
Address:			
Phone:			
E-mail:			

12. Warnings

- Minimum spacing and edge distance requirement of 6da per ACI 318 Sections 17.7.1 and 17.7.2 for torqued cast-in-place anchor is waived per designer option.
- Concrete breakout strength in tension has not been evaluated against applied tension load(s) per designer option. Refer to ACI 318 Section 17.3.2.1 for conditions where calculations of the concrete breakout strength may not be required.
- Brittle failure governs for tension. Governing anchor failure mode is brittle failure. Attachment shall be designed to satisfy the requirements of ACI 318-14 Section 17.2.3.4.3 for structures assigned to Seismic Design Category C, D, E, or F when the component of the strength level earthquake force applied to anchors exceeds 20 percent of the total factored anchor force associated with the same load combination. In case when ACI 318-14 Sections 17.2.3.4.3 (a)(iii) to (vi), (b), (c) or (d) is satisfied for tension loading, select appropriate checkbox from Inputs tab to disable this message. Alternatively, Ω_0 factor can be entered to satisfy ACI 318-14 Section 17.2.3.4.3(d) to increase the earthquake portion of the loads as required.
- Per designer input, the shear component of the strength-level earthquake force applied to anchors does not exceed 20 percent of the total factored anchor shear force associated with the same load combination. Therefore the ductility requirements of ACI 318 17.2.3.5.2 for shear need not be satisfied – designer to verify.
- Designer must exercise own judgement to determine if this design is suitable.



Company:	L120 Engineering & Design	Date:	1/14/2018
Engineer:	MRT	Page:	1/5
Project:	Hold-down Anchors		
Address:			
Phone:			
E-mail:			

1. Project information

Customer company:
Customer contact name:
Customer e-mail:
Comment:

Project description:
Location:
Fastening description:

1 1/8" DIA Anchor

2. Input Data & Anchor Parameters

General

Design method: ACI 318-14
Units: Imperial units

Anchor Information:

Anchor type: Cast-in-place
Material: AB
Diameter (inch): 1.125
Effective Embedment depth, h_{ef} (inch): 15.000
Anchor category: -
Anchor ductility: Yes
 h_{min} (inch): 17.75
 C_{min} (inch): 2.13
 S_{min} (inch): 4.50

Base Material

Concrete: Normal-weight
Concrete thickness, h (inch): 18.00
State: Cracked
Compressive strength, f_c (psi): 2500
 $\Psi_{c,v}$: 1.0
Reinforcement condition: A tension, A shear
Supplemental reinforcement: Not applicable
Reinforcement provided at corners: Yes
Ignore concrete breakout in tension: Yes
Ignore concrete breakout in shear: No
Ignore 6do requirement: Yes
Build-up grout pad: No

Load and Geometry

Load factor source: ACI 318 Section 5.3
Load combination: $U = 0.9D + 1.0E$
Seismic design: Yes
Anchors subjected to sustained tension: Not applicable
Ductility section for tension: 17.2.3.4.3 (a) (iii)-(vi) is satisfied
Ductility section for shear: 17.2.3.5.2 not applicable
 Ω_D factor: not set
Apply entire shear load at front row: No
Anchors only resisting wind and/or seismic loads: Yes

<Figure 1>

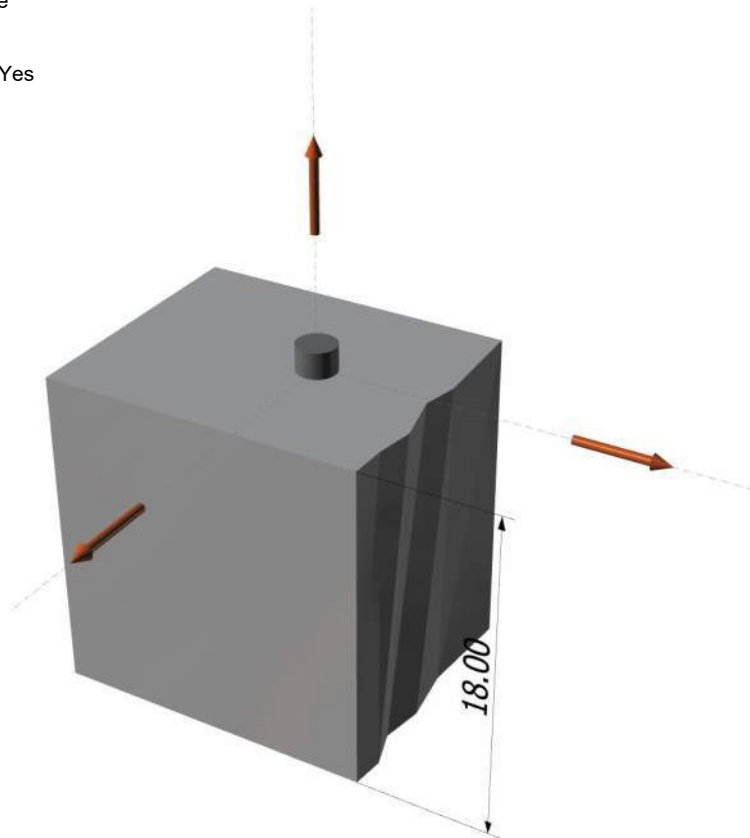

Input data and results must be checked for agreement with the existing circumstances, the standards and guidelines must be checked for plausibility.



Company:	L120 Engineering & Design	Date:	1/14/2018
Engineer:	MRT	Page:	2/5
Project:	Hold-down Anchors		
Address:			
Phone:			
E-mail:			

<Figure 2>

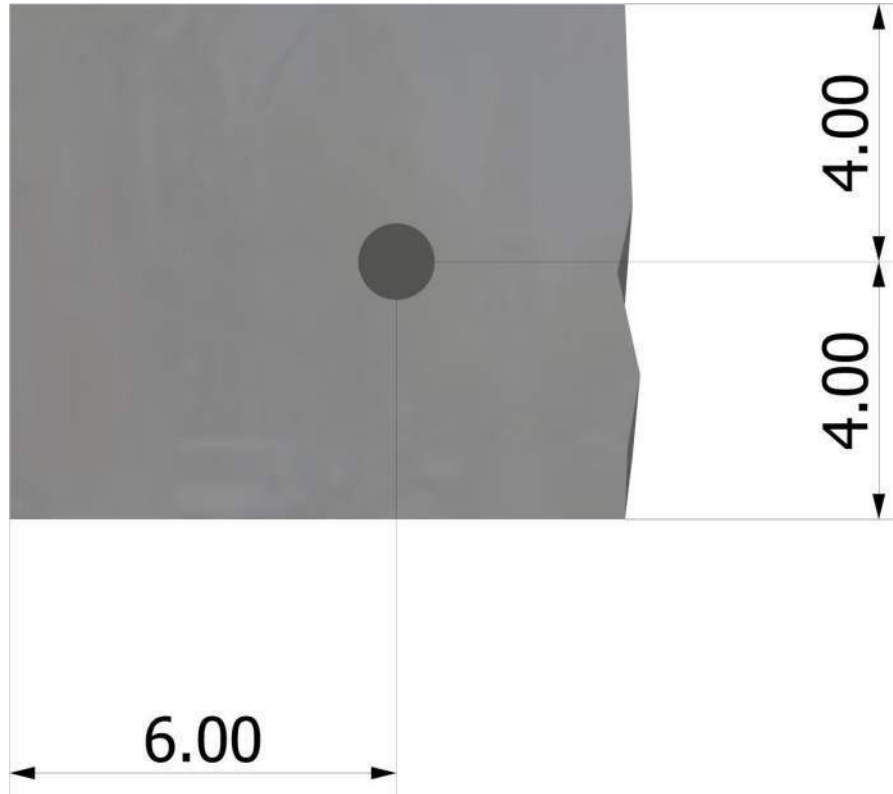

Recommended Anchor

Anchor Name: PAB Pre-Assembled Anchor Bolt - PAB9 (1 1/8"Ø)





Anchor Designer™
Software
Version 2.5.6582.0

Company:	L120 Engineering & Design	Date:	1/14/2018
Engineer:	MRT	Page:	3/5
Project:	Hold-down Anchors		
Address:			
Phone:			
E-mail:			

3. Resulting Anchor Forces

Anchor	Tension load, N _{ua} (lb)	Shear load x, V _{uax} (lb)	Shear load y, V _{uay} (lb)	Shear load combined, $\sqrt{(V_{uax})^2 + (V_{uay})^2}$ (lb)
1	27900.0	0.0	0.0	0.0
Sum	27900.0	0.0	0.0	0.0

Maximum concrete compression strain (%): 0.00
 Maximum concrete compression stress (psi): 0
 Resultant tension force (lb): 0
 Resultant compression force (lb): 0
 Eccentricity of resultant tension forces in x-axis, e'_{Nx} (inch): 0.00
 Eccentricity of resultant tension forces in y-axis, e'_{Ny} (inch): 0.00

4. Steel Strength of Anchor in Tension (Sec. 17.4.1)

N _{sa} (lb)	φ	φN _{sa} (lb)
44255	0.75	33191

6. Pullout Strength of Anchor in Tension (Sec. 17.4.3)

$0.75\phi N_{pn} = 0.75\phi\psi_{c,P}N_p = 0.75\phi\psi_{c,P}8A_{brg}f_c$ (Sec. 17.3.1, Eq. 17.4.3.1 & 17.4.3.4)

$\psi_{c,P}$	A _{brg} (in ²)	f _c (psi)	φ	0.75φN _{pn} (lb)
1.0	6.37	2500	0.70	66885

Input data and results must be checked for agreement with the existing circumstances, the standards and guidelines must be checked for plausibility.



Company:	L120 Engineering & Design	Date:	1/14/2018
Engineer:	MRT	Page:	4/5
Project:	Hold-down Anchors		
Address:			
Phone:			
E-mail:			

7. Side-Face Blowout Strength of Anchor in Tension (Sec. 17.4.4)

$$0.75\phi N_{sb} = 0.75\phi \left\{ (1 + c_{a2}/c_{a1})/4 \right\} (160c_{a1}\sqrt{A_{brg}})\lambda\sqrt{f'_c} \text{ (Sec. 17.3.1 \& Eq. 17.4.4.1)}$$

c_{a1} (in)	c_{a2} (in)	A_{brg} (in ²)	λ_a	f'_c (psi)	ϕ	$0.75\phi N_{sbg}$ (lb)
4.00	6.00	6.37	1.00	2500	0.75	28394

11. Results

11. Interaction of Tensile and Shear Forces (Sec. D.7)?

Tension	Factored Load, N_{ua} (lb)	Design Strength, ϕN_n (lb)	Ratio	Status
Steel	27900	33191	0.84	Pass
Pullout	27900	66885	0.42	Pass
Side-face blowout	27900	28394	0.98	Pass (Governs)

PAB9 (1 1/8"Ø) with hef = 15.000 inch meets the selected design criteria.

ACI 318-14 Section 17.2.3.4.3(a) (i) & (ii) Calculations for Ductility requirement for tension load

Steel	Factored Load, N_{ua} (lb)	1.2 x Nominal Strength, N_n (lb)	Ratio	
Steel	27900	53106	52.5%	
Concrete	Nominal Strength, N_n (lb)	Nominal Strength, N_n (lb)	Ratio	
Pullout	27900	127400	21.9%	
Side-face blowout	27900	50478	55.3%	Governs

ACI 318-14 Section 17.2.3.4.3(a) (i) & (ii) is not satisfied since steel ratio does not govern.



Company:	L120 Engineering & Design	Date:	1/14/2018
Engineer:	MRT	Page:	5/5
Project:	Hold-down Anchors		
Address:			
Phone:			
E-mail:			

12. Warnings

- Minimum spacing and edge distance requirement of 6da per ACI 318 Sections 17.7.1 and 17.7.2 for torqued cast-in-place anchor is waived per designer option.
- Concrete breakout strength in tension has not been evaluated against applied tension load(s) per designer option. Refer to ACI 318 Section 17.3.2.1 for conditions where calculations of the concrete breakout strength may not be required.
- Brittle failure governs for tension. Governing anchor failure mode is brittle failure. Attachment shall be designed to satisfy the requirements of ACI 318-14 Section 17.2.3.4.3 for structures assigned to Seismic Design Category C, D, E, or F when the component of the strength level earthquake force applied to anchors exceeds 20 percent of the total factored anchor force associated with the same load combination. In case when ACI 318-14 Sections 17.2.3.4.3 (a)(iii) to (vi), (b), (c) or (d) is satisfied for tension loading, select appropriate checkbox from Inputs tab to disable this message. Alternatively, Ω_0 factor can be entered to satisfy ACI 318-14 Section 17.2.3.4.3(d) to increase the earthquake portion of the loads as required.
- Per designer input, the shear component of the strength-level earthquake force applied to anchors does not exceed 20 percent of the total factored anchor shear force associated with the same load combination. Therefore the ductility requirements of ACI 318 17.2.3.5.2 for shear need not be satisfied – designer to verify.
- Designer must exercise own judgement to determine if this design is suitable.



Company:	L120 Engineering & Design	Date:	1/14/2018
Engineer:	MRT	Page:	1/5
Project:	Hold-down Anchors		
Address:			
Phone:			
E-mail:			

1. Project information

Customer company:
 Customer contact name:
 Customer e-mail:
 Comment:

Project description:
 Location:
 Fastening description:

1 1/4" DIA Anchor

2. Input Data & Anchor Parameters

General

Design method: ACI 318-14
 Units: Imperial units

Anchor Information:

Anchor type: Cast-in-place
 Material: AB
 Diameter (inch): 1.250
 Effective Embedment depth, h_{ef} (inch): 15.000
 Anchor category: -
 Anchor ductility: Yes
 h_{min} (inch): 18.00
 C_{min} (inch): 2.25
 S_{min} (inch): 5.00

Base Material

Concrete: Normal-weight
 Concrete thickness, h (inch): 18.00
 State: Cracked
 Compressive strength, f_c (psi): 2500
 $\Psi_{c,v}$: 1.0
 Reinforcement condition: A tension, A shear
 Supplemental reinforcement: Not applicable
 Reinforcement provided at corners: Yes
 Ignore concrete breakout in tension: Yes
 Ignore concrete breakout in shear: No
 Ignore 6do requirement: Yes
 Build-up grout pad: No

Load and Geometry

Load factor source: ACI 318 Section 5.3
 Load combination: $U = 0.9D + 1.0E$
 Seismic design: Yes
 Anchors subjected to sustained tension: Not applicable
 Ductility section for tension: 17.2.3.4.3 (a) (iii)-(vi) is satisfied
 Ductility section for shear: 17.2.3.5.2 not applicable
 Ω_0 factor: not set
 Apply entire shear load at front row: No
 Anchors only resisting wind and/or seismic loads: Yes

<Figure 1>

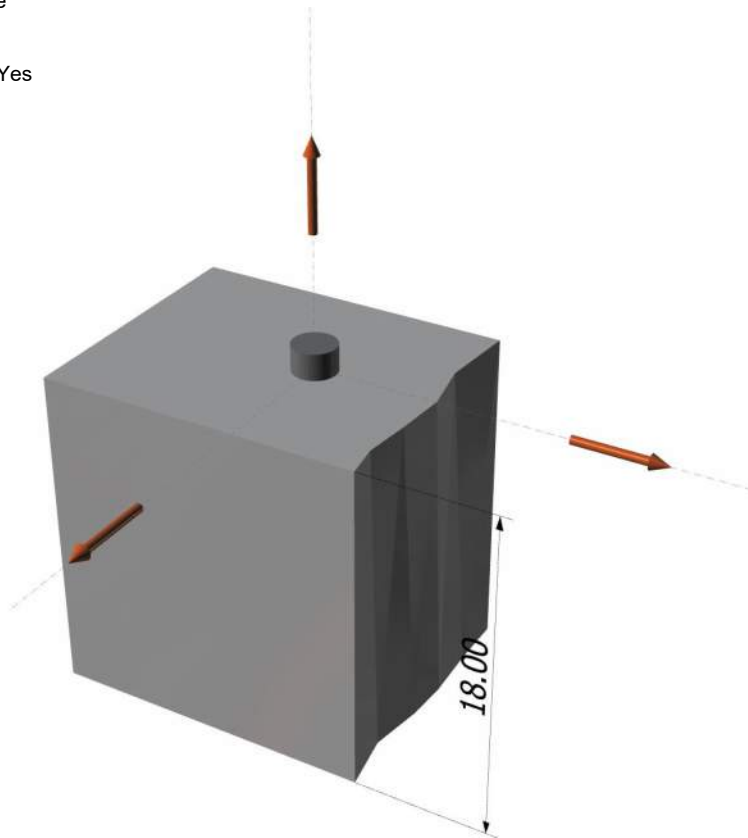



Company:	L120 Engineering & Design	Date:	1/14/2018
Engineer:	MRT	Page:	2/5
Project:	Hold-down Anchors		
Address:			
Phone:			
E-mail:			

<Figure 2>

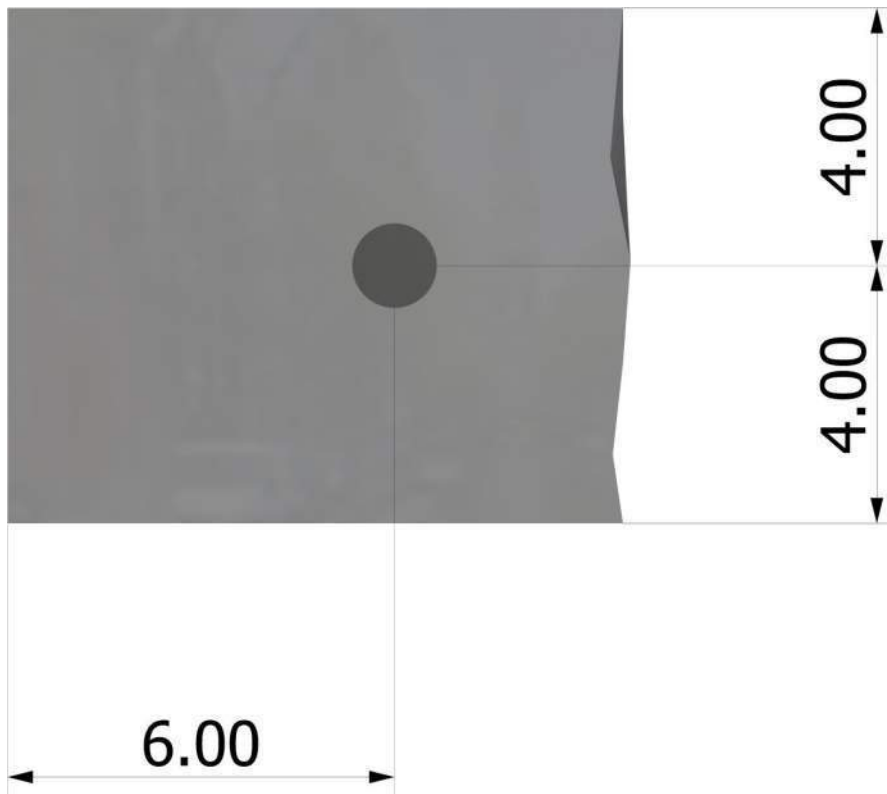

Recommended Anchor

Anchor Name: PAB Pre-Assembled Anchor Bolt - PAB10 (1 1/4"Ø)





Anchor Designer™
Software
 Version 2.5.6582.0

Company:	L120 Engineering & Design	Date:	1/14/2018
Engineer:	MRT	Page:	3/5
Project:	Hold-down Anchors		
Address:			
Phone:			
E-mail:			

3. Resulting Anchor Forces

Anchor	Tension load, N _{ua} (lb)	Shear load x, V _{uax} (lb)	Shear load y, V _{uay} (lb)	Shear load combined, $\sqrt{(V_{uax})^2 + (V_{uay})^2}$ (lb)
1	31500.0	0.0	0.0	0.0
Sum	31500.0	0.0	0.0	0.0

Maximum concrete compression strain (%): 0.00
 Maximum concrete compression stress (psi): 0
 Resultant tension force (lb): 0
 Resultant compression force (lb): 0
 Eccentricity of resultant tension forces in x-axis, e'_{Nx} (inch): 0.00
 Eccentricity of resultant tension forces in y-axis, e'_{Ny} (inch): 0.00

4. Steel Strength of Anchor in Tension (Sec. 17.4.1)

N _{sa} (lb)	φ	φN _{sa} (lb)
56200	0.75	42150

6. Pullout Strength of Anchor in Tension (Sec. 17.4.3)

$0.75 \phi N_{pn} = 0.75 \phi \psi_{c,P} N_p = 0.75 \phi \psi_{c,P} 8 A_{brg} f_c$ (Sec. 17.3.1, Eq. 17.4.3.1 & 17.4.3.4)

$\psi_{c,P}$	A _{brg} (in ²)	f _c (psi)	φ	0.75 φN _{pn} (lb)
1.0	8.39	2500	0.70	88137

Input data and results must be checked for agreement with the existing circumstances, the standards and guidelines must be checked for plausibility.



Company:	L120 Engineering & Design	Date:	1/14/2018
Engineer:	MRT	Page:	4/5
Project:	Hold-down Anchors		
Address:			
Phone:			
E-mail:			

7. Side-Face Blowout Strength of Anchor in Tension (Sec. 17.4.4)

$$0.75\phi N_{sb} = 0.75\phi \left\{ (1 + c_{a2}/c_{a1})/4 \right\} \left\{ 160c_{a1}\sqrt{A_{brg}} \lambda \sqrt{f'_c} \right\} \text{ (Sec. 17.3.1 \& Eq. 17.4.4.1)}$$

c_{a1} (in)	c_{a2} (in)	A_{brg} (in ²)	λ_a	f'_c (psi)	ϕ	$0.75\phi N_{sbg}$ (lb)
4.00	6.00	8.39	1.00	2500	0.75	32594

11. Results

11. Interaction of Tensile and Shear Forces (Sec. D.7)?

Tension	Factored Load, N_{ua} (lb)	Design Strength, ϕN_n (lb)	Ratio	Status
Steel	31500	42150	0.75	Pass
Pullout	31500	88137	0.36	Pass
Side-face blowout	31500	32594	0.97	Pass (Governs)

PAB10 (1 1/4"Ø) with hef = 15.000 inch meets the selected design criteria.

ACI 318-14 Section 17.2.3.4.3(a) (i) & (ii) Calculations for Ductility requirement for tension load

Steel	Factored Load, N_{ua} (lb)	1.2 x Nominal Strength, N_n (lb)	Ratio	
Steel	31500	67440	46.7%	
Concrete	Nominal Strength, N_n (lb)	Nominal Strength, N_n (lb)	Ratio	
Pullout	31500	167880	18.8%	
Side-face blowout	31500	57945	54.4%	Governs

ACI 318-14 Section 17.2.3.4.3(a) (i) & (ii) is not satisfied since steel ratio does not govern.



Company:	L120 Engineering & Design	Date:	1/14/2018
Engineer:	MRT	Page:	5/5
Project:	Hold-down Anchors		
Address:			
Phone:			
E-mail:			

12. Warnings

- Minimum spacing and edge distance requirement of 6da per ACI 318 Sections 17.7.1 and 17.7.2 for torqued cast-in-place anchor is waived per designer option.
- Concrete breakout strength in tension has not been evaluated against applied tension load(s) per designer option. Refer to ACI 318 Section 17.3.2.1 for conditions where calculations of the concrete breakout strength may not be required.
- Brittle failure governs for tension. Governing anchor failure mode is brittle failure. Attachment shall be designed to satisfy the requirements of ACI 318-14 Section 17.2.3.4.3 for structures assigned to Seismic Design Category C, D, E, or F when the component of the strength level earthquake force applied to anchors exceeds 20 percent of the total factored anchor force associated with the same load combination. In case when ACI 318-14 Sections 17.2.3.4.3 (a)(iii) to (vi), (b), (c) or (d) is satisfied for tension loading, select appropriate checkbox from Inputs tab to disable this message. Alternatively, Ω_0 factor can be entered to satisfy ACI 318-14 Section 17.2.3.4.3(d) to increase the earthquake portion of the loads as required.
- Per designer input, the shear component of the strength-level earthquake force applied to anchors does not exceed 20 percent of the total factored anchor shear force associated with the same load combination. Therefore the ductility requirements of ACI 318 17.2.3.5.2 for shear need not be satisfied – designer to verify.
- Designer must exercise own judgement to determine if this design is suitable.



LONGITUDE
ONE TWENTY[°]
ENGINEERING & DESIGN

Hand-rail Calculations

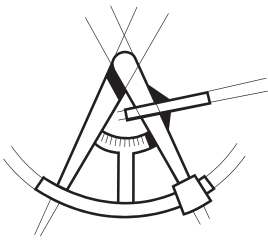

LONGITUDE
ONE TWENTY[°]
 ENGINEERING & DESIGN

PROJECT NO.	SHEET NO.

PROJECT _____

SUBJECT GuardRail Design

BY _____ DATE ____ / ____ / ____

End Post Anchor Bolt Design:

$P_v = 25 \text{ lbs}$

$P_h = 200 \text{ lbs}$

$h_1 = 46''$

$h_2 = 5.5''$

$e = 1.5''$

Anchor Moment $M_x = P_v(e) + P_h (h_1 + h_2/2)$
 $= 25 \times 1.5 + 200 \times (46 + 5.5/2)$
 $= 9788 \text{ #''}$

$M_y = 200\# \times 4.5'' = 900 \text{ #''}$

Anchor Forces $T = [P_v (e) + P_h (h_1 + h_2)] / h_2 + M_y / 1.5''$
 $= 2480 \text{ #}$

Anchor Forces $C = T - P_h$
 $= 2280 \text{ #}$

Each Bolt Force $T = T / 2 = 1240 \text{ #}$
 $V = P_v / 4 + P_v \times 4.5'' / (4 \times 2.85'') = 16 \text{ #}$

Wood Lag Screw: 3/8" dia with 3" min. embed into DF beam.

Withdrawal $W_a = 305 \text{ #/''} \times 1.6 \times 3'' = 1460 \text{ #} > T \text{ O.K.}$
 Shear $Z_a = 180 \text{ #} \times 1.6 = 280 \text{ #} \text{ O.K.}$

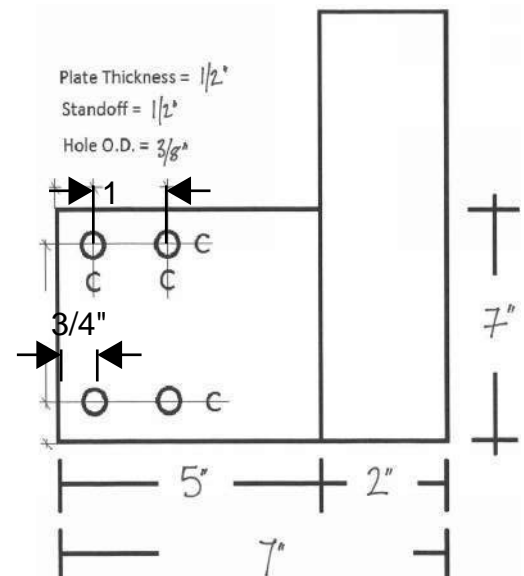
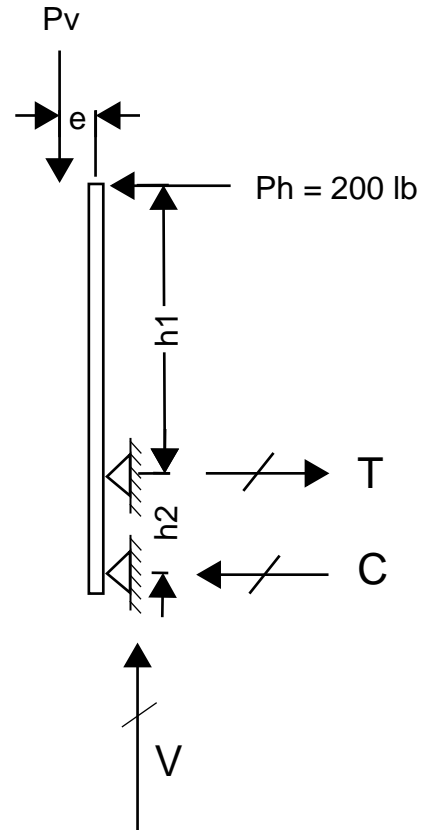

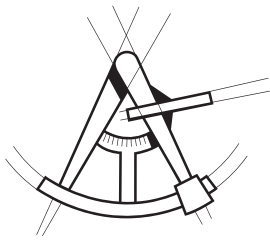

LONGITUDE
ONE TWENTY°
 ENGINEERING & DESIGN

PROJECT NO.	SHEET NO.

PROJECT _____

SUBJECT GuardRail Design

BY _____ DATE ____ / ____ / ____

Middle Post Anchor Bolt Design:

$P_v = 25 \text{ lbs}$

$P_h = 250 \text{ lbs}$

$h_1 = 46''$

$h_2 = 5.5''$

$e = 1.5''$

Anchor Moment $M = P_v(e) + P_h (h_1 + h_2/2)$
 $= 25 \times 1.5 + 250 (46 + 5.5/2)$
 $= 12,250$

Anchor Forces $T = [P_v (e) + P_h (h_1 + h_2)] / h_2$
 $= 2347 \#$

Anchor Forces $C = T - P_h$
 $= 2147 \#$

Each Bolt Force $T = T / 2 = 1174 \#$
 $V = P_v / 4 = 6 \#$

Wood Lag Screw: 3/8" dia with 3" min. embed into DF beam.

Withdrawal $W_a = 305 \#/' \times 1.6 \times 3'' = 1460 \# > T$ O.K.
 Shear $Z_a = 180 \# \times 1.6 = 280 \#$ O.K.

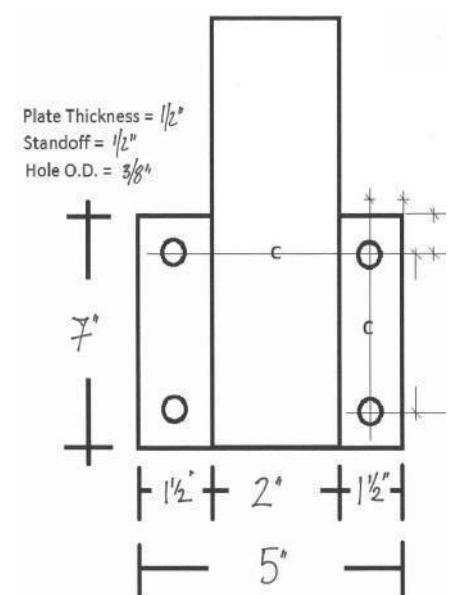
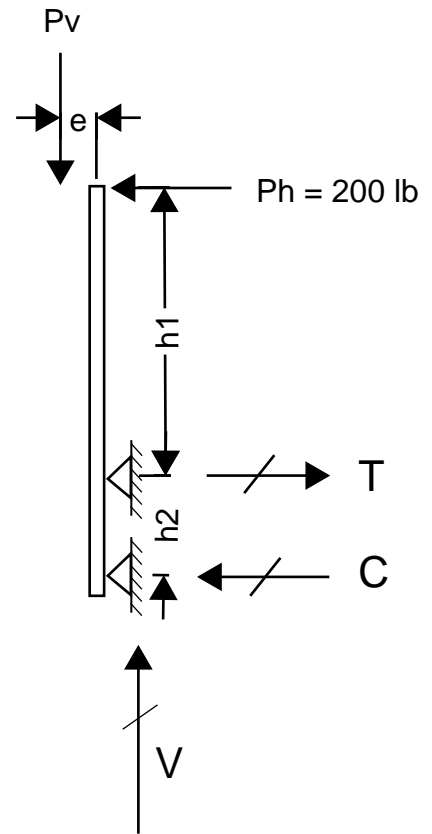

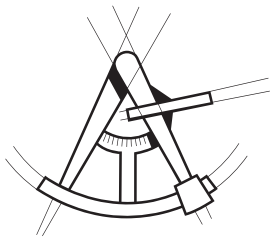

LONGITUDE

ONE TWENTY°

ENGINEERING & DESIGN

PROJECT NO.	SHEET NO.

PROJECT _____

SUBJECT GuardRail Design

BY _____ DATE ____ / ____ / ____

Mounting Plate Design:

Apply Forces: $M_x = 9788 \text{ #"}^2$
 $M_y = 900 \text{ #"}^2$
 $T = 200 \text{ #}$
 $V = 25 \text{ #}$

Try 1/2" thick Plate

Plate Bending Stress: $f_{bx} = M_x/2/S_x$
 $= 9788/2/(1/4 \times 5" \times (1/2)^2)$
 $= 15,660 \text{ psi}$
 $f_{by} = M_y/S_y$
 $= 900/(1/4 \times 7" \times (1/2)^2)$
 $= 2,057 \text{ psi}$

For Plate 6061-T6 $F_b = 35 \text{ ksi} / 1.65$
 $= 21,200 \text{ psi} > f_b \text{ O.K.}$

Plate Combined Stress
 $f_{bx}/F_b + f_{by}/F_b = 0.83 < 1.0 \text{ O.K.}$

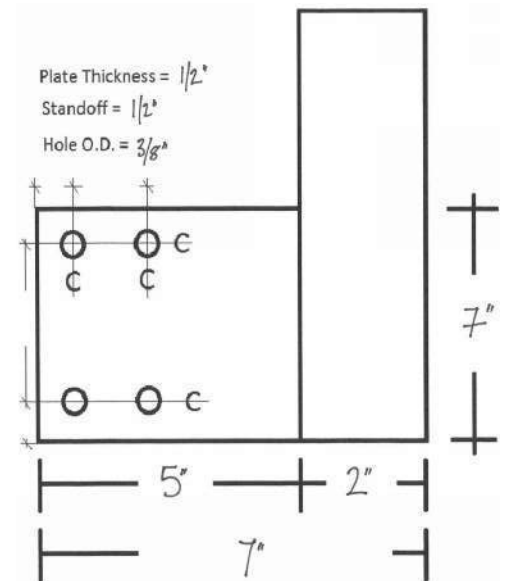

Hex Lag Screws, Hot Dipped Galvanized

The information below lists the required dimensional, chemical and physical characteristics of the products in this purchase order. If the order received does not meet these requirements, it may result in a supplier corrective action request, which could jeopardize your status as an approved vendor. Unless otherwise specified, all referenced consensus standards must be adhered to in their entirety.

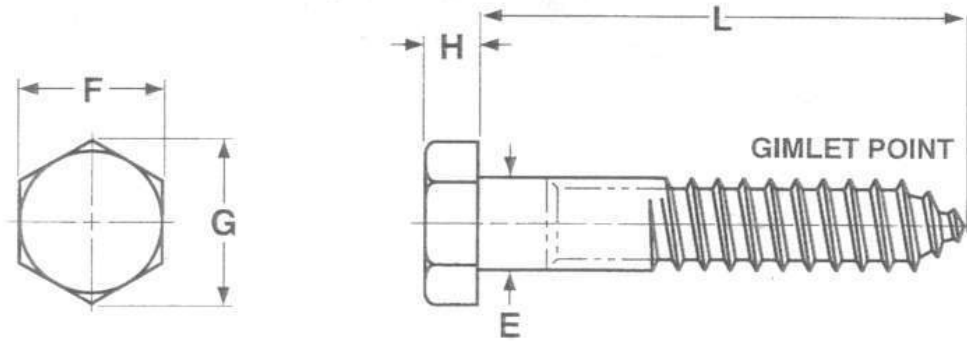

Diameter	E		F		G		H	
	Body Diameter		Width Across Flats		Width Across Corners		Height	
	Max.	Min.	Max.	Min.	Max.	Min.	Max.	Min.
10	.199	.178	.281	.271	.323	.309	.140	.110
1/4	.260	.237	.438	.425	.505	.484	.188	.150
5/16	.324	.298	.500	.484	.577	.552	.235	.195
3/8	.388	.360	.562	.544	.650	.620	.268	.226
7/16	.452	.421	.625	.603	.722	.687	.316	.272
1/2	.515	.482	.750	.725	.866	.826	.364	.302
5/8	.642	.605	.938	.906	1.083	1.033	.444	.378
3/4	.768	.729	1.125	1.088	1.299	1.240	.524	.455
7/8	.895	.852	1.312	1.269	1.516	1.447	.604	.531
1	1.022	.976	1.500	1.450	1.732	1.653	.700	.591
1 1/8	1.149	1.098	1.688	1.631	1.949	1.859	.780	.658
1 1/4	1.277	1.223	1.875	1.812	2.165	2.066	.876	.749

Dimensions above are prior to coating

Specification Requirements:

- Dimensions: ASME B18.2.1.
- Material: Per ASTM A307, Grade A
- Thread requirements: The minimum thread length must be equal to one half the nominal Screw length plus 1/2", or 6 inch, whichever is shorter. Screws too short to conform to this formula must be threaded as close to the head as possible.
- Coating: Hot Dip Zinc per ASTM F2329 or in accordance with Class C of ASTM A153 and Class D for 3/8" diameter and less.

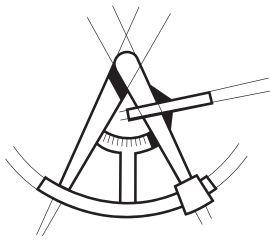

PROJECT _____
 SUBJECT _____
 BY _____ DATE ____ / ____ / ____

Table 2.3.2 Frequently Used Load Duration Factors, C_D ¹

Load Duration	C_D	Typical Design Loads
Permanent	0.9	Dead Load
Ten years	1.0	Occupancy Live Load
Two months	1.15	Snow Load
Seven days	1.25	Construction Load
Ten minutes	1.6	Wind/Earthquake Load
Impact ²	2.0	Impact Load

1. Load duration factors shall not apply to reference modulus of elasticity, E , reference modulus of elasticity for beam and column stability, E_{min} , nor to reference compression perpendicular to grain design values, $F_{c\perp}$, based on a deformation limit.
2. Load duration factors greater than 1.6 shall not apply to structural members pressure-treated with water-borne preservatives (see Reference 30), or fire retardant chemicals. The impact load duration factor shall not apply to connections.

2.3.3 Temperature Factor, C_t

Reference design values shall be multiplied by the temperature factors, C_t , in Table 2.3.3 for structural members that will experience sustained exposure to elevated temperatures up to 150°F (see Appendix C).

2.3.4 Fire Retardant Treatment

The effects of fire retardant chemical treatment on strength shall be accounted for in the design. Adjusted design values, including adjusted connection design values, for lumber and structural glued laminated timber pressure-treated with fire retardant chemicals shall be obtained from the company providing the treatment and redrying service. Load duration factors greater than 1.6 shall not apply to structural members pressure-treated with fire retardant chemicals (see Table 2.3.2).

2.3.5 Format Conversion Factor, K_F (LRFD Only)

For LRFD, reference design values shall be multiplied by the format conversion factor, K_F , specified in Table 2.3.5. The format conversion factor, K_F , shall not apply for designs in accordance with ASD methods specified herein.

2.3.6 Resistance Factor, ϕ (LRFD Only)

For LRFD, reference design values shall be multiplied by the resistance factor, ϕ , specified in Table 2.3.6. The resistance factor, ϕ , shall not apply for designs in accordance with ASD methods specified herein.

2.3.7 Time Effect Factor, λ (LRFD Only)

For LRFD, reference design values shall be multiplied by the time effect factor, λ , specified in Appendix N.3.3. The time effect factor, λ , shall not apply for designs in accordance with ASD methods specified herein.

2
 DESIGN VALUES FOR STRUCTURAL MEMBERS

Table 2.3.3 Temperature Factor, C_t

Reference Design Values	In-Service Moisture Conditions ¹	C_t		
		$T \leq 100^\circ\text{F}$	$100^\circ\text{F} < T \leq 125^\circ\text{F}$	$125^\circ\text{F} < T \leq 150^\circ\text{F}$
F_t, E, E_{min}	Wet or Dry	1.0	0.9	0.9
$F_b, F_v, F_c,$ and $F_{c\perp}$	Dry	1.0	0.8	0.7
	Wet	1.0	0.7	0.5

1. Wet and dry service conditions for sawn lumber, structural glued laminated timber, prefabricated wood I-joists, structural composite lumber, wood structural panels and cross-laminated timber are specified in 4.1.4, 5.1.4, 7.1.4, 8.1.4, 9.3.3, and 10.1.5 respectively.

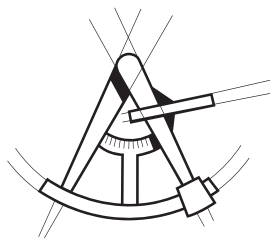

PROJECT _____
 SUBJECT _____
 BY _____ DATE ____ / ____ / ____

Table 11.3.1 Applicability of Adjustment Factors for Connections

	ASD Only	ASD and LRFD										LRFD Only		
		Load Duration Factor ¹	Wet Service Factor	Temperature Factor	Group Action Factor	Geometry Factor ³	Penetration Depth Factor ³	End Grain Factor ³	Metal Side Plate Factor ³	Diaphragm Factor ³	Toe-Nail Factor ³	Format Conversion Factor	Resistance Factor	Time Effect Factor
		C_D	C_M	C_t	C_g	C_A	C_d	C_{eg}	C_a	C_{di}	C_{tn}	K_F	ϕ	
Lateral Loads														
Dowel-type Fasteners (e.g. bolts, lag screws, wood screws, nails, spikes, drift bolts, & drift pins)	$Z = Z \times$	C_D	C_M	C_t	C_g	C_A	-	C_{eg}	-	C_{di}	C_{tn}	3.32	0.65	λ
Split Ring and Shear Plate Connectors	$P = P \times$	C_D	C_M	C_t	C_g	C_A	C_d	-	C_{st}	-	-	3.32	0.65	λ
	$Q = Q \times$	C_D	C_M	C_t	C_g	C_A	C_d	-	-	-	-	3.32	0.65	λ
Timber Rivets	$P = P \times$	C_D	C_M	C_t	-	-	-	-	C_{st}^4	-	-	3.32	0.65	λ
	$Q = Q \times$	C_D	C_M	C_t	-	C_A^5	-	-	C_{st}^4	-	-	3.32	0.65	λ
Spike Grids	$Z = Z \times$	C_D	C_M	C_t	-	C_A	-	-	-	-	-	3.32	0.65	λ
Withdrawal Loads														
Nails, spikes, lag screws, wood screws, & drift pins	$W = W \times$	C_D	C_M^2	C_t	-	-	-	C_{eg}	-	-	C_{tn}	3.32	0.65	λ

1. The load duration factor, C_D , shall not exceed 1.6 for connections (see 11.3.2).
 2. The wet service factor, C_M , shall not apply to toe-nails loaded in withdrawal (see 12.5.4.1).
 3. Specific information concerning geometry factors C_A , penetration depth factors C_d , end grain factors, C_{eg} , metal side plate factors, C_a , diaphragm factors, C_{di} , and toe-nail factors, C_{tn} , is provided in Chapters 12, 13, and 14.
 4. The metal side plate factor, C_a , is only applied when rivet capacity (P, Q) controls (see Chapter 14).
 5. The geometry factor, C_A , is only applied when wood capacity, Q_w , controls (see Chapter 14).

11.3.2 Load Duration Factor, C_D (ASD Only)

Reference design values shall be multiplied by the load duration factors, $C_D \leq 1.6$, specified in 2.3.2 and Appendix B, except when the capacity of the connection is controlled by metal strength or strength of concrete/masonry (see 11.2.3, 11.2.4, and Appendix B.3). The impact load duration factor shall not apply to connections.

11.3.3 Wet Service Factor, C_M

Reference design values are for connections in wood seasoned to a moisture content of 19% or less and used under continuously dry conditions, as in most covered structures. For connections in wood that is unseasoned or partially seasoned, or when connections are exposed to wet service conditions in use, reference design values shall be multiplied by the wet service factors, C_M , specified in Table 11.3.3.

soned or partially seasoned, or when connections are exposed to wet service conditions in use, reference design values shall be multiplied by the wet service factors, C_M , specified in Table 11.3.3.

11.3.4 Temperature Factor, C_t

Reference design values shall be multiplied by the temperature factors, C_t , in Table 11.3.4 for connections that will experience sustained exposure to elevated temperatures up to 150°F (see Appendix C).

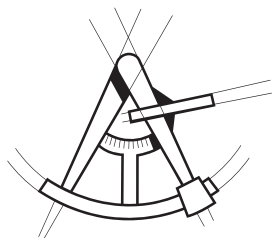

PROJECT _____
SUBJECT _____
BY _____ DATE ____ / ____ / ____

Table 12.2A Lag Screw Reference Withdrawal Design Values, W¹

Tabulated withdrawal design values (W) are in pounds per inch of thread penetration into side grain of wood member. Length of thread penetration in main member shall not include the length of the tapered tip (see 12.2.1.1).

Specific Gravity, G ²	Lag Screw Diameter, D										
	1/4"	5/16"	3/8"	7/16"	1/2"	5/8"	3/4"	7/8"	1"	1-1/8"	1-1/4"
0.73	397	469	538	604	668	789	905	1016	1123	1226	1327
0.71	381	450	516	579	640	757	868	974	1077	1176	1273
0.68	357	422	484	543	600	709	813	913	1009	1103	1193
0.67	349	413	473	531	587	694	796	893	987	1078	1167
0.58	281	332	381	428	473	559	641	719	795	869	940
0.55	260	307	352	395	437	516	592	664	734	802	868
0.51	232	274	314	353	390	461	528	593	656	716	775
0.50	225	266	305	342	378	447	513	576	636	695	752
0.49	218	258	296	332	367	434	498	559	617	674	730
0.47	205	242	278	312	345	408	467	525	580	634	686
0.46	199	235	269	302	334	395	453	508	562	613	664
0.44	186	220	252	283	312	369	423	475	525	574	621
0.43	179	212	243	273	302	357	409	459	508	554	600
0.42	173	205	235	264	291	344	395	443	490	535	579
0.41	167	198	226	254	281	332	381	428	473	516	559
0.40	161	190	218	245	271	320	367	412	455	497	538
0.39	155	183	210	236	261	308	353	397	438	479	518
0.38	149	176	202	227	251	296	340	381	422	461	498
0.37	143	169	194	218	241	285	326	367	405	443	479
0.36	137	163	186	209	231	273	313	352	389	425	460
0.35	132	156	179	200	222	262	300	337	373	407	441
0.31	110	130	149	167	185	218	250	281	311	339	367

1. Tabulated withdrawal design values, W, for lag screw connections shall be multiplied by all applicable adjustment factors (see Table 11.3.1).
2. Specific gravity, G, shall be determined in accordance with Table 12.3.3A.

12.2.3.2 For calculation of the fastener reference withdrawal design value in pounds, the unit reference withdrawal design value in lbs/in. of fastener penetration from 12.2.3.1 shall be multiplied by the length of fastener penetration, p_b, into the wood member.

12.2.3.3 The reference withdrawal design value, in lbs/in. of penetration, for a single post-frame ring shank nail driven in the side grain of the main member, with the nail axis perpendicular to the wood fibers, shall be determined from Table 12.2D or Equation 12.2-4, within the range of specific gravities and nail diameters given in Table 12.2D. Reference withdrawal design values, W, shall be multiplied by all applicable adjustment factors (see Table 11.3.1) to obtain adjusted withdrawal design values, W¹.

$$W = 1800 G^2 D \quad (12.2-4)$$

12.2.3.4 For calculation of the fastener reference withdrawal design value in pounds, the unit reference withdrawal design value in lbs/in. of ring shank penetration from 12.2.3.3 shall be multiplied by the length of ring shank penetration, p_b, into the wood member.

12.2.3.5 Nails and spikes shall not be loaded in withdrawal from end grain of wood (C_{eg}=0.0).

12.2.3.6 Nails, and spikes shall not be loaded in withdrawal from end-grain of laminations in cross-laminated timber (C_{eg}=0.0).

12.2.4 Drift Bolts and Drift Pins

Reference withdrawal design values, W, for connections using drift bolt and drift pin connections shall be determined in accordance with 11.1.1.3.

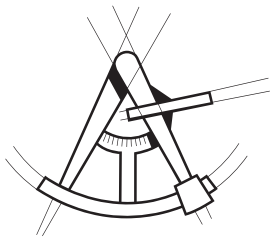

LONGITUDE
ONE TWENTY°
 ENGINEERING & DESIGN

PROJECT NO.	SHEET NO.

PROJECT _____
 SUBJECT _____
 BY _____ DATE ____ / ____ / ____

Table 12.3.3A Assigned Specific Gravities

Species Combination	Specific ¹ Gravity, G	Species Combinations of MSR and MEL Lumber	Specific ¹ Gravity, G
Alaska Cedar	0.47	Douglas Fir-Larch	
Alaska Hemlock	0.46	E=1,900,000 psi and lower grades of MSR	0.50
Alaska Spruce	0.41	E=2,000,000 psi grades of MSR	0.51
Alaska Yellow Cedar	0.46	E=2,100,000 psi grades of MSR	0.52
Aspen	0.39	E=2,200,000 psi grades of MSR	0.53
Balsam Fir	0.36	E=2,300,000 psi grades of MSR	0.54
Beech-Birch-Hickory	0.71	E=2,400,000 psi grades of MSR	0.55
Coast Sitka Spruce	0.39	Douglas Fir-Larch (North)	
Cottonwood	0.41	E=1,900,000 psi and lower grades of MSR and MEL	0.49
Douglas Fir-Larch	0.50	E=2,000,000 psi to 2,200,000 psi grades of MSR and MEL	0.53
Douglas Fir-Larch (North)	0.49	E=2,300,000 psi and higher grades of MSR and MEL	0.57
Douglas Fir-South	0.46	Douglas Fir-Larch (South)	
Eastern Hemlock	0.41	E=1,000,000 psi and higher grades of MSR	0.46
Eastern Hemlock-Balsam Fir	0.36	Engelmann Spruce-Lodgepole Pine	
Eastern Hemlock-Tamarack	0.41	E=1,400,000 psi and lower grades of MSR	0.38
Eastern Hemlock-Tamarack (North)	0.47	E=1,500,000 psi and higher grades of MSR	0.46
Eastern Softwoods	0.36	Hem-Fir	
Eastern Spruce	0.41	E=1,500,000 psi and lower grades of MSR	0.43
Eastern White Pine	0.36	E=1,600,000 psi grades of MSR	0.44
Engelmann Spruce-Lodgepole Pine	0.38	E=1,700,000 psi grades of MSR	0.45
Hem-Fir	0.43	E=1,800,000 psi grades of MSR	0.46
Hem-Fir (North)	0.46	E=1,900,000 psi grades of MSR	0.47
Mixed Maple	0.55	E=2,000,000 psi grades of MSR	0.48
Mixed Oak	0.68	E=2,100,000 psi grades of MSR	0.49
Mixed Southern Pine	0.51	E=2,200,000 psi grades of MSR	0.50
Mountain Hemlock	0.47	E=2,300,000 psi grades of MSR	0.51
Northern Pine	0.42	E=2,400,000 psi grades of MSR	0.52
Northern Red Oak	0.68	Hem-Fir (North)	
Northern Species	0.35	E=1,000,000 psi and higher grades of MSR and MEL	0.46
Northern White Cedar	0.31	Southern Pine	
Ponderosa Pine	0.43	E=1,700,000 psi and lower grades of MSR and MEL	0.55
Red Maple	0.58	E=1,800,000 psi and higher grades of MSR and MEL	0.57
Red Oak	0.67	Spruce-Pine-Fir	
Red Pine	0.44	E=1,700,000 psi and lower grades of MSR and MEL	0.42
Redwood, close grain	0.44	E=1,800,000 psi and 1,900,000 grades of MSR and MEL	0.46
Redwood, open grain	0.37	E=2,000,000 psi and higher grades of MSR and MEL	0.50
Sitka Spruce	0.43	Spruce-Pine-Fir (South)	
Southern Pine	0.55	E=1,100,000 psi and lower grades of MSR	0.36
Spruce-Pine-Fir	0.42	E=1,200,000 psi to 1,900,000 psi grades of MSR	0.42
Spruce-Pine-Fir (South)	0.36	E=2,000,000 psi and higher grades of MSR	0.50
Western Cedars	0.36	Western Cedars	
Western Cedars (North)	0.35	E=1,000,000 psi and higher grades of MSR	0.36
Western Hemlock	0.47	Western Woods	
Western Hemlock (North)	0.46	E=1,000,000 psi and higher grades of MSR	0.36
Western White Pine	0.40		
Western Woods	0.36		
White Oak	0.73		
Yellow Poplar	0.43		

1. Specific gravity, G, based on weight and volume when oven-dry. Different specific gravities, G, are possible for different grades of MSR and MEL lumber (see Table 4C, Footnote 2).

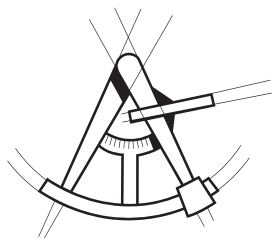

LONGITUDE
ONE TWENTY^o
 ENGINEERING & DESIGN

PROJECT NO.	SHEET NO.

PROJECT _____
 SUBJECT _____
 BY _____ DATE ____ / ____ / ____

LAG SCREWS

Table 12K LAG SCREWS: Reference Lateral Design Values, Z, for Single Shear (two member) Connections^{1,2,3,4}

for sawn lumber or SCL with ASTM A653, Grade 33 steel side plate (for $t_s < 1/4"$) or ASTM A 36 steel side plate (for $t_s = 1/4"$)
 (tabulated lateral design values are calculated based on an assumed length of lag screw penetration, p, into the main member equal to 8D)



Side Member Thickness t_s in.	Lag Screw Diameter D in.	G=0.67 Red Oak		G=0.55 Mixed Maple Southern Pine		G=0.5 Douglas Fir/Larch		G=0.49 Douglas Fir/Larch (N)		G=0.46 Douglas Fir(S) Hem-Fir(N)		G=0.43 Hem-Fir		G=0.42 Spruce-Pine-Fir		G=0.37 Redwood (open grain)		G=0.36 Eastern Softwoods Spruce-Pine-Fir(S) Western Cedars Western Woods		G=0.35 Northern Species	
		$Z_{ }$ lbs.	Z_{\perp} lbs.	$Z_{ }$ lbs.	Z_{\perp} lbs.	$Z_{ }$ lbs.	Z_{\perp} lbs.	$Z_{ }$ lbs.	Z_{\perp} lbs.	$Z_{ }$ lbs.	Z_{\perp} lbs.	$Z_{ }$ lbs.	Z_{\perp} lbs.	$Z_{ }$ lbs.	Z_{\perp} lbs.	$Z_{ }$ lbs.	Z_{\perp} lbs.	$Z_{ }$ lbs.	Z_{\perp} lbs.	$Z_{ }$ lbs.	Z_{\perp} lbs.
0.075 (14 gage)	1/4	170	130	160	120	150	110	150	110	150	100	140	100	140	100	130	90	130	90	130	90
	5/16	220	160	200	140	190	130	190	130	190	130	180	120	180	120	170	110	170	110	160	100
	3/8	220	160	200	140	200	130	190	130	190	120	180	120	180	120	170	110	170	100	170	100
0.105 (12 gage)	1/4	180	140	170	130	160	120	160	120	160	110	150	110	150	110	140	100	140	100	140	90
	5/16	230	170	210	150	200	140	200	140	190	130	190	130	190	120	180	110	170	110	170	110
	3/8	230	160	210	140	200	140	200	130	200	130	190	120	190	120	180	110	180	110	170	110
0.120 (11 gage)	1/4	190	150	180	130	170	120	170	120	160	120	160	110	160	110	150	100	150	100	140	100
	5/16	230	170	210	150	210	140	200	140	200	140	190	130	190	130	180	120	180	120	180	110
	3/8	240	170	220	150	210	140	210	130	200	130	200	130	190	120	180	110	180	110	180	110
0.134 (10 gage)	1/4	200	150	180	140	180	130	170	120	170	120	160	120	160	110	150	110	150	100	150	100
	5/16	240	180	220	160	210	150	210	140	200	140	200	130	200	130	190	120	180	120	180	120
	3/8	240	170	220	150	220	140	210	140	210	140	200	130	200	130	190	120	190	120	180	110
0.179 (7 gage)	1/4	220	170	210	150	200	150	200	140	190	140	190	130	190	130	180	120	170	120	170	120
	5/16	260	190	240	170	230	160	230	160	230	150	220	150	220	150	210	130	200	130	200	130
	3/8	270	190	250	170	240	160	240	160	230	150	220	140	220	140	210	130	210	130	200	130
0.239 (3 gage)	1/4	240	180	220	160	210	150	210	150	200	140	190	140	190	130	180	120	180	120	180	120
	5/16	300	220	280	190	270	180	260	180	260	170	250	160	250	160	230	150	230	150	230	140
	3/8	310	220	280	190	270	180	270	180	260	170	250	160	250	160	240	140	230	140	230	140
	7/16	420	290	390	260	380	240	370	240	360	230	350	220	350	220	330	200	330	200	320	190
	1/2	510	340	470	300	460	290	450	280	440	270	430	260	420	260	400	240	400	230	390	230
	5/8	770	490	710	430	680	400	660	400	660	380	640	370	630	360	600	330	590	330	580	320
	3/4	1110	670	1020	590	980	560	970	550	950	530	920	500	910	500	860	450	850	450	840	440
	7/8	1510	880	1390	780	1330	730	1320	710	1280	690	1250	650	1230	650	1170	590	1160	590	1140	570
1	1940	1100	1780	960	1710	910	1700	890	1650	860	1600	820	1590	810	1500	740	1480	730	1460	710	
1/4	1/4	240	180	220	160	210	150	210	150	200	140	200	140	190	130	180	120	180	120	180	120
	5/16	310	220	280	200	270	180	270	180	260	170	250	170	250	160	230	150	230	150	230	140
	3/8	320	220	290	190	280	180	270	180	270	170	260	160	250	160	240	150	240	140	230	140
	7/16	480	320	440	280	420	270	420	260	410	250	390	240	390	230	370	220	360	210	360	210
	1/2	580	390	540	340	520	320	510	320	500	310	480	290	480	290	460	270	450	260	440	260
	5/8	850	530	780	470	750	440	740	440	720	420	700	400	690	400	660	370	650	360	640	350
	3/4	1200	730	1100	640	1060	600	1050	590	1020	570	990	540	980	530	930	490	920	480	900	470
	7/8	1600	930	1470	820	1410	770	1400	750	1360	720	1320	690	1310	680	1240	630	1220	620	1200	600
1	2040	1150	1870	1000	1800	950	1780	930	1730	900	1680	850	1660	840	1570	770	1550	760	1530	740	

1. Tabulated lateral design values, Z, shall be multiplied by all applicable adjustment factors (see Table 11.3.1).
2. Tabulated lateral design values, Z, are for "reduced body diameter" lag screws (see Appendix Table L.2) inserted in side grain with screw axis perpendicular to wood fibers; screw penetration, p, into the main member equal to 8D; dowel bearing strengths, F_{\perp} , of 61,850 psi for ASTM A653, Grade 33 steel and 87,000 psi for ASTM A36 steel and screw bending yield strengths, F_{yb} , of 70,000 psi for D = 1/4", 60,000 psi for D = 5/16", and 45,000 psi for D ≥ 3/8".
3. Where the lag screw penetration, p, is less than 8D but not less than 4D, tabulated lateral design values, Z, shall be multiplied by p/8D or lateral design values shall be calculated using the provisions of 12.3 for the reduced penetration.
4. The length of lag screw penetration, p, not including the length of the tapered tip, E (see Appendix Table L.2), of the lag screw into the main member shall not be less than 4D. See 12.1.4.6 for minimum length of penetration, p_{min} .



To determine the minimum required hand-rail connections, with a pre-manufactured hand-rail system provided by others. Our scope is limited to assess the minimum connection requirements of the hand-rail system as listed below. Our assumptions are that the base-plates, welds and metal member properties of the pre-manufactured complete system are sufficient in strength to support the code prescribed design loads, for which our design have been provided to comply with.

We have analyzed and verified the minimum connection requirements, for the following conditions:

- Wall connection (sloping wall @ stair)
Result: minimum (2) ¼" DIA x 3" SDS screws to a minimum of (1) support studs at each connection
- Base-plate connection (vertical post application, typical)
Result: The base-plate column connection to have a minimum of (4) 3/8" x 4 ½ lag-screws into full width support member/beams below
- Wall connection (horizontal typical application)
Result: (2) ¼" DIA x 3" SDS screws to a minimum of (2) support studs at each connection

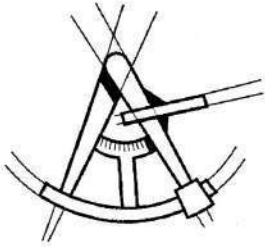

PROJECT

SUBJECT

BY MRT, P.E.

DATE 12/4/2017

CALCULATIONS

CASE 1: SLOPING HAND-RAIL @ WALL / STAIR

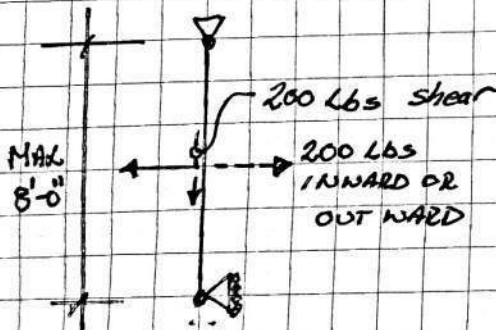
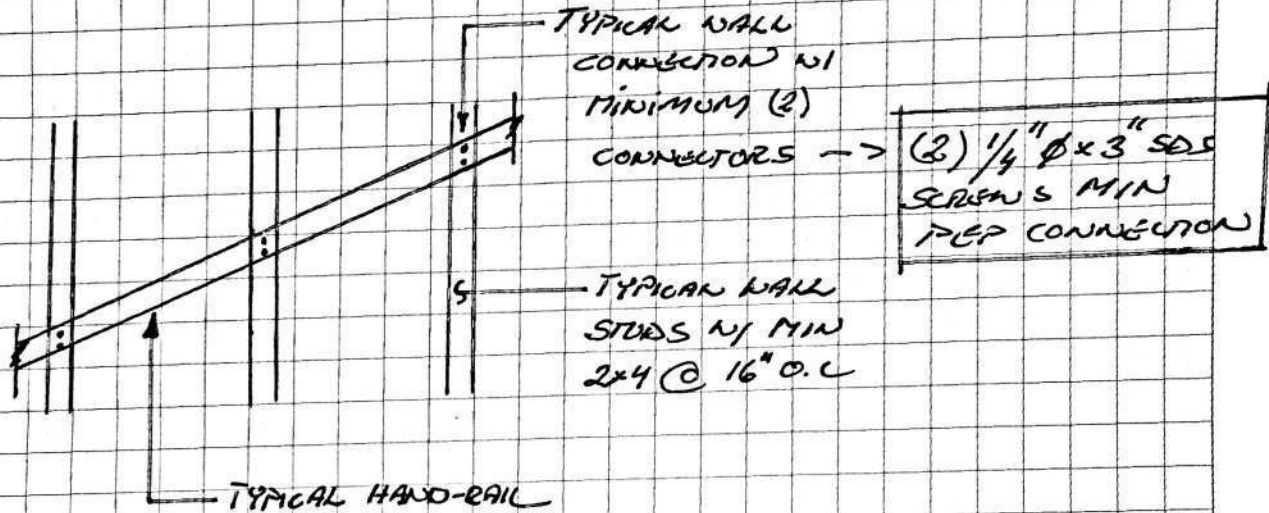

→ SEE ATTACHED CALCULATION OF STUD MEMBER ANALYSIS

$$V = \text{shear capacity } (C_p = C_c = 1.0, C = 4.0, C_g = 0.9)$$

$$V = C_D \times 100 \text{ lbs} = 1.6 \times 100 \text{ lbs} \times 1.0 \times 0.9 \approx 160 \text{ lbs}$$

1/4" φ w/ 2x

$$V_{(2) 1/4" \phi \text{ LAGS MIN INTO 2x HF \#2 OR BETTER}} = 2 \times 160 = 320 \text{ lbs}$$

200 lbs demand < 320 lbs capacity



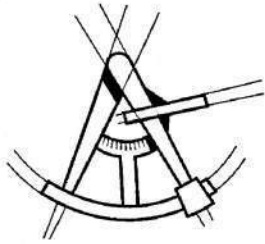

LONGITUDE
ONE TWENTY^o
ENGINEERING & DESIGN

PROJECT _____

SUBJECT _____

BY MRT, P.E.

DATE 12/4/2017

COURT. CASE 1: SLOPING HAND-RAIL @ WALL/STAIR

$W = \text{WITHDRANAL CAPACITY } (C = C = C = 1.0) = 179 \text{ lbs/inch}$

$W_{CP} = 1.6 \times 440 \text{ lbs per screw/LAG} = 179 \text{ lbs} \times 2\frac{1}{2}'' \approx 446 \text{ lbs}$

$W(2) \frac{1}{4}'' \text{ LAGS} \times 3'' \text{ MIN} = 2 \times 440 \text{ lbs} \times 1.6 = 1,408 \text{ lbs}$

PER $\frac{1}{4}''$ LAG $\times 3''$

200 lbs WITHDRANAL DEMAND < 1,408 lbs CAPACITY ✓

CASE 2: BASE PLATE CONNECTION

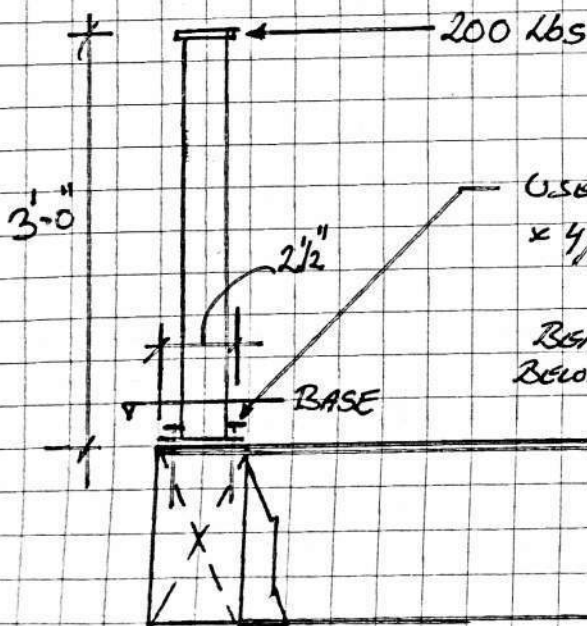

$M = \frac{200 \text{ lbs} \times 36''}{2\frac{1}{2}''} = 2,880 \text{ lbs}$

WITHDRANAL CAPACITY

$W(1) \frac{1}{4}'' \times 4\frac{1}{2}'' \text{ LAG} - 2\frac{1}{2}'' \text{ SCREENS} = 179 \text{ lbs/inch}$

$W = 179 \text{ lbs} \times 4'' \times 1.6 (2 \times \frac{1}{4}'' \phi \times 4\frac{1}{2}'' \text{ LAGS}) = 1,145 \text{ lbs}$

"NOT WORKING" PER $\frac{1}{4}''$ LAG $\times 4\frac{1}{2}''$

$W(2) \frac{1}{4}'' \times 4\frac{1}{2}'' \times 2 = 1,145 \text{ lbs}$
 $W(2) \frac{3}{8}'' \times 4\frac{1}{2}'' \times 2 = 243 \times 4'' \times 2 \times 1.6 = 3,110$

2,880 lbs demand < 3,110 CAPACITY ✓



Company:	L120 Engineering & Design	Date:	5/3/2018
Engineer:	MRT	Page:	1/5
Project:	Hand-rail calculation		
Address:			
Phone:			
E-mail:			

1. Project information

Customer company:
Customer contact name:
Customer e-mail:
Comment:

Project description:
Location:
Fastening description:

2. Input Data & Anchor Parameters

General

Design method: ACI 318-14
Units: Imperial units

Anchor Information:

Anchor type: Concrete screw
Material: Carbon Steel
Diameter (inch): 0.375
Nominal Embedment depth (inch): 3.250
Effective Embedment depth, h_{ef} (inch): 2.400
Code report: ICC-ES ESR-2713
Anchor category: 1
Anchor ductility: No
 h_{min} (inch): 5.00
 C_{ac} (inch): 3.63
 C_{min} (inch): 1.75
 S_{min} (inch): 3.00

Base Material

Concrete: Normal-weight
Concrete thickness, h (inch): 6.00
State: Cracked
Compressive strength, f_c (psi): 2500
 $\Psi_{c,v}$: 1.0
Reinforcement condition: B tension, B shear
Supplemental reinforcement: Not applicable
Reinforcement provided at corners: No
Ignore concrete breakout in tension: No
Ignore concrete breakout in shear: No
Ignore 6do requirement: Not applicable
Build-up grout pad: No

Base Plate

Length x Width x Thickness (inch): 6.00 x 6.00 x 0.25

Load and Geometry

Load factor source: ACI 318 Section 5.3
Load combination: $U = 1.2(D + F) + 1.6(L) + 0.5(L_r \text{ or } S \text{ or } R)$
Seismic design: No
Anchors subjected to sustained tension: Not applicable
Apply entire shear load at front row: No
Anchors only resisting wind and/or seismic loads: No

<Figure 1>

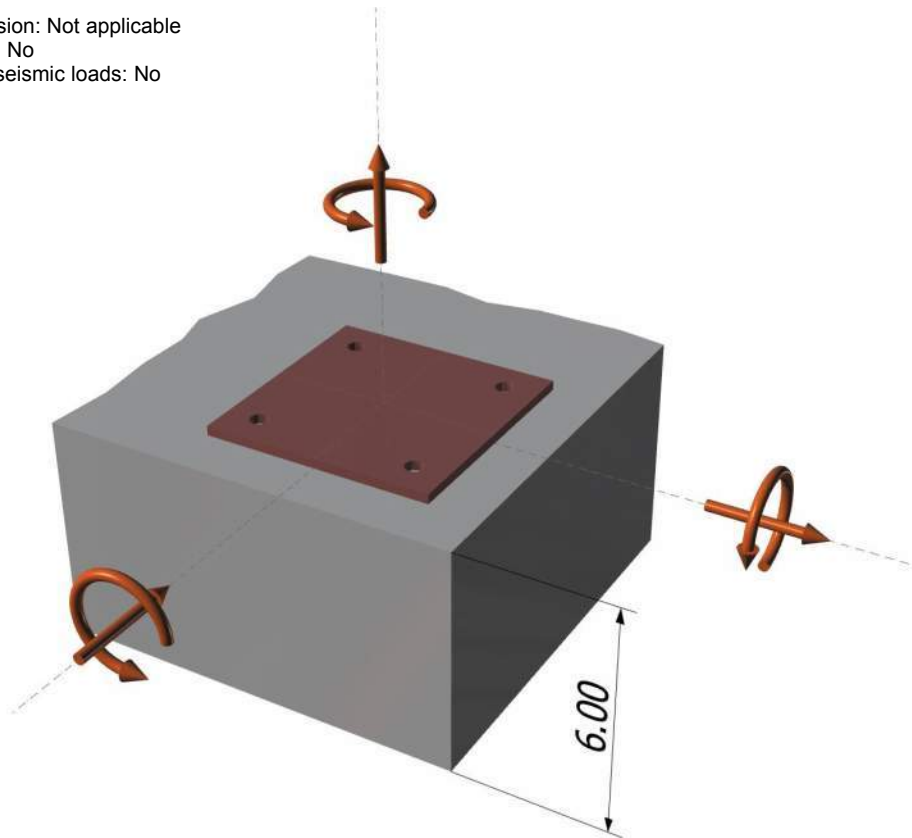



Company:	L120 Engineering & Design	Date:	5/3/2018
Engineer:	MRT	Page:	2/5
Project:	Hand-rail calculation		
Address:			
Phone:			
E-mail:			

<Figure 2>

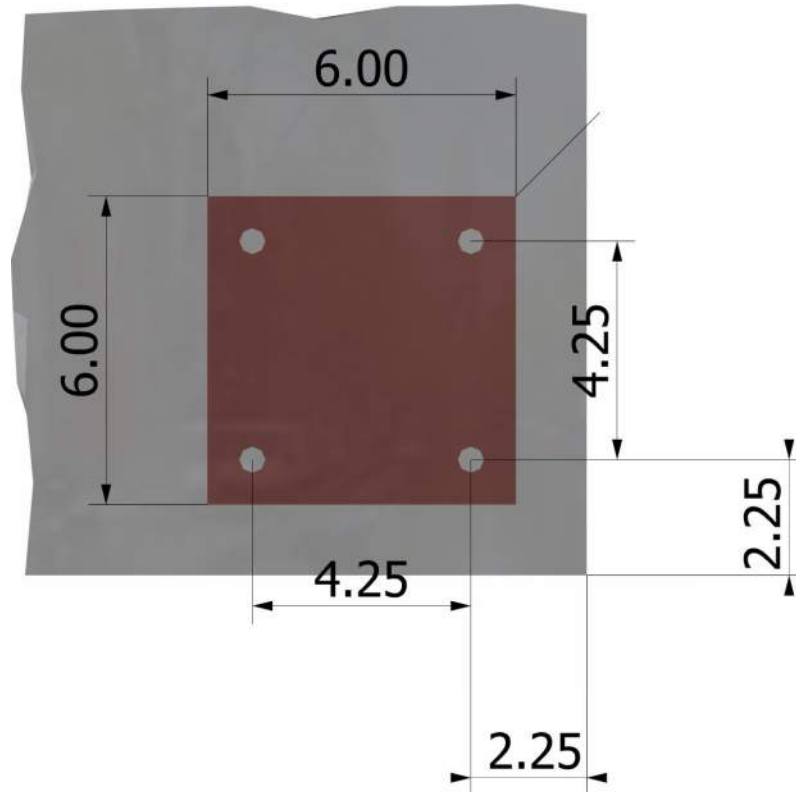

Recommended Anchor

Anchor Name: Titen HD® - 3/8"Ø Titen HD, hnom:3.25" (83mm)
Code Report: ICC-ES ESR-2713





Company:	L120 Engineering & Design	Date:	5/3/2018
Engineer:	MRT	Page:	3/5
Project:	Hand-rail calculation		
Address:			
Phone:			
E-mail:			

3. Resulting Anchor Forces

Anchor	Tension load, N_{ua} (lb)	Shear load x, V_{uax} (lb)	Shear load y, V_{uay} (lb)	Shear load combined, $\sqrt{(V_{uax})^2 + (V_{uay})^2}$ (lb)
1	1250.4	-80.0	0.0	80.0
2	1250.4	-80.0	0.0	80.0
3	0.0	-80.0	0.0	80.0
4	0.0	-80.0	0.0	80.0
Sum	2500.7	-320.0	0.0	320.0

Maximum concrete compression strain (%): 0.12
 Maximum concrete compression stress (psi): 538
 Resultant tension force (lb): 2501
 Resultant compression force (lb): 2501
 Eccentricity of resultant tension forces in x-axis, e'_{Nx} (inch): 0.00
 Eccentricity of resultant tension forces in y-axis, e'_{Ny} (inch): 0.00
 Eccentricity of resultant shear forces in x-axis, e'_{Vx} (inch): 0.00
 Eccentricity of resultant shear forces in y-axis, e'_{Vy} (inch): 0.00

<Figure 3>

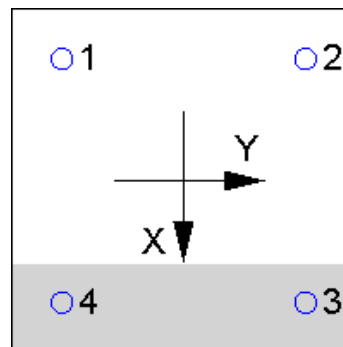

4. Steel Strength of Anchor in Tension (Sec. 17.4.1)

N_{sa} (lb)	ϕ	ϕN_{sa} (lb)
10890	0.65	7079

5. Concrete Breakout Strength of Anchor in Tension (Sec. 17.4.2)

$$N_b = k_c \lambda_a \sqrt{f_c} h_{ef}^{1.5} \text{ (Eq. 17.4.2.2a)}$$

k_c	λ_a	f_c (psi)	h_{ef} (in)	N_b (lb)
17.0	1.00	2500	2.400	3160

$$\phi N_{cbg} = \phi (A_{Nc} / A_{Nco}) \Psi_{ec,N} \Psi_{ed,N} \Psi_{c,N} \Psi_{cp,N} N_b \text{ (Sec. 17.3.1 & Eq. 17.4.2.1b)}$$

A_{Nc} (in ²)	A_{Nco} (in ²)	$c_{a,min}$ (in)	$\Psi_{ec,N}$	$\Psi_{ed,N}$	$\Psi_{c,N}$	$\Psi_{cp,N}$	N_b (lb)	ϕ	ϕN_{cbg} (lb)
72.72	51.84	2.25	1.000	0.888	1.00	1.000	3160	0.65	2557

6. Pullout Strength of Anchor in Tension (Sec. 17.4.3)

$$\phi N_{pn} = \phi \Psi_{c,P} \lambda_a N_p (f_c / 2,500)^n \text{ (Sec. 17.3.1, Eq. 17.4.3.1 & Code Report)}$$

$\Psi_{c,P}$	λ_a	N_p (lb)	f_c (psi)	n	ϕ	ϕN_{pn} (lb)
1.0	1.00	2700	2500	0.50	0.65	1755



Company:	L120 Engineering & Design	Date:	5/3/2018
Engineer:	MRT	Page:	4/5
Project:	Hand-rail calculation		
Address:			
Phone:			
E-mail:			

8. Steel Strength of Anchor in Shear (Sec. 17.5.1)

V_{sa} (lb)	ϕ_{grout}	ϕ	$\phi_{grout}\phi V_{sa}$ (lb)
4460	1.0	0.60	2676

9. Concrete Breakout Strength of Anchor in Shear (Sec. 17.5.2)

Shear parallel to edge in x-direction:

$$V_{by} = \min[7(l_e/d_a)^{0.2}\sqrt{d_a}\lambda_a\sqrt{f_c}c_{a1}^{1.5}; 9\lambda_a\sqrt{f_c}c_{a1}^{1.5}] \text{ (Eq. 17.5.2.2a \& Eq. 17.5.2.2b)}$$

l_e (in)	d_a (in)	λ_a	f_c (psi)	c_{a1} (in)	V_{by} (lb)
2.40	0.375	1.00	2500	2.25	1049

$$\phi V_{cbgx} = \phi (2)(A_{Vc}/A_{Vco})\Psi_{ec,V}\Psi_{ed,V}\Psi_{c,V}\Psi_{h,V}V_{by} \text{ (Sec. 17.3.1, 17.5.2.1(c) \& Eq. 17.5.2.1b)}$$

A_{Vc} (in ²)	A_{Vco} (in ²)	$\Psi_{ec,V}$	$\Psi_{ed,V}$	$\Psi_{c,V}$	$\Psi_{h,V}$	V_{by} (lb)	ϕ	ϕV_{cbgx} (lb)
33.33	22.78	1.000	1.000	1.000	1.000	1049	0.70	2148

10. Concrete Pryout Strength of Anchor in Shear (Sec. 17.5.3)

$$\phi V_{cpq} = \phi k_{cp}N_{cbg} = \phi k_{cp}(A_{Nc}/A_{Nco})\Psi_{ec,N}\Psi_{ed,N}\Psi_{c,N}\Psi_{cp,NN}N_b \text{ (Sec. 17.3.1 \& Eq. 17.5.3.1b)}$$

k_{cp}	A_{Nc} (in ²)	A_{Nco} (in ²)	$\Psi_{ec,N}$	$\Psi_{ed,N}$	$\Psi_{c,N}$	$\Psi_{cp,NN}$	N_b (lb)	ϕ	ϕV_{cpq} (lb)
1.0	102.01	51.84	1.000	0.888	1.000	1.000	3160	0.70	3863

11. Results

Interaction of Tensile and Shear Forces (Sec. 17.6.)

Tension	Factored Load, N_{ua} (lb)	Design Strength, ϕN_n (lb)	Ratio	Status	
Steel	1250	7079	0.18	Pass	
Concrete breakout	2501	2557	0.98	Pass (Governs)	
Pullout	1250	1755	0.71	Pass	
Shear	Factored Load, V_{ua} (lb)	Design Strength, ϕV_n (lb)	Ratio	Status	
Steel	80	2676	0.03	Pass	
Concrete breakout y+	160	2148	0.07	Pass	
Pryout	320	3863	0.08	Pass (Governs)	
Interaction check	$N_{ua}/\phi N_n$	$V_{ua}/\phi V_n$	Combined Ratio	Permissible	Status
Sec. 17.6..1	0.98	0.00	97.8 %	1.0	Pass

3/8"Ø Titen HD, hnom:3.25" (83mm) meets the selected design criteria.



Anchor Designer™
Software
Version 2.5.6582.0

Company:	L120 Engineering & Design	Date:	5/3/2018
Engineer:	MRT	Page:	5/5
Project:	Hand-rail calculation		
Address:			
Phone:			
E-mail:			

12. Warnings

- Minimum spacing and edge distance requirement of 6da per ACI 318 Sections 17.7.1 and 17.7.2 for torqued cast-in-place anchor is waived per designer option.
- Designer must exercise own judgement to determine if this design is suitable.
- Refer to manufacturer's product literature for hole cleaning and installation instructions.

Project:

Location: Single 2x4 stud (staircase)
Multi-Loaded Multi-Span Beam
[2015 International Building Code(2015 NDS)]
1.5 IN x 3.5 IN x 8.0 FT
#2 - Hem-Fir - Dry Use
Section Adequate By: 0.8%
Controlling Factor: Deflection

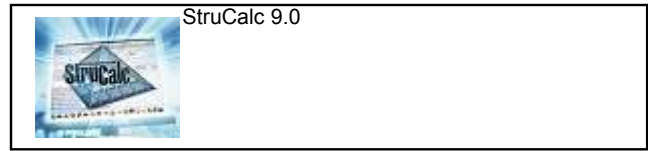

StruCalc Version 10.0.1.6

12/4/2017 4:33:33 PM

DEFLECTIONS		Center
Live Load	0.53	IN L/181
Dead Load	0.01	in
Total Load	0.54	IN L/177
Live Load Deflection Criteria: L/180		Total Load Deflection Criteria: L/120

REACTIONS		
	A	B
Live Load	100 lb	100 lb
Dead Load	4 lb	4 lb
Total Load	104 lb	104 lb
Bearing Length	0.17 in	0.17 in

BEAM DATA		Center
Span Length	8	ft
Unbraced Length-Top	0	ft
Unbraced Length-Bottom	8	ft
Live Load Duration Factor	1.60	
Notch Depth	0.00	

MATERIAL PROPERTIES			
#2 - Hem-Fir			
	Base Values		Adjusted
Bending Stress:	Fb =	850 psi	Fb' = 2040 psi
		Cd=1.60 CF=1.50	
Shear Stress:	Fv =	150 psi	Fv' = 240 psi
		Cd=1.60	
Modulus of Elasticity:	E =	1300 ksi	E' = 1300 ksi
Comp. \perp to Grain:	Fc - \perp =	405 psi	Fc - \perp ' = 405 psi

Controlling Moment: 408 ft-lb
4.0 Ft from left support of span 2 (Center Span)
Created by combining all dead loads and live loads on span(s) 2

Controlling Shear: -104 lb
At right support of span 2 (Center Span)
Created by combining all dead loads and live loads on span(s) 2

Comparisons with required sections:	Req'd	Provided
Section Modulus:	2.4 in ³	3.06 in ³
Area (Shear):	0.65 in ²	5.25 in ²
Moment of Inertia (deflection):	5.32 in ⁴	5.36 in ⁴
Moment:	408 ft-lb	521 ft-lb
Shear:	-104 lb	840 lb

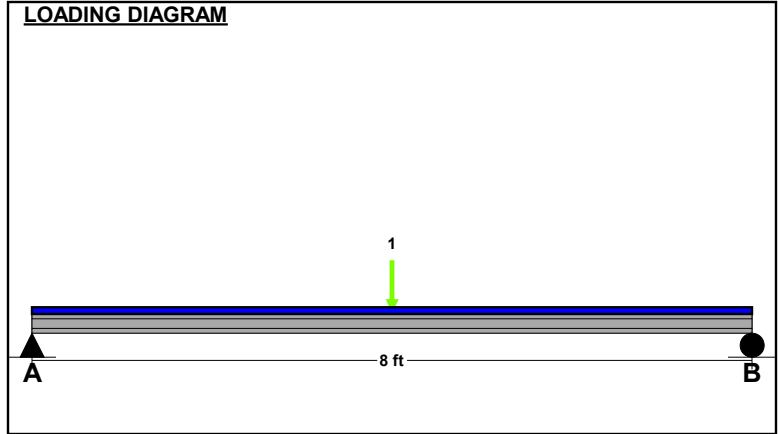

UNIFORM LOADS		Center
Uniform Live Load	0	plf
Uniform Dead Load	0	plf
Beam Self Weight	1	plf
Total Uniform Load	1	plf

POINT LOADS - CENTER SPAN	
Load Number	One
Live Load	200 lb
Dead Load	0 lb
Location	4 ft

Project:

Location: Single 2x6 stud (staircase)
Multi-Loaded Multi-Span Beam
[2015 International Building Code(2015 NDS)]
1.5 IN x 5.5 IN x 9.0 FT
#2 - Hem-Fir - Dry Use
Section Adequate By: 139.3%
Controlling Factor: Moment

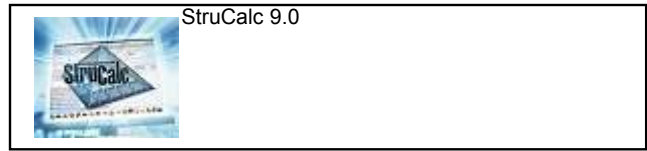

StruCalc Version 10.0.1.6

12/4/2017 4:34:53 PM

DEFLECTIONS		Center
Live Load	0.19	IN L/556
Dead Load	0.01	in
Total Load	0.20	IN L/533
Live Load Deflection Criteria: L/180		Total Load Deflection Criteria: L/120

REACTIONS		
	A	B
Live Load	100 lb	100 lb
Dead Load	7 lb	7 lb
Total Load	107 lb	107 lb
Bearing Length	0.18 in	0.18 in

BEAM DATA		Center
Span Length	9	ft
Unbraced Length-Top	0	ft
Unbraced Length-Bottom	9	ft
Live Load Duration Factor	1.60	
Notch Depth	0.00	

MATERIAL PROPERTIES

#2 - Hem-Fir

	Base Values	Adjusted
Bending Stress:	Fb = 850 psi Cd=1.60 CF=1.30	Fb' = 1768 psi
Shear Stress:	Fv = 150 psi Cd=1.60	Fv' = 240 psi
Modulus of Elasticity:	E = 1300 ksi	E' = 1300 ksi
Comp. \perp to Grain:	Fc \perp = 405 psi	Fc \perp ' = 405 psi

Controlling Moment: 466 ft-lb
4.5 Ft from left support of span 2 (Center Span)
Created by combining all dead loads and live loads on span(s) 2
Controlling Shear: -107 lb
At right support of span 2 (Center Span)
Created by combining all dead loads and live loads on span(s) 2

Comparisons with required sections:	Req'd	Provided
Section Modulus:	3.16 in ³	7.56 in ³
Area (Shear):	0.67 in ²	8.25 in ²
Moment of Inertia (deflection):	6.73 in ⁴	20.8 in ⁴
Moment:	466 ft-lb	1114 ft-lb
Shear:	-107 lb	1320 lb

LOADING DIAGRAM

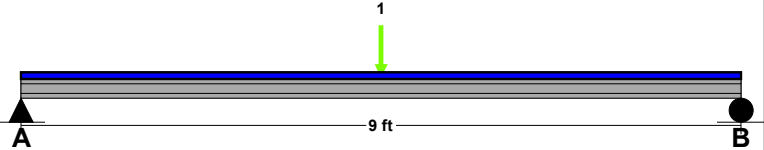

UNIFORM LOADS

	Center
Uniform Live Load	0 plf
Uniform Dead Load	0 plf
Beam Self Weight	2 plf
Total Uniform Load	2 plf

POINT LOADS - CENTER SPAN

Load Number	One
Live Load	200 lb
Dead Load	0 lb
Location	4.5 ft

Project:

Location: Double 2x4 stud (flat orientation connection/top)
Multi-Loaded Multi-Span Beam
[2015 International Building Code(2015 NDS)]
(2) 1.5 IN x 3.5 IN x 8.0 FT
#2 - Hem-Fir - Dry Use
Section Adequate By: 101.6%
Controlling Factor: Deflection

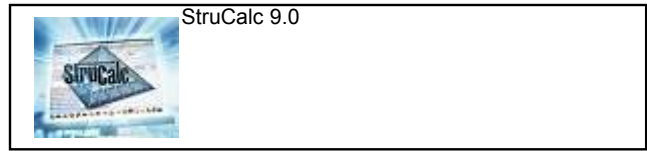

page
of

StruCalc Version 10.0.1.6

12/4/2017 4:38:42 PM

DEFLECTIONS		Center
Live Load	0.26	IN L/363
Dead Load	0.01	in
Total Load	0.28	IN L/346
Live Load Deflection Criteria: L/180		Total Load Deflection Criteria: L/120

REACTIONS		
	A	B
Live Load	100 lb	100 lb
Dead Load	8 lb	8 lb
Total Load	108 lb	108 lb
Bearing Length	0.09 in	0.09 in

BEAM DATA		Center
Span Length	8	ft
Unbraced Length-Top	0	ft
Unbraced Length-Bottom	8	ft
Live Load Duration Factor	1.60	
Notch Depth	0.00	

MATERIAL PROPERTIES			
#2 - Hem-Fir			
	Base Values	Adjusted	
Bending Stress:	Fb = 850 psi	Fb' = 2040 psi	
	Cd=1.60 CF=1.50		
Shear Stress:	Fv = 150 psi	Fv' = 240 psi	
	Cd=1.60		
Modulus of Elasticity:	E = 1300 ksi	E' = 1300 ksi	
Comp. \perp to Grain:	Fc - \perp = 405 psi	Fc - \perp ' = 405 psi	

Controlling Moment: 416 ft-lb
4.0 Ft from left support of span 2 (Center Span)
Created by combining all dead loads and live loads on span(s) 2

Controlling Shear: 108 lb
At left support of span 2 (Center Span)
Created by combining all dead loads and live loads on span(s) 2

Comparisons with required sections:	Req'd	Provided
Section Modulus:	2.45 in ³	6.13 in ³
Area (Shear):	0.67 in ²	10.5 in ²
Moment of Inertia (deflection):	5.32 in ⁴	10.72 in ⁴
Moment:	416 ft-lb	1041 ft-lb
Shear:	108 lb	1680 lb

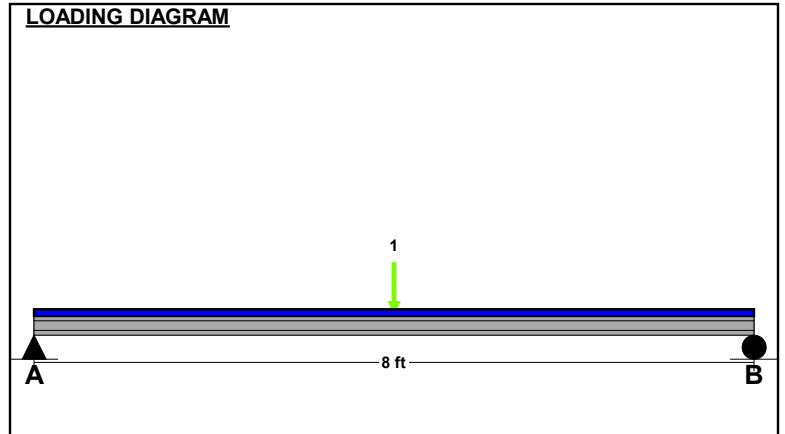

UNIFORM LOADS		Center
Uniform Live Load	0	plf
Uniform Dead Load	0	plf
Beam Self Weight	2	plf
Total Uniform Load	2	plf

POINT LOADS - CENTER SPAN	
Load Number	One
Live Load	200 lb
Dead Load	0 lb
Location	4 ft



Balloon Framed stud calculations



DATE:	3/3/2021	COMPANY:	L120 Engineering & Design, LLC
VITRUVIUS BUILD:	StruCalc	DESIGNED BY:	Mans Thurfjell
CUSTOMER:		REVIEWED BY:	Mans Thurfjell
PROJECT LOCATION:			
LEVEL:	Roof	LOADING:	ASD
LOCATION:	2x6 Balloon Frame (12" o.c.) (wind load Code for application)		2018 International Building Code
TYPE:	COLUMN	NDS:	2018 NDS
MATERIAL:	SOLID SAWN		
Hem-Fir	No. 2	(1) 1.5 X 5.5	DRY



COLUMN PROPERTIES

Start (ft): 0 End (ft): 17.25 Member Slope: 0/12 Actual Length (ft): 17.25

Area	I _x	I _y	BSW	Lams	G	K _{cr}
(in ²)	(in ⁴)	(in ⁴)	(lbf/ft)			Creep Factor
8.25	20.8	1.55	1.63	1	0.43	1

STRENGTH PROPERTIES

	F _b (psi)	F _t (psi)	F _v (psi)	F _c (psi)	F _{c⊥} (psi)	E (psi) x10 ³	E _{min} (psi) x10 ³
Base Values	850	525	150	1300	405	1300	470
Adjusted Values	1105	682	150	1430	405	1300	470
C _M	1	1	1	1	1	1	1
C _T	1	1	1	1	1	1	1
C _i	1	1	1	1	1	1	1
C _F	1.3	1.3	1	1.1	1	1	1

Bending Adjustment Factors C_{fu} = 1 C_r = 1

COLUMN DATA

Span	Length (ft)	Unbraced Length (ft)		Column End					
		X	Y	Offset	CP	Ke(X Axis)	Ke(Y Axis)	KeL/d (X Axis)	KeL/d (Y Axis)
1	17.25	17.25	1	0	0.18	1.00	1.00	37.64	8

PASS-FAIL

	PASS/FAIL	MAGNITUDE	STRENGTH	LOCATION (ft)	LOAD COMBO	DURATION FACTOR CD
Shear Stress Y (psi)	PASS (89.5%)	15.7	150.0	17.25	D+L	1
Bending Stress Y (psi)	PASS (46.3%)	590.2	1099.4	8.62	D+L	1
Deflection (in)	PASS (35.9%)	0.737 (=L/281)	1.150 (=L/180)	8.62	L	
Compressive Stress (psi)	PASS (61.6%)	100.4	261.1	0	D+L	1
Bearing Stress (psi)	PASS (98.9%)	16.4	1430.0	0	D+L	1
Bending-Compression (Unit)	PASS (1.6%)	0.98	1.00	8.62	D+L	1

REACTIONS

Units for V: lbf Units for M: lbf-ft

Z axis	DEAD	LIVE	LIVE ROOF	SNOW	WIND +	WIND -	SEISMIC +	SEISMIC -	ICE	RAIN	EARTH
A	328	500	0	0	0	0	0	0	0	0	0
B	0	0	0	0	0	0	0	0	0	0	0
Y axis											
A	0	86	0	0	0	0	0	0	0	0	0
B	0	86	0	0	0	0	0	0	0	0	0

Reaction Location

A

B

LOAD LIST

Type	Left Magnitude	Right Magnitude	Load Start (ft)	Load End (ft)	Load Type	Direction
Uniform (lb/ft)	10	10	0	17.25	Live	Y
Point (lb)	-500	-	17.25	-	Live	Z
Point (lb)	-300	-	17.25	-	Dead	Z
Self Weight (lb/ft)	1.63	1.63	0	17.25	Dead	Z

NOTES

PASS

DATE:	3/3/2021	COMPANY:	L120 Engineering & Design, LLC
VITRUVIUS BUILD:	StruCalc	DESIGNED BY:	Mans Thurfjell
CUSTOMER:		REVIEWED BY:	Mans Thurfjell
PROJECT LOCATION:			
LEVEL:	Roof	LOADING:	ASD
LOCATION:	1.75x5.5 LSL Balloon Frame (@12") (wind load)	CODE:	2018 International Building Code
TYPE:	COLUMN	NDS:	2018 NDS
MATERIAL:	STRUCTURAL COMPOSITE LUMBER		
Weyerhaeuser	1.55E TimberStrand LSL	(1) 1.75 X 5.5	DRY



COLUMN PROPERTIES

Start (ft): 0 End (ft): 17.25 Member Slope: 0/12 Actual Length (ft): 17.25

Area	I _x	I _y	BSW	Lams	C _{fn}	K _{cr}
(in ²)	(in ⁴)	(in ⁴)	(lb/ft)			Creep Factor
9.62	24.26	2.46	3.01	1	10.87	1

STRENGTH PROPERTIES

	F _b (psi)	F _t (psi)	F _v (psi)	F _c (psi)	F _{c⊥} (psi)	E (psi) x10 ³	E _{min} (psi) x10 ³
Base Values	2325	1290	310	2170	900	1550	787.815
Adjusted Values	2325	1290	310	2170	900	1550	788
C _M	1	1	1	1	1	1	1
C _T	1	1	1	1	1	1	1
Bending Adjustment Factors	C _V = 1.07 C _r = 1 Volume factor is applied on a load combination basis And is Not reflected in the adjusted values						

COLUMN DATA

Span	Length (ft)	Unbraced Length (ft)		Column End		Ke(X Axis)	Ke(Y Axis)	KeL/d (X Axis)	KeL/d (Y Axis)
		X	Y	Offset	CP				
1	17.25	17.25	1	0	0.21	1.00	1.00	37.64	6.86

PASS-FAIL

	PASS/FAIL	MAGNITUDE	STRENGTH	LOCATION (ft)	LOAD COMBO	DURATION FACTOR CD
Shear Stress Y (psi)	PASS (95.7%)	13.4	310.0	17.25	D+L	1
Bending Stress Y (psi)	PASS (79.7%)	505.9	2486.4	8.62	D+L	1
Deflection (in)	PASS (53.9%)	0.530 (=L/391)	1.150 (=L/180)	8.62	L	
Compressive Stress (psi)	PASS (40.5%)	265.1	445.7	0	D+L	1
Bearing Stress (psi)	PASS (99.4%)	14.1	2170.0	0	D+L	1
Bending-Compression (Unit)	PASS (17.5%)	0.82	1.00	8.45	D+L	1

REACTIONS

Z axis	Units for V: lbf			Units for M: lbf-ft			WIND +	WIND -	SEISMIC +	SEISMIC -	ICE	RAIN	EARTH
	DEAD	LIVE	LIVE ROOF	SNOW									
A	1052	1500	0	0	0	0	0	0	0	0	0	0	0
B	0	0	0	0	0	0	0	0	0	0	0	0	0
Y axis													
A	0	86	0	0	0	0	0	0	0	0	0	0	0
B	0	86	0	0	0	0	0	0	0	0	0	0	0

Reaction Location

A

B

LOAD LIST

Type	Left Magnitude	Right Magnitude	Load Start (ft)	Load End (ft)	Load Type	Direction
Point (lbf)	-1500	-	17.25	-	Live	Z
Point (lbf)	-1000	-	17.25	-	Dead	Z
Uniform (lbf/ft)	10	10	0	17.25	Live	Y
Self Weight (lbf/ft)	3.01	3.01	0	17.25	Dead	Z

NOTES



DATE:	3/3/2021	COMPANY:	L120 Engineering & Design, LLC
VITRUVIUS BUILD:	StruCalc	DESIGNED BY:	Mans Thurfjell
CUSTOMER:		REVIEWED BY:	Mans Thurfjell
PROJECT LOCATION:			
LEVEL:	Roof	LOADING:	ASD
LOCATION:	2x6 Balloon Frame (8" o.c.) (Wind load Code: applicable to International Building Code)		
TYPE:	COLUMN	NDS:	2018 NDS
MATERIAL:	SOLID SAWN		
Hem-Fir	No. 2	(1) 1.5 X 5.5	DRY



COLUMN PROPERTIES

Start (ft): 0 End (ft): 17.25 Member Slope: 0/12 Actual Length (ft): 17.25

Area	I _x	I _y	BSW	Lams	G	K _{cr}
(in ²)	(in ⁴)	(in ⁴)	(lbf/ft)			Creep Factor
8.25	20.8	1.55	1.63	1	0.43	1

STRENGTH PROPERTIES

	F _b (psi)	F _t (psi)	F _v (psi)	F _c (psi)	F _{c⊥} (psi)	E (psi) x10 ³	E _{min} (psi) x10 ³
Base Values	850	525	150	1300	405	1300	470
Adjusted Values	1105	682	150	1430	405	1300	470
C _M	1	1	1	1	1	1	1
C _T	1	1	1	1	1	1	1
C _i	1	1	1	1	1	1	1
C _F	1.3	1.3	1	1.1	1	1	1

Bending Adjustment Factors C_{fu} = 1 C_r = 1

COLUMN DATA

Span	Length (ft)	Unbraced Length (ft)		Column End					
		X	Y	Offset	CP	Ke(X Axis)	Ke(Y Axis)	KeL/d (X Axis)	KeL/d (Y Axis)
1	17.25	17.25	1	0	0.18	1.00	1.00	37.64	8

PASS-FAIL

	PASS/FAIL	MAGNITUDE	STRENGTH	LOCATION (ft)	LOAD COMBO	DURATION FACTOR CD
Shear Stress Y (psi)	PASS (92.7%)	11.0	150.0	17.25	D+L	1
Bending Stress Y (psi)	PASS (62.4%)	413.1	1099.4	8.62	D+L	1
Deflection (in)	PASS (55.1%)	0.516 (=L/401)	1.150 (=L/180)	8.62	L	
Compressive Stress (psi)	PASS (49.9%)	130.7	261.1	0	D+L	1
Bearing Stress (psi)	PASS (99.2%)	11.5	1430.0	0	D+L	1
Bending-Compression (Unit)	PASS (4.3%)	0.96	1.00	8.45	D+L	1

REACTIONS

Units for V: lbf Units for M: lbf-ft

Z axis	DEAD	LIVE	LIVE ROOF	SNOW	WIND +	WIND -	SEISMIC +	SEISMIC -	ICE	RAIN	EARTH
A	528	550	0	0	0	0	0	0	0	0	0
B	0	0	0	0	0	0	0	0	0	0	0
Y axis											
A	0	60	0	0	0	0	0	0	0	0	0
B	0	60	0	0	0	0	0	0	0	0	0

Reaction Location

A

B

LOAD LIST

Type	Left Magnitude	Right Magnitude	Load Start (ft)	Load End (ft)	Load Type	Direction
Point (lbf)	-550	-	17.25	-	Live	Z
Point (lbf)	-500	-	17.25	-	Dead	Z
Uniform (lbf/ft)	7	7	0	17.25	Live	Y
Self Weight (lbf/ft)	1.63	1.63	0	17.25	Dead	Z

NOTES

PASS

DATE:	3/3/2021	COMPANY:	L120 Engineering & Design, LLC
VITRUVIUS BUILD:	StruCalc	DESIGNED BY:	Mans Thurfjell
CUSTOMER:		REVIEWED BY:	Mans Thurfjell
PROJECT LOCATION:			
LEVEL:	Roof	LOADING:	ASD
LOCATION:	175x5.5 LSL Balloon Frame (@ 8") (Wind Load factored per International Building Code)		
TYPE:	COLUMN	NDS:	2018 NDS
MATERIAL:	STRUCTURAL COMPOSITE LUMBER		
Weyerhaeuser	1.55E TimberStrand LSL	(1) 1.75 X 5.5	DRY



COLUMN PROPERTIES

Start (ft): 0 End (ft): 17.25 Member Slope: 0/12 Actual Length (ft): 17.25

Area	I _x	I _y	BSW	Lams	C _{fn}	K _{cr}
(in ²)	(in ⁴)	(in ⁴)	(lb/ft)			Creep Factor
9.62	24.26	2.46	3.01	1	10.87	1

STRENGTH PROPERTIES

	F _b (psi)	F _t (psi)	F _v (psi)	F _c (psi)	F _{c⊥} (psi)	E (psi) x10 ³	E _{min} (psi) x10 ³
Base Values	2325	1290	310	2170	900	1550	787.815
Adjusted Values	2325	1290	310	2170	900	1550	788
C _M	1	1	1	1	1	1	1
C _T	1	1	1	1	1	1	1
Bending Adjustment Factors	C _V = 1.07 C _r = 1 Volume factor is applied on a load combination basis And is Not reflected in the adjusted values						

COLUMN DATA

Span	Length (ft)	Unbraced Length (ft)		Column End					
		X	Y	Offset	CP	Ke(X Axis)	Ke(Y Axis)	KeL/d (X Axis)	KeL/d (Y Axis)
1	17.25	17.25	1	0	0.21	1.00	1.00	37.64	6.86

PASS-FAIL

	PASS/FAIL	MAGNITUDE	STRENGTH	LOCATION (ft)	LOAD COMBO	DURATION FACTOR CD
Shear Stress Y (psi)	PASS (97.0%)	9.4	310.0	17.25	D+L	1
Bending Stress Y (psi)	PASS (85.8%)	354.1	2486.4	8.62	D+L	1
Deflection (in)	PASS (67.7%)	0.371 (=L/558)	1.150 (=L/180)	8.62	L	
Compressive Stress (psi)	PASS (28.9%)	317.1	445.7	0	D+L	1
Bearing Stress (psi)	PASS (99.5%)	9.9	2170.0	0	D+L	1
Bending-Compression (Unit)	PASS (4.6%)	0.95	1.00	8.45	D+L	1

REACTIONS

	Units for V: lbf		Units for M: lbf-ft								
Z axis	DEAD	LIVE	LIVE ROOF	SNOW	WIND +	WIND -	SEISMIC +	SEISMIC -	ICE	RAIN	EARTH
A	1052	2000	0	0	0	0	0	0	0	0	0
B	0	0	0	0	0	0	0	0	0	0	0
Y axis											
A	0	60	0	0	0	0	0	0	0	0	0
B	0	60	0	0	0	0	0	0	0	0	0

Reaction Location

A

B

LOAD LIST

Type	Left Magnitude	Right Magnitude	Load Start (ft)	Load End (ft)	Load Type	Direction
Point (lbf)	-1000	-	17.25	-	Dead	Z
Point (lbf)	-2000	-	17.25	-	Live	Z
Uniform (lbf/ft)	7	7	0	17.25	Live	Y
Self Weight (lbf/ft)	3.01	3.01	0	17.25	Dead	Z

NOTES



LONGITUDE
ONE TWENTY°
ENGINEERING & DESIGN

Ledger Calculations



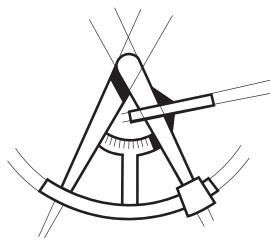

LONGITUDE
ONE TWENTY°
 ENGINEERING & DESIGN

PROJECT NO.	SHEET NO.

PROJECT _____

SUBJECT _____

BY _____ DATE ____ / ____ / ____

Table 12.3.3A Assigned Specific Gravities

Species Combination	Specific ¹ Gravity, G	Species Combinations of MSR and MEL Lumber	Specific ¹ Gravity, G
Alaska Cedar	0.47	Douglas Fir-Larch	
Alaska Hemlock	0.46	E=1,900,000 psi and lower grades of MSR	0.50
Alaska Spruce	0.41	E=2,000,000 psi grades of MSR	0.51
Alaska Yellow Cedar	0.46	E=2,100,000 psi grades of MSR	0.52
Aspen	0.39	E=2,200,000 psi grades of MSR	0.53
Balsam Fir	0.36	E=2,300,000 psi grades of MSR	0.54
BEAMS (DF #2, and Engineered Lumber)		E=2,400,000 psi grades of MSR	0.55
Beech-Birch-Hickory	0.71	Douglas Fir-Larch (North)	
Coast Sitka Spruce	0.39	E=1,900,000 psi and lower grades of MSR and MEL	0.49
Cottonwood	0.41	E=2,000,000 psi to 2,200,000 psi grades of MSR and MEL	0.53
Douglas Fir-Larch	0.50	E=2,300,000 psi and higher grades of MSR and MEL	0.57
Douglas Fir-Larch (North)	0.49	Douglas Fir-Larch (South)	
Douglas Fir-South	0.46	E=1,000,000 psi and higher grades of MSR	0.46
Eastern Hemlock	0.41	Engelmann Spruce-Lodgepole Pine	
Eastern Hemlock-Balsam Fir	0.36	E=1,400,000 psi and lower grades of MSR	0.38
Eastern Hemlock-Tamarack	0.41	E=1,500,000 psi and higher grades of MSR	0.46
Eastern Hemlock-Tamarack (North)	0.47	Hem-Fir	
Eastern Softwoods	0.36	E=1,500,000 psi and lower grades of MSR	0.43
Joists and 2x members (HF #2)		E=1,600,000 psi grades of MSR	0.44
Eastern Spruce	0.41	E=1,700,000 psi grades of MSR	0.45
Eastern White Pine	0.36	E=1,800,000 psi grades of MSR	0.46
Engelmann Spruce-Lodgepole Pine	0.38	E=1,900,000 psi grades of MSR	0.47
Hem-Fir	0.43	E=2,000,000 psi grades of MSR	0.48
Hem-Fir (North)	0.46	E=2,100,000 psi grades of MSR	0.49
Mixed Maple	0.55	E=2,200,000 psi grades of MSR	0.50
Mixed Oak	0.68	E=2,300,000 psi grades of MSR	0.51
Mixed Southern Pine	0.51	E=2,400,000 psi grades of MSR	0.52
Mountain Hemlock	0.47	Hem-Fir (North)	
Northern Pine	0.42	E=1,000,000 psi and higher grades of MSR and MEL	0.46
Northern Red Oak	0.68	Southern Pine	
Northern Species	0.35	E=1,700,000 psi and lower grades of MSR and MEL	0.55
Northern White Cedar	0.31	E=1,800,000 psi and higher grades of MSR and MEL	0.57
Ponderosa Pine	0.43	Spruce-Pine-Fir	
Red Maple	0.58	E=1,700,000 psi and lower grades of MSR and MEL	0.42
Red Oak	0.67	E=1,800,000 psi and 1,900,000 grades of MSR and MEL	0.46
Red Pine	0.44	E=2,000,000 psi and higher grades of MSR and MEL	0.50
Redwood, close grain	0.44	Spruce-Pine-Fir (South)	
Redwood, open grain	0.37	E=1,100,000 psi and lower grades of MSR	0.36
Sitka Spruce	0.43	E=1,200,000 psi to 1,900,000 psi grades of MSR	0.42
Southern Pine	0.55	E=2,000,000 psi and higher grades of MSR	0.50
Spruce-Pine-Fir	0.42	Western Cedars	
Spruce-Pine-Fir (South)	0.36	E=1,000,000 psi and higher grades of MSR	0.36
Western Cedars	0.36	Western Woods	
Western Cedars (North)	0.35	E=1,000,000 psi and higher grades of MSR	0.36
Western Hemlock	0.47		
Western Hemlock (North)	0.46		
Western White Pine	0.40		
Western Woods	0.36		
White Oak	0.73		
Yellow Poplar	0.43		

1. Specific gravity, G, based on weight and volume when oven-dry. Different specific gravities, G, are possible for different grades of MSR and MEL lumber (see Table 4C, Footnote 2).

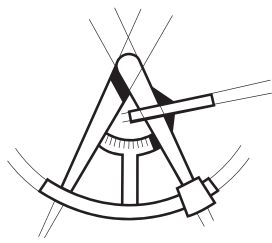

LONGITUDE
ONE TWENTY^o
 ENGINEERING & DESIGN

PROJECT NO.	SHEET NO.

PROJECT _____
 SUBJECT _____
 BY _____ DATE ____ / ____ / ____

LAG SCREWS

Table 12K LAG SCREWS: Reference Lateral Design Values, Z, for Single Shear (two member) Connections^{1,2,3,4}

for sawn lumber or SCL with ASTM A653, Grade 33 steel side plate (for $t_s < 1/4"$) or ASTM A 36 steel side plate (for $t_s = 1/4"$)
 (tabulated lateral design values are calculated based on an assumed length of lag screw penetration, p, into the main member equal to 8D)



Side Member Thickness t_s in.	Lag Screw Diameter D in.	G=0.67 Red Oak		G=0.55 Mixed Maple Southern Pine		G=0.5 Douglas Fir/Larch		G=0.49 Douglas Fir/Larch (N)		G=0.46 Douglas Fir(S) Hem-Fir(N)		G=0.43 Hem-Fir		G=0.42 Spruce-Pine-Fir		G=0.37 Redwood (open grain)		G=0.36 Eastern Softwoods Spruce-Pine-Fir(S) Western Cedars Western Woods		G=0.35 Northern Species	
		$Z_{ }$ lbs.	Z_{\perp} lbs.	$Z_{ }$ lbs.	Z_{\perp} lbs.	$Z_{ }$ lbs.	Z_{\perp} lbs.	$Z_{ }$ lbs.	Z_{\perp} lbs.	$Z_{ }$ lbs.	Z_{\perp} lbs.	$Z_{ }$ lbs.	Z_{\perp} lbs.	$Z_{ }$ lbs.	Z_{\perp} lbs.	$Z_{ }$ lbs.	Z_{\perp} lbs.	$Z_{ }$ lbs.	Z_{\perp} lbs.	$Z_{ }$ lbs.	Z_{\perp} lbs.
0.075 (14 gage)	1/4	170	130	160	120	150	110	150	110	150	100	140	100	140	100	130	90	130	90	130	90
	5/16	220	160	200	140	190	130	190	130	190	130	180	120	180	120	170	110	170	110	160	100
	3/8	220	160	200	140	200	130	190	130	190	120	180	120	180	120	170	110	170	100	170	100
0.105 (12 gage)	1/4	180	140	170	130	160	120	160	120	160	110	150	110	150	110	140	100	140	100	140	90
	5/16	230	170	210	150	200	140	200	140	190	130	190	130	190	120	180	110	170	110	170	110
	3/8	230	160	210	140	200	140	200	130	200	130	190	120	190	120	180	110	180	110	170	110
0.120 (11 gage)	1/4	190	150	180	130	170	120	170	120	160	120	160	110	160	110	150	100	150	100	140	100
	5/16	230	170	210	150	210	140	200	140	200	140	190	130	190	130	180	120	180	120	180	110
	3/8	240	170	220	150	210	140	210	140	200	130	200	130	190	120	180	110	180	110	180	110
0.134 (10 gage)	1/4	200	150	180	140	180	130	170	120	160	120	160	120	160	110	150	110	150	100	150	100
	5/16	240	180	220	160	210	150	210	140	200	140	200	130	200	130	190	120	180	120	180	120
	3/8	240	170	220	150	220	140	210	140	210	140	200	130	200	130	190	120	190	120	180	110
0.179 (7 gage)	1/4	220	170	210	150	200	150	200	140	190	140	190	130	190	130	180	120	170	120	170	120
	5/16	260	190	240	170	230	160	230	160	230	150	220	150	220	150	210	130	200	130	200	130
	3/8	270	190	250	170	240	160	240	160	230	150	220	140	220	140	210	130	210	130	200	130
0.239 (3 gage)	1/4	240	180	220	160	210	150	210	150	200	140	190	140	190	130	180	120	180	120	180	120
	5/16	300	220	280	190	270	180	260	180	260	170	250	160	250	160	230	150	230	150	230	140
	3/8	310	220	280	190	270	180	260	170	250	160	250	160	250	160	240	140	230	140	230	140
	7/16	420	290	390	260	380	240	370	240	360	230	350	220	350	220	330	200	330	200	320	190
	1/2	510	340	470	300	460	290	450	280	440	270	430	260	420	260	400	240	400	230	390	230
	5/8	770	490	710	430	680	400	660	380	640	370	630	360	600	330	590	330	580	320	580	320
	3/4	1110	670	1020	590	980	560	970	550	950	530	920	500	910	500	860	450	850	450	840	440
	7/8	1510	880	1390	780	1330	730	1320	710	1280	690	1250	650	1230	650	1170	590	1160	590	1140	570
	1	1940	1100	1780	960	1710	910	1700	890	1650	860	1600	820	1590	810	1500	740	1480	730	1460	710
	1/4	1/4	240	180	220	160	210	150	210	150	200	140	200	140	190	130	180	120	180	120	180
5/16		310	220	280	200	270	180	270	180	260	170	250	170	250	160	230	150	230	150	230	140
3/8		320	220	290	190	280	180	270	180	270	170	260	160	250	160	240	150	240	140	230	140
7/16		480	320	440	280	420	270	420	260	410	250	390	240	390	230	370	220	360	210	360	210
1/2		580	390	540	340	520	320	510	320	500	310	480	290	480	290	460	270	450	260	440	260
5/8		850	530	780	470	750	440	740	440	720	420	700	400	690	400	660	370	650	360	640	350
3/4		1200	730	1100	640	1060	600	1050	590	1020	570	990	540	980	530	930	490	920	480	900	470
7/8		1600	930	1470	820	1410	770	1400	750	1360	720	1320	690	1310	680	1240	630	1220	620	1200	600
1		2040	1150	1870	1000	1800	950	1780	930	1730	900	1680	850	1660	840	1570	770	1550	760	1530	740

1. Tabulated lateral design values, Z, shall be multiplied by all applicable adjustment factors (see Table 11.3.1).
2. Tabulated lateral design values, Z, are for "reduced body diameter" lag screws (see Appendix Table L.2) inserted in side grain with screw axis perpendicular to wood fibers; screw penetration, p, into the main member equal to 8D; dowel bearing strengths, F_{\perp} , of 61,850 psi for ASTM A653, Grade 33 steel and 87,000 psi for ASTM A36 steel and screw bending yield strengths, F_{yb} , of 70,000 psi for D = 1/4", 60,000 psi for D = 5/16", and 45,000 psi for D \geq 3/8".
3. Where the lag screw penetration, p, is less than 8D but not less than 4D, tabulated lateral design values, Z, shall be multiplied by p/8D or lateral design values shall be calculated using the provisions of 12.3 for the reduced penetration.
4. The length of lag screw penetration, p, not including the length of the tapered tip, E (see Appendix Table L.2), of the lag screw into the main member shall not be less than 4D. See 12.1.4.6 for minimum length of penetration, p_{min} .

SDS connection of steel plate to wood, assuming HF, 100 lbs per 1/4" DIA SDS un-factored, without group action reduction, pending application/spacing.

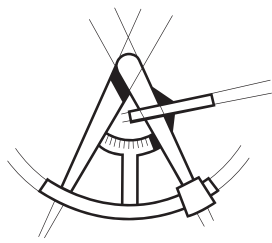

LONGITUDE
ONE TWENTY^o
 ENGINEERING & DESIGN

PROJECT NO.	SHEET NO.

PROJECT _____
 SUBJECT _____
 BY _____ DATE ____ / ____ / ____

Table 12L WOOD SCREWS: Reference Lateral Design Values, Z, for Single Shear (two member) Connections^{1,2,3}

for sawn lumber or SCL with both members of identical specific gravity (tabulated lateral design values are calculated based on an assumed length of wood screw penetration, p, into the main member equal to 10D)



Side Member Thickness <i>t_s</i> in.	Wood Screw Diameter <i>D</i> in.	Wood Screw Number	G=0.67 Red Oak	G=0.55 Mixed Maple Southern Pine	G=0.5 Douglas Fir-Larch	G=0.49 Douglas Fir-Larch(N)	G=0.46 Douglas Fir(S) Hem-Fir(N)	G=0.43 Hem-Fir	G=0.42 Spruce-Pine-Fir	G=0.37 Redwood (open grain)	G=0.36 Eastern Softwoods Spruce-Pine-Fir(S) Western Cedars Western Woods	G=0.35 Northern Species
			lbs.	lbs.	lbs.	lbs.	lbs.	lbs.	lbs.	lbs.	lbs.	lbs.
1/2	0.138	6	88	67	59	57	53	49	47	41	40	38
	0.151	7	96	74	65	63	59	54	52	45	44	42
	0.164	8	107	82	73	71	66	61	59	51	50	48
	0.177	9	121	94	83	81	76	70	68	59	58	56
	0.190	10	130	101	90	87	82	75	73	64	63	60
	0.216	12	156	123	110	107	100	93	91	79	78	75
5/8	0.242	14	168	133	120	117	110	102	99	87	86	83
	0.138	6	94	76	66	64	59	53	52	44	43	41
	0.151	7	104	83	72	70	64	58	56	48	47	45
	0.164	8	120	92	80	77	72	65	63	54	53	51
	0.177	9	136	103	91	88	81	74	72	62	61	58
	0.190	10	146	111	97	94	88	80	78	67	65	63
3/4	0.216	12	173	133	117	114	106	97	95	82	80	77
	0.242	14	184	142	126	123	115	106	103	89	87	84
	0.138	6	94	79	72	71	65	58	57	47	46	44
	0.151	7	104	87	80	77	71	64	62	52	50	48
	0.164	8	120	101	88	85	78	71	69	58	56	54
	0.177	9	142	114	99	96	88	80	78	66	64	61
1-1/4	0.190	10	153	122	107	103	95	86	83	71	69	66
	0.216	12	184	142	126	123	115	106	103	89	87	84
	0.242	14	213	178	157	152	139	126	122	102	100	95
	0.138	6	94	79	72	71	67	63	61	55	54	52
	0.151	7	104	87	80	78	74	69	68	60	59	57
	0.164	8	120	101	92	90	85	80	78	70	68	66
1-1/2	0.177	9	142	118	108	106	100	94	92	82	80	78
	0.190	10	153	128	117	114	108	101	99	88	87	84
	0.216	12	193	161	147	144	137	128	125	108	105	100
	0.242	14	213	178	163	159	151	141	138	115	111	106
	0.138	6	94	79	72	71	67	63	61	55	54	52
	0.151	7	104	87	80	78	74	69	68	60	59	57
1-3/4	0.164	8	120	101	92	90	85	80	78	70	68	66
	0.177	9	142	118	108	106	100	94	92	82	80	78
	0.190	10	153	128	117	114	108	101	99	88	87	84
	0.216	12	193	161	147	144	137	128	125	111	109	106
	0.242	14	213	178	163	159	151	141	138	123	120	117
	0.138	6	94	79	72	71	67	63	61	55	54	52
1-3/4	0.151	7	104	87	80	78	74	69	68	60	59	57
	0.164	8	120	101	92	90	85	80	78	70	68	66
	0.177	9	142	118	108	106	100	94	92	82	80	78
	0.190	10	153	128	117	114	108	101	99	88	87	84
	0.216	12	193	161	147	144	137	128	125	111	109	106
	0.242	14	213	178	163	159	151	141	138	123	120	117

Exterior: Typical Ledger connection w/ SDS, un-factored since typical Deck loading application with duration = 1. Minimum (3) SDSW screws into RIM @ 12" o.c stud. Assuming worst case with 12' deck framing with connections into RIM @ 12" o.c w/ 60 psf LL and 10 psf DL - loading on each connection, staggered, (and ignoring capacity of typical nailing of rim). Connection is 6' x 72 psf x 1.00 = 432# versus capacity into DF/Engineered lumber (LSL) - 489#, ok.

Interior: Typical Ledger connection w/ SDS, un-factored since typical floor loading application with duration = 1. Minimum (3) SDSW screws into studs/rim @ 16" o.c stud. Assuming worst case with 14' floor framing with connections into RIM @ 16" o.c w/ 40 psf LL and 12 psf DL - loading on each connection, staggered, (and ignoring capacity of typical nailing of rim). Connection is 7' x 52 psf x 1.00 = 364# versus capacity into HF lumber (SS) - 423#, ok.

WOOD SCREWS

DOWEL-TYPE FASTENERS

12

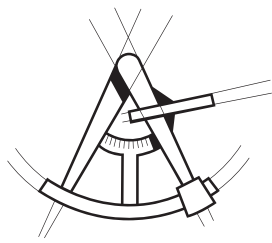

PROJECT _____
SUBJECT _____
BY _____ DATE ____ / ____ / ____

Table 12.2A Lag Screw Reference Withdrawal Design Values, W¹

Tabulated withdrawal design values (W) are in pounds per inch of thread penetration into side grain of wood member. Length of thread penetration in main member shall not include the length of the tapered tip (see 12.2.1.1).

Specific Gravity, G ²	Lag Screw Diameter, D										
	1/4"	5/16"	3/8"	7/16"	1/2"	5/8"	3/4"	7/8"	1"	1-1/8"	1-1/4"
0.73	397	469	538	604	668	789	905	1016	1123	1226	1327
0.71	381	450	516	579	640	757	868	974	1077	1176	1273
0.68	357	422	484	543	600	709	813	913	1009	1103	1193
0.67	349	413	473	531	587	694	796	893	987	1078	1167
0.58	281	332	381	428	473	559	641	719	795	869	940
0.55	260	307	352	395	437	516	592	664	734	802	868
0.51	232	274	314	353	390	461	528	593	656	716	775
0.50	225	266	305	342	378	447	513	576	636	695	752
0.49	218	258	296	332	367	434	498	559	617	674	730
0.47	205	242	278	312	345	408	467	525	580	634	686
0.46	199	235	269	302	334	395	453	508	562	613	664
0.44	186	220	252	283	312	369	423	475	525	574	621
0.43	179	212	243	273	302	357	409	459	508	554	600
0.42	173	205	235	264	291	344	395	443	490	535	579
0.41	167	198	226	254	281	332	381	428	473	516	559
0.40	161	190	218	245	271	320	367	412	455	497	538
0.39	155	183	210	236	261	308	353	397	438	479	518
0.38	149	176	202	227	251	296	340	381	422	461	498
0.37	143	169	194	218	241	285	326	367	405	443	479
0.36	137	163	186	209	231	273	313	352	389	425	460
0.35	132	156	179	200	222	262	300	337	373	407	441
0.31	110	130	149	167	185	218	250	281	311	339	367

1. Tabulated withdrawal design values, W, for lag screw connections shall be multiplied by all applicable adjustment factors (see Table 11.3.1).
2. Specific gravity, G_s, shall be determined in accordance with Table 12.3.3A.

12.2.3.2 For calculation of the fastener reference withdrawal design value in pounds, the unit reference withdrawal design value in lbs/in. of fastener penetration from 12.2.3.1 shall be multiplied by the length of fastener penetration, p_s, into the wood member.

12.2.3.3 The reference withdrawal design value, in lbs/in. of penetration, for a single post-frame ring shank nail driven in the side grain of the main member, with the nail axis perpendicular to the wood fibers, shall be determined from Table 12.2D or Equation 12.2-4, within the range of specific gravities and nail diameters given in Table 12.2D. Reference withdrawal design values, W, shall be multiplied by all applicable adjustment factors (see Table 11.3.1) to obtain adjusted withdrawal design values, W¹.

$$W = 1800 G^2 D \quad (12.2-4)$$

Ledger withdrawal capacity - assuming minimum 1 1/2" embed (tip discounted) into SS/HF material = 179# x 1.5 x 3 = 805# per 16" of ledger connection (maximum utilized)

12.2.3.4 For calculation of the fastener reference withdrawal design value in pounds, the unit reference withdrawal design value in lbs/in. of ring shank penetration from 12.2.3.3 shall be multiplied by the length of ring shank penetration, p_s, into the wood member.

12.2.3.5 Nails and spikes shall not be loaded in withdrawal from end grain of wood (C_{eg}=0.0).

12.2.3.6 Nails, and spikes shall not be loaded in withdrawal from end-grain of laminations in cross-laminated timber (C_{eg}=0.0).

12.2.4 Drift Bolts and Drift Pins

Reference withdrawal design values, W, for connections using drift bolt and drift pin connections shall be determined in accordance with 11.1.1.3.

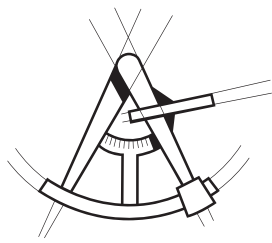

LONGITUDE
ONE TWENTY°
 ENGINEERING & DESIGN

PROJECT NO.	SHEET NO.

PROJECT _____
 SUBJECT _____
 BY _____ DATE ____ / ____ / ____

WOOD SCREWS

Table 12M WOOD SCREWS: Reference Lateral Design Values, Z, for Single Shear (two member) Connections^{1,2,3}

for sawn lumber or SCL with ASTM 653, Grade 33 steel side plate
 (tabulated lateral design values are calculated based on an assumed length of wood screw penetration, p, into the main member equal to 10D)

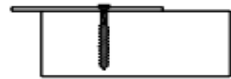

Side Member Thickness in.	Wood Screw Diameter D in.	Wood Screw Number	G=0.67	G=0.55	G=0.5	G=0.49	G=0.46	G=0.43	G=0.42	G=0.37	G=0.36	G=0.35
			Red Oak	Mixed Maple Southern Pine	Douglas Fir-Larch	Douglas Fir-Larch(N)	Douglas Fir(S) Hem-Fir(N)	Hem-Fir	Spruce-Pine-Fir	Redwood (open grain)	Eastern Softwoods Spruce-Pine-Fir(S) Western Cedars Western Woods	Northern Species
0.036 (20 gage)	0.138	6	89	76	70	69	66	62	60	54	53	52
	0.151	7	99	84	78	76	72	68	67	60	59	57
	0.164	8	113	97	89	87	83	78	77	69	67	66
0.048 (18 gage)	0.138	6	90	77	71	70	67	63	61	55	54	53
	0.151	7	100	85	79	77	74	69	68	61	60	58
	0.164	8	114	98	90	89	84	79	78	70	69	67
0.060 (16 gage)	0.138	6	92	79	73	72	68	64	63	57	56	54
	0.151	7	101	87	81	79	75	71	70	63	61	60
	0.164	8	116	100	92	90	86	81	79	71	70	68
	0.177	9	136	116	107	105	100	94	93	83	82	79
	0.190	10	146	125	116	114	108	102	100	90	88	86
0.075 (14 gage)	0.138	6	95	82	76	75	71	67	66	59	58	57
	0.151	7	105	90	84	82	78	74	72	65	64	62
	0.164	8	119	103	95	93	89	84	82	74	73	71
	0.177	9	139	119	110	108	103	97	95	86	84	82
	0.190	10	150	128	119	117	111	105	103	92	91	88
0.105 (12 gage)	0.216	12	186	159	147	145	138	130	127	114	112	109
	0.242	14	204	175	162	158	151	142	139	125	123	120
	0.138	6	104	90	84	82	79	74	73	66	65	63
	0.151	7	114	99	92	90	86	81	80	72	71	69
	0.164	8	129	111	103	102	97	92	90	81	80	77
0.120 (11 gage)	0.177	9	148	128	119	116	111	105	103	93	91	89
	0.190	10	160	138	128	125	120	113	111	100	98	96
	0.216	12	196	168	156	153	146	138	135	122	120	116
	0.242	14	213	183	170	167	159	150	147	132	130	126
	0.138	6	110	95	89	87	83	79	77	70	68	67
0.134 (10 gage)	0.151	7	120	104	97	95	91	86	84	76	75	73
	0.164	8	135	117	109	107	102	96	94	85	84	82
	0.177	9	154	133	124	121	116	110	107	97	95	93
	0.190	10	166	144	133	131	125	118	116	104	103	100
	0.216	12	202	174	162	159	152	143	140	126	124	121
0.179 (7 gage)	0.242	14	219	189	175	172	164	155	152	137	134	131
	0.138	6	116	100	93	92	88	83	81	73	72	70
	0.151	7	126	110	102	100	96	91	89	80	79	77
	0.164	8	141	122	114	112	107	101	99	89	88	86
	0.177	9	160	139	129	127	121	114	112	101	100	97
0.239 (3 gage)	0.190	10	173	149	139	136	130	123	121	109	107	104
	0.216	12	209	180	167	164	157	148	145	131	129	126
	0.242	14	226	195	181	177	169	160	157	141	139	135
	0.138	6	126	107	99	97	92	86	84	76	74	72
	0.151	7	139	118	109	107	102	95	93	84	82	80
0.179 (7 gage)	0.164	8	160	136	126	123	117	110	108	96	95	92
	0.177	9	184	160	148	145	138	129	127	113	111	108
	0.190	10	198	172	159	156	149	140	137	122	120	117
	0.216	12	234	203	189	186	178	168	165	149	146	143
	0.242	14	251	217	202	198	190	179	176	159	156	152
0.239 (3 gage)	0.138	6	126	107	99	97	92	86	84	76	74	72
	0.151	7	139	118	109	107	102	95	93	84	82	80
	0.164	8	160	136	126	123	117	110	108	96	95	92
	0.177	9	188	160	148	145	138	129	127	113	111	108
	0.190	10	204	173	159	156	149	140	137	122	120	117
0.239 (3 gage)	0.216	12	256	218	201	197	187	176	172	154	151	147
	0.242	14	283	241	222	217	207	194	190	170	167	162

1. Tabulated lateral design values, Z, shall be multiplied by all applicable adjustment factors (see Table 11.3.1).
2. Tabulated lateral design values, Z, are for rolled thread wood screws (see Appendix L) inserted in side grain with screw axis perpendicular to wood fibers; screw penetration, p, into the main member equal to 10D; dowel bearing strength, F_{db}, of 61,850 psi for ASTM A653, Grade 33 steel and screw bending yield strengths, F_b, of 100,000 psi for 0.099" ≤ D ≤ 0.142", 90,000 psi for 0.142" < D ≤ 0.177", 80,000 psi for 0.177" < D ≤ 0.236", 70,000 psi for 0.236" < D ≤ 0.273".
3. Where the wood screw penetration, p, is less than 10D but not less than 6D, tabulated lateral design values, Z, shall be multiplied by p/10D or lateral design values shall be calculated using the provisions of 12.3 for the reduced penetration.

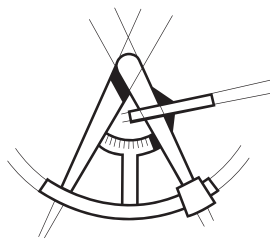

LONGITUDE
ONE TWENTY[°]
 ENGINEERING & DESIGN

PROJECT NO.	SHEET NO.

PROJECT _____
 SUBJECT _____
 BY _____ DATE ____ / ____ / ____

Table 12P COMMON, BOX, or SINKER STEEL WIRE NAILS: Reference Lateral Design Values, Z, for Single Shear (two member) Connections^{1,2,3}

for sawn lumber or SCL with ASTM 653, Grade 33 steel side plate
 (tabulated lateral design values are calculated based on an assumed length of nail penetration, p, into the main member equal to 10D)



NAILS

Side Member Thickness t_1 in.	Nail Diameter D in.	Common Wire Nail		G=0.67 Red Oak	G=0.55 Mixed Maple Southern Pine	G=0.5 Douglas Fir-Larch	G=0.49 Douglas Fir-Larch (N)	G=0.46 Douglas Fir(S) Hem-Fir(N)	G=0.43 Hem-Fir	G=0.42 Spruce-Pine-Fir	G=0.37 Redwood (open grain)	G=0.36 Eastern Softwoods Spruce-Pine-Fir(S) Western Cedars Western Woods	G=0.35 Northern Species
		Box Nail	Sinker Nail										
0.120 (11 gage)	0.099	6d	7d	90	78	72	71	68	64	63	57	56	53
		6d	8d	110	95	89	87	83	79	77	70	68	66
	0.113	10d	10d	121	105	97	96	91	86	85	76	75	73
		10d	10d	134	116	108	106	101	96	94	85	83	81
	0.128	8d	8d	140	121	112	110	105	99	97	88	86	84
		16d	12d	147	127	118	116	110	104	102	92	91	88
	0.148	10d	20d	165	143	133	130	124	117	115	104	102	99
		16d	40d	193	166	154	152	145	137	134	121	119	115
	0.177	20d	20d	218	188	174	171	163	154	151	136	134	130
		20d	30d	226	195	181	177	169	159	156	141	138	135
	0.207	30d	40d	244	210	194	191	182	172	168	151	149	145
		40d	40d	265	228	211	207	198	186	183	164	161	157
	0.225	40d	40d	272	234	217	213	203	191	187	169	166	161
		50d	60d	272	234	217	213	203	191	187	169	166	161
0.134 (10 gage)	0.099	6d	7d	95	82	76	74	71	66	65	58	56	54
		6d	8d	116	100	93	92	88	83	81	73	72	69
	0.113	10d	10d	127	110	102	100	96	91	89	80	79	76
		10d	10d	140	122	113	111	106	100	98	89	87	85
	0.128	8d	8d	146	126	117	115	110	104	102	92	90	88
		16d	12d	153	132	123	121	115	109	107	96	95	92
	0.148	10d	20d	172	148	138	135	129	122	120	108	106	104
		16d	40d	199	172	160	157	150	142	139	125	123	120
	0.177	20d	20d	224	194	180	176	169	159	156	141	138	135
		20d	30d	232	200	186	182	174	164	161	145	143	139
	0.207	30d	40d	249	215	199	196	187	176	173	156	153	149
		40d	40d	270	233	216	212	202	191	187	168	165	161
	0.225	40d	40d	277	239	221	217	207	195	192	173	170	165
		50d	60d	277	239	221	217	207	195	192	173	170	165
0.179 (7 gage)	0.099	6d	7d	97	82	76	74	71	66	65	58	56	54
		6d	8d	126	107	99	97	92	86	84	76	74	70
	0.113	10d	10d	142	121	111	109	104	97	95	85	83	79
		10d	10d	161	137	126	124	118	111	108	97	94	90
	0.128	8d	8d	168	144	132	130	123	116	114	102	99	94
		16d	12d	175	152	141	138	131	123	121	108	105	100
	0.148	10d	20d	195	170	158	155	148	140	137	123	121	117
		16d	40d	224	194	180	177	169	160	157	142	140	136
	0.177	20d	20d	249	215	200	197	188	178	174	157	155	151
		20d	30d	256	222	206	203	194	183	179	162	159	155
	0.207	30d	40d	272	236	219	215	205	194	190	172	169	164
		40d	40d	292	252	234	230	220	207	203	184	180	176
	0.225	40d	40d	299	258	240	235	225	212	208	188	185	180
		50d	60d	299	258	240	235	225	212	208	188	185	180
0.239 (3 gage)	0.099	6d	7d	97	82	76	74	71	66	65	58	56	54
		6d	8d	126	107	99	97	92	86	84	76	74	70
	0.113	10d	10d	142	121	111	109	104	97	95	85	83	79
		10d	10d	161	137	126	124	118	111	108	97	94	90
	0.128	8d	8d	169	144	132	130	123	116	114	102	99	94
		16d	12d	180	153	141	138	131	123	121	108	105	100
	0.148	10d	20d	205	174	160	157	149	140	137	123	121	117
		16d	40d	245	209	192	188	179	168	165	147	145	140
	0.177	20d	20d	284	241	222	218	207	195	191	170	167	162
		20d	30d	295	251	231	227	216	202	198	177	174	169
	0.207	30d	40d	310	270	251	246	236	222	217	194	191	185
		40d	40d	328	285	265	260	249	235	231	209	205	200
	0.225	40d	40d	336	291	271	266	254	240	236	213	210	204
		50d	60d	336	291	271	266	254	240	236	213	210	204

DOVEL-TYPE FASTENERS

12

1. Tabulated lateral design values, Z, shall be multiplied by all applicable adjustment factors (see Table 11.3.1).
2. Tabulated lateral design values, Z, are for common, box, or sinker steel wire nails (see Appendix Table L4) inserted in side grain with nail axis perpendicular to wood fibers; nail penetration, p, into the main member equal to 10D; dowel bearing strength, F_{db} , of 61,850 psi for ASTM A653, Grade 33 steel and nail bending yield strengths, F_{yb} , of 100,000 psi for 0.099" $\leq D \leq 0.142$ ", 90,000 psi for 0.142" $< D \leq 0.177$ ", 80,000 psi for 0.177" $< D \leq 0.236$ ", 70,000 psi for 0.236" $< D \leq 0.273$ ".
3. Where the nail or spike penetration, p, is less than 10D but not less than 6D, tabulated lateral design values, Z, shall be multiplied by p/10D or lateral design values shall be calculated using the provisions of 12.3 for the reduced penetration.

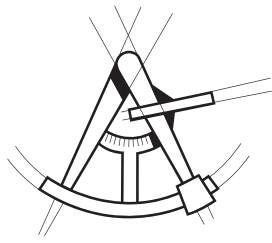

LONGITUDE
ONE TWENTY^o
 ENGINEERING & DESIGN

PROJECT NO.	SHEET NO.

PROJECT _____

SUBJECT _____

BY _____ DATE ____ / ____ / ____

Table 11.3.6A Group Action Factors, C_g , for Bolt or Lag Screw Connections with Wood Side Members²

For D = 1", s = 4", E = 1,400,000 psi

A_s/A_m ¹	A_s ¹ in. ²	Number of fasteners in a row										
		2	3	4	5	6	7	8	9	10	11	12
0.5	5	0.98	0.92	0.84	0.75	0.68	0.61	0.55	0.50	0.45	0.41	0.38
	12	0.99	0.96	0.92	0.87	0.81	0.76	0.70	0.65	0.61	0.57	0.53
	20	0.99	0.98	0.95	0.91	0.87	0.83	0.78	0.74	0.70	0.66	0.62
	28	1.00	0.98	0.96	0.93	0.90	0.87	0.83	0.79	0.76	0.72	0.69
	40	1.00	0.99	0.97	0.95	0.93	0.90	0.87	0.84	0.81	0.78	0.75
	64	1.00	0.99	0.98	0.97	0.95	0.93	0.91	0.89	0.87	0.84	0.82
1	5	1.00	0.97	0.91	0.85	0.78	0.71	0.64	0.59	0.54	0.49	0.45
	12	1.00	0.99	0.96	0.93	0.88	0.84	0.79	0.74	0.70	0.65	0.61
	20	1.00	0.99	0.98	0.95	0.92	0.89	0.86	0.82	0.78	0.75	0.71
	28	1.00	0.99	0.98	0.97	0.94	0.92	0.89	0.86	0.83	0.80	0.77
	40	1.00	1.00	0.99	0.98	0.96	0.94	0.92	0.90	0.87	0.85	0.82
	64	1.00	1.00	0.99	0.98	0.97	0.96	0.95	0.93	0.91	0.90	0.88

- Where $A_s/A_m > 1.0$, use A_m/A_s and use A_m instead of A_s .
- Tabulated group action factors (C_g) are conservative for $D < 1"$, $s < 4"$, or $E > 1,400,000$ psi.

Table 11.3.6B Group Action Factors, C_g , for 4" Split Ring or Shear Plate Connectors with Wood Side Members²

s = 9", E = 1,400,000 psi

A_s/A_m ¹	A_s ¹ in. ²	Number of fasteners in a row										
		2	3	4	5	6	7	8	9	10	11	12
0.5	5	0.90	0.73	0.59	0.48	0.41	0.35	0.31	0.27	0.25	0.22	0.20
	12	0.95	0.83	0.71	0.60	0.52	0.45	0.40	0.36	0.32	0.29	0.27
	20	0.97	0.88	0.78	0.69	0.60	0.53	0.47	0.43	0.39	0.35	0.32
	28	0.97	0.91	0.82	0.74	0.66	0.59	0.53	0.48	0.44	0.40	0.37
	40	0.98	0.93	0.86	0.79	0.72	0.65	0.59	0.54	0.49	0.45	0.42
	64	0.99	0.95	0.91	0.85	0.79	0.73	0.67	0.62	0.58	0.54	0.50
1	5	1.00	0.87	0.72	0.59	0.50	0.43	0.38	0.34	0.30	0.28	0.25
	12	1.00	0.93	0.83	0.72	0.63	0.55	0.48	0.43	0.39	0.36	0.33
	20	1.00	0.95	0.88	0.79	0.71	0.63	0.57	0.51	0.46	0.42	0.39
	28	1.00	0.97	0.91	0.83	0.76	0.69	0.62	0.57	0.52	0.47	0.44
	40	1.00	0.98	0.93	0.87	0.81	0.75	0.69	0.63	0.58	0.54	0.50
	64	1.00	0.98	0.95	0.91	0.87	0.82	0.77	0.72	0.67	0.62	0.58

- Where $A_s/A_m > 1.0$, use A_m/A_s and use A_m instead of A_s .
- Tabulated group action factors (C_g) are conservative for 2-1/2" split ring connectors, 2-5/8" shear plate connectors, $s < 9"$, or $E > 1,400,000$ psi.

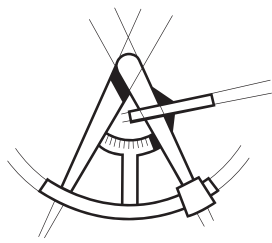

LONGITUDE

ONE TWENTY°

ENGINEERING & DESIGN

PROJECT NO.	SHEET NO.

PROJECT _____

SUBJECT _____

BY _____ DATE ____ / ____ / ____

Table 11.3.6C Group Action Factors, C_g , for Bolt or Lag Screw Connections with Steel Side Plates¹

For $D = 1"$, $s = 4"$, $E_{wood} = 1,400,000$ psi, $E_{steel} = 30,000,000$ psi

A_m/A_s	A_m in. ²	Number of fasteners in a row										
		2	3	4	5	6	7	8	9	10	11	12
12	5	0.97	0.89	0.80	0.70	0.62	0.55	0.49	0.44	0.40	0.37	0.34
	8	0.98	0.93	0.85	0.77	0.70	0.63	0.57	0.52	0.47	0.43	0.40
	16	0.99	0.96	0.92	0.86	0.80	0.75	0.69	0.64	0.60	0.55	0.52
	24	0.99	0.97	0.94	0.90	0.85	0.81	0.76	0.71	0.67	0.63	0.59
	40	1.00	0.98	0.96	0.94	0.90	0.87	0.83	0.79	0.76	0.72	0.69
	64	1.00	0.99	0.98	0.96	0.94	0.91	0.88	0.86	0.83	0.80	0.77
	120	1.00	0.99	0.99	0.98	0.96	0.95	0.93	0.91	0.90	0.87	0.85
	200	1.00	1.00	0.99	0.99	0.98	0.97	0.96	0.95	0.93	0.92	0.90
18	5	0.99	0.93	0.85	0.76	0.68	0.61	0.54	0.49	0.44	0.41	0.37
	8	0.99	0.95	0.90	0.83	0.75	0.69	0.62	0.57	0.52	0.48	0.44
	16	1.00	0.98	0.94	0.90	0.85	0.79	0.74	0.69	0.65	0.60	0.56
	24	1.00	0.98	0.96	0.93	0.89	0.85	0.80	0.76	0.72	0.68	0.64
	40	1.00	0.99	0.97	0.95	0.93	0.90	0.87	0.83	0.80	0.77	0.73
	64	1.00	0.99	0.98	0.97	0.95	0.93	0.91	0.89	0.86	0.83	0.81
	120	1.00	1.00	0.99	0.98	0.97	0.96	0.95	0.93	0.92	0.90	0.88
	200	1.00	1.00	0.99	0.99	0.98	0.98	0.97	0.96	0.95	0.94	0.92
24	40	1.00	0.99	0.97	0.95	0.93	0.89	0.86	0.83	0.79	0.76	0.72
	64	1.00	0.99	0.98	0.97	0.95	0.93	0.91	0.88	0.85	0.83	0.80
	120	1.00	1.00	0.99	0.98	0.97	0.96	0.95	0.93	0.91	0.90	0.88
	200	1.00	1.00	0.99	0.99	0.98	0.98	0.97	0.96	0.95	0.93	0.92
30	40	1.00	0.98	0.96	0.93	0.89	0.85	0.81	0.77	0.73	0.69	0.65
	64	1.00	0.99	0.97	0.95	0.93	0.90	0.87	0.83	0.80	0.77	0.73
	120	1.00	0.99	0.99	0.97	0.96	0.94	0.92	0.90	0.88	0.85	0.83
	200	1.00	1.00	0.99	0.98	0.97	0.96	0.95	0.94	0.92	0.90	0.89
35	40	0.99	0.97	0.94	0.91	0.86	0.82	0.77	0.73	0.68	0.64	0.60
	64	1.00	0.98	0.96	0.94	0.91	0.87	0.84	0.80	0.76	0.73	0.69
	120	1.00	0.99	0.98	0.97	0.95	0.92	0.90	0.88	0.85	0.82	0.79
	200	1.00	0.99	0.99	0.98	0.97	0.95	0.94	0.92	0.90	0.88	0.86
42	40	0.99	0.97	0.93	0.88	0.83	0.78	0.73	0.68	0.63	0.59	0.55
	64	0.99	0.98	0.95	0.92	0.88	0.84	0.80	0.76	0.72	0.68	0.64
	120	1.00	0.99	0.97	0.95	0.93	0.90	0.88	0.85	0.81	0.78	0.75
	200	1.00	0.99	0.98	0.97	0.96	0.94	0.92	0.90	0.88	0.85	0.83
50	40	0.99	0.96	0.91	0.85	0.79	0.74	0.68	0.63	0.58	0.54	0.51
	64	0.99	0.97	0.94	0.90	0.85	0.81	0.76	0.72	0.67	0.63	0.59
	120	1.00	0.98	0.97	0.94	0.91	0.88	0.85	0.81	0.78	0.74	0.71
	200	1.00	0.99	0.98	0.96	0.95	0.92	0.90	0.87	0.85	0.82	0.79

1. Tabulated group action factors (C_g) are conservative for $D < 1"$ or $s < 4"$.

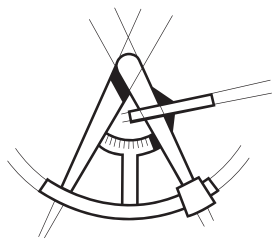

LONGITUDE
ONE TWENTY°
 ENGINEERING & DESIGN

PROJECT NO.	SHEET NO.

PROJECT _____

SUBJECT _____

BY _____ DATE ____ / ____ / ____

Table 11.3.6D Group Action Factors, C_g , for 4" Shear Plate Connectors with Steel Side Plates¹

$s = 9"$, $E_{wood} = 1,400,000$ psi, $E_{steel} = 30,000,000$ psi												
A_m/A_s	A_m in. ²	Number of fasteners in a row										
		2	3	4	5	6	7	8	9	10	11	12
12	5	0.91	0.75	0.60	0.50	0.42	0.36	0.31	0.28	0.25	0.23	0.21
	8	0.94	0.80	0.67	0.56	0.47	0.41	0.36	0.32	0.29	0.26	0.24
	16	0.96	0.87	0.76	0.66	0.58	0.51	0.45	0.40	0.37	0.33	0.31
	24	0.97	0.90	0.82	0.73	0.64	0.57	0.51	0.46	0.42	0.39	0.35
	40	0.98	0.94	0.87	0.80	0.73	0.66	0.60	0.55	0.50	0.46	0.43
	64	0.99	0.96	0.91	0.86	0.80	0.74	0.69	0.63	0.59	0.55	0.51
	120	0.99	0.98	0.95	0.91	0.87	0.83	0.79	0.74	0.70	0.66	0.63
	200	1.00	0.99	0.97	0.95	0.92	0.89	0.85	0.82	0.79	0.75	0.72
18	5	0.97	0.83	0.68	0.56	0.47	0.41	0.36	0.32	0.28	0.26	0.24
	8	0.98	0.87	0.74	0.62	0.53	0.46	0.40	0.36	0.32	0.30	0.27
	16	0.99	0.92	0.82	0.73	0.64	0.56	0.50	0.45	0.41	0.37	0.34
	24	0.99	0.94	0.87	0.78	0.70	0.63	0.57	0.51	0.47	0.43	0.39
	40	0.99	0.96	0.91	0.85	0.78	0.72	0.66	0.60	0.55	0.51	0.47
	64	1.00	0.97	0.94	0.89	0.84	0.79	0.74	0.69	0.64	0.60	0.56
	120	1.00	0.99	0.97	0.94	0.90	0.87	0.83	0.79	0.75	0.71	0.67
	200	1.00	0.99	0.98	0.96	0.94	0.91	0.89	0.86	0.82	0.79	0.76
24	40	1.00	0.96	0.91	0.84	0.77	0.71	0.65	0.59	0.54	0.50	0.46
	64	1.00	0.98	0.94	0.89	0.84	0.78	0.73	0.68	0.63	0.58	0.54
	120	1.00	0.99	0.96	0.94	0.90	0.86	0.82	0.78	0.74	0.70	0.66
	200	1.00	0.99	0.98	0.96	0.94	0.91	0.88	0.85	0.82	0.78	0.75
30	40	0.99	0.93	0.86	0.78	0.70	0.63	0.57	0.52	0.47	0.43	0.40
	64	0.99	0.96	0.90	0.84	0.78	0.71	0.66	0.60	0.56	0.51	0.48
	120	0.99	0.98	0.94	0.90	0.86	0.81	0.76	0.71	0.67	0.63	0.59
	200	1.00	0.98	0.96	0.94	0.91	0.87	0.83	0.79	0.76	0.72	0.68
35	40	0.98	0.91	0.83	0.74	0.66	0.59	0.53	0.48	0.43	0.40	0.36
	64	0.99	0.94	0.88	0.81	0.73	0.67	0.61	0.56	0.51	0.47	0.43
	120	0.99	0.97	0.93	0.88	0.82	0.77	0.72	0.67	0.62	0.58	0.54
	200	1.00	0.98	0.95	0.92	0.88	0.84	0.80	0.76	0.71	0.68	0.64
42	40	0.97	0.88	0.79	0.69	0.61	0.54	0.48	0.43	0.39	0.36	0.33
	64	0.98	0.92	0.84	0.76	0.69	0.62	0.56	0.51	0.46	0.42	0.39
	120	0.99	0.95	0.90	0.85	0.78	0.72	0.67	0.62	0.57	0.53	0.49
	200	0.99	0.97	0.94	0.90	0.85	0.80	0.76	0.71	0.67	0.62	0.59
50	40	0.95	0.86	0.75	0.65	0.56	0.49	0.44	0.39	0.35	0.32	0.30
	64	0.97	0.90	0.81	0.72	0.64	0.57	0.51	0.46	0.42	0.38	0.35
	120	0.98	0.94	0.88	0.81	0.74	0.68	0.62	0.57	0.52	0.48	0.45
	200	0.99	0.96	0.92	0.87	0.82	0.77	0.71	0.66	0.62	0.58	0.54

1. Tabulated group action factors (C_g) are conservative for 2-5/8" shear plate connectors or $s < 9"$.